

ರೈಲು ಮೂಲಸೌಲಭ್ಯ ಅಭಿವೃದ್ಧಿ ಕಂಪನಿ (ಕರ್ನಾಟಕ) ನಿಯಮಿತ

रेल इन्फ्रास्ट्रक्चर डेवलपमेंट कंपनी (कर्नाटक) लिमिटेड

**Rail Infrastructure Development Company (Karnataka) Limited
(K-RIDE)**

(A Joint Venture of Govt. of Karnataka and Ministry of Railways)

TENDER DOCUMENT FOR THE WORK OF

“Signaling Outdoor and indoor works with Distributed Electronic interlocking (EI) at Yesvantpur Jn. in connection with doubling of Yesvantpur-Channasandra section of Bangalore Division”

TENDER NO. K-RIDE/DL/SnT/13/2022, DATED: 07/09/2022

RAIL INFRASTRUCTURE DEVELOPMENT COMPANY (KARNATAKA) LIMITED

Samparka Soudha, 1st Floor,

Dr. Rajkumar Road,

Opposite Orion Mall,

Rajajinagar 1st Block, Bengaluru-560010

Tel +91-6364890850,

Email: gmst@kride.in, s.nageswararao.kride@ka.gov.in



TENDER DOCUMENT

(Through e-Tendering Mode)

Tender for the work of:

“Signaling Outdoor and indoor works with Distributed Electronic interlocking (EI) at Yesvantpur Jn. in connection with doubling of Yesvantpur-Channasandra section of Bangalore Division”.

TENDER NO:	K-RIDE/DL/SnT/13/2022, Date: 07.09.2022
TENDER DOCUMENT CAN BE DOWNLOADED FROM	Date: 07/09/2022
PERIOD OF SALE OF TENDER DOCUMENT	NA
LAST DATE FOR SALE OF TENDER DOCUMENT	NA
LAST DATE AND TIME FOR RECEIPT OF BIDS	Date: 10/10/2022 , IST 15:00 Hrs (Only electronic tender permitted.)
DATE AND TIME OF OPENING OF COVER ONE OF TENDER (TECHNICAL BID)	Date: 11/10/2022 , IST 15:30 Hrs
PLACE OF OPENING OF COVER ONE OF TENDER (TECHNICAL BID)	The opening of the Technical Bid shall take place at e- procurement portal of K-RIDE i.e., https://eproc.karnataka.gov.in
PLACE OF OPENING OF COVER TWO OF TENDERS (FINANCIAL BID)	The opening of the Financial Bid shall take place at e- procurement portal of K-RIDE i.e., https://eproc.karnataka.gov.in
DATE AND TIME OF OPENING OF COVER TWO OF TENDERS	Will be intimated to the Qualified Tenderers through Karnataka Public Procurement Portal.
ADDRESS FOR COMMUNICATION	GM/S&T K-RIDE (Rail Infrastructure Development Company (Karnataka) Limited) #8, 1 st Floor, Samparka Soudha, Dr. Rajkumar Road, Opposite Orion Mall Rajajinagar 1 st Block, BENGALURU Tel – 91-6364890850 EMail– gmst@kride.in , s.nageswararao.kride@ka.gov.in

CONTENTS

SECTION NO.	DESCRIPTION	PAGE NO.
1	INVITATION FOR TENDERS (IFT)	1-6
2	INSTRUCTIONS TO TENDERERS (ITT)	7-42
3	QUALIFICATION INFORMATION/ BIDDING FORMS	43-85
4	FORM OF TENDER, LETTER OF ACCEPTANCE, NOTICE TO PROCEED WITH THE WORK AND AGREEMENT FORM ETC.,	86-91
5	CONDITIONS OF CONTRACT (CC)	92-112
6	CONTRACT DATA	113-120
7	PARTICULAR CONDITIONS OF CONTRACT	121-236
8A	EMPLOYER'S REQUIREMENT – GENERAL INFORMATION AND SCOPE OF WORK	237-263
8B	TECHNICAL SPECIFICATIONS	264-344
8C	SAFETY, HEALTH AND ENVIRONMENT (SHE) MANUAL	345-350
9	BILL OF QUANTITIES	351-388
10	CONTRACT FORMS	389-404
11	DRAWINGS	---

SECTION: 1

NOTICE FOR INVITATION FOR TENDERS (IFT)

Rail Infrastructure Development Company (Karnataka) Limited

INVITATION FOR BIDS

(Through e-tendering mode)

Tender Notice No. **K RIDE/DL/SnT/13/2022**

Date: 07.09.2022

THE RAIL INFRASTRUCTURE DEVELOPMENT COMPANY (KARNATAKA) LIMITED (K-RIDE), having its Corporate office, at #8, 1st Floor, Samparka Soudha, Dr. Rajkumar Road, Opposite Orion Mall, Rajajinagar 1st Block, Bengaluru-560010, India, which is a Joint Venture of Government of Karnataka and Ministry of Railways invites Bids from eligible bidders, for the construction of works detailed in the table below under **Single stage: Two packet document system (Technical Bid and Financial Bid)**.

SL. NO.	NAME OF WORK	APPROX. VALUE OF WORK (IN ₹ RS)	TENDER SECURITY/ EMD	PERIOD OF COMPLETION
1	2	3	4	5
1	"Signaling Outdoor and indoor works with Distributed Electronic interlocking (EI) at Yesvantpur Jn. in connection with doubling of Yesvantpur-Channasandra section of Bangalore Division."	26,78,24,819/-	26,78,248/-	18 months

NOTE:

1. The Tenderers shall submit the tender through e - procurement portal. Tenderers should scan the registration copy; work done certificate and any other document and submit through online. More information can be had from website www.eproc.karnataka.gov.in
2. On the stipulated date of opening of Tenders, initially, only the Technical Bids are opened through Karnataka Public Procurement Portal. The Technical Bids shall be evaluated by the Employer in accordance with the stipulated Qualification and Evaluation criteria. No amendments or changes to the Technical Bids would be permitted after the opening of Technical Bids.

3. Tenderers who are qualified in the technical evaluation, their Price Bid shall be opened at a date and time advised by the Employer (K-RIDE) through e-tendering portal. The Price Bids are evaluated and the Contract is awarded to the Tenderer whose Tender has been determined to be the lowest evaluated substantially responsive tender.
4. Tenderers are advised to note the eligibility and minimum qualifying criteria specified in the Section 2: Instruction to Tenderers of the tender document.
5. Tenders must be accompanied by a Bid Security as per ITT 13.7 and Section 3: Qualification Information/Bidding Forms in any one of the forms as specified in the tender documents and shall have to be valid for 45 days beyond the validity of the tender. Any Tenders received without bid security, shall be summarily rejected.
6. Incomplete Tender submission will be considered non-responsive and such Tenders shall not be considered for further evaluation.
7. Tender Documents can be downloaded free of cost from Karnataka Public Procurement Portal i.e., <https://eproc.karnataka.gov.in> from **07/09/2022** and the Tenders must be submitted online via Karnataka Public Procurement Portal only.

Please note that drawings, if any, referred in the tender document, but not uploaded with the tender document, can be viewed in this office on any working day. The Tenderer can also have a copy of the same on payment of non-refundable cost of Rs. 5,000/- (Rupees Five Thousand only) by a e-Payment mode (credit card/debit card/net banking/UPI) in favour of **Rail Infrastructure Development Company (Karnataka) Limited**, Bangalore.

It will be the responsibility of the Tenderer who is submitting the Tender on downloaded Tender documents to check and see any Addendum/Corrigendum issued in this regard from the website from time to time and ensure submission of bid along with all Addendum/Corrigendum.

In case of any clarification the Tenderer can visit the Rail Infrastructure Development Company (Karnataka) limited Corporate Office Bengaluru at #8, 1st Floor, Samparka Soudha, Dr. Rajkumar Road, Opposite Orion Mall, Rajajinagar 1st Block, Bengaluru-560010. Tel. No.+91-6364890850.

8. **Validity of Tender:** Tenders shall remain valid for a period of **180** days after the Tender submission deadline date prescribed by the employer. A Tender valid for a shorter period shall be rejected by the employer as non-responsive.
9. In exceptional circumstances, the Employer may request Tenderers to extend the period of validity of their Tenders. The request and the responses shall be made in writing. If a bid security is requested in accordance with ITT 13, it shall also be extended up to the date mentioned in the letter of request for extension. A Tenderer may refuse the request without forfeiting its bid security. A Tenderer granting the request shall not be required or permitted to modify its Tender.
10. If, the office happens to be closed on the date of opening of Tender, the Tenders will be opened on next working day at the same time and venue.

11. A Pre- Bid meeting will be held on **16/09/2022** at 11:30 Hrs. IST at the office of K-RIDE, Bangalore to clarify the issues if any and to answer questions on any matter that may be raised at that stage as stated in Clause - 8 of ITT of the Tender document.

12. Other details can be seen in Tender documents.

13. REGISTRATION:

- a. Tenderers are required to enroll on the e-tendering Portal (<https://eproc.karnataka.gov.in>) with clicking on the link "Tenderers Registration" on the e-tender Portal by paying requisite registration fee as applicable.
- b. As part of the enrolment process, the Tenderers will be required to choose a unique user name and assign a password for their accounts.
- c. Tenderers are advised to register their valid email address and mobile numbers as part of the registration process. These would be used for any communication with the Tenderer.
- d. Upon enrolment, the Tenderers will be required to register their valid Digital Signature Certificate (Only Class III Certificates with signing + encryption key usage) issued by any Certifying Authority recognized by CCA India with their profile.
- e. Only one valid DSC should be registered by a Tenderer. Please note that the Tenderers are responsible to ensure that they do not lend their DSC"s to others which may lead to misuse.
- f. Tenderers then logs in to the site through the secured log-in by entering their user ID/password and the password of the DSC / e-Token.
- g. The scanned copies of all original documents should be uploaded on portal.
- h. For any query regarding e-procurement on the Karnataka Public Procurement Portal, contact helpdesk number **+91-8046010000, +91-8068948777, support@eprochelpdesk.com**

14. SEARCHING FOR PROPOSAL DOCUMENTS

Once the Tenderers have selected the proposals they are interested in, the Tenderers can pay nonrefundable processing fee as per the Karnataka Public Procurement Portal.

15. PRECAUTIONS FOR SUBMITTING / PREPARATION OF PROPOSALS THROUGH E TENDERING PORTAL

- a. Tenderer, in advance, should get ready the proposal documents to be submitted as indicated in the proposal document / schedule and generally, they can be in PDF /JPEG formats.
- b. Tenderer should log into the website well in advance for the submission of the proposal so that it gets uploaded well in time i.e., on or before the proposal submission time. Bidder will be responsible for any delay due to other issues.

- c. The Tenderer has to digitally sign and upload the required proposal documents one by one as indicated in the tendering document.
 - d. The server time (which is displayed on the consultant's dashboard) will be considered as the standard time for referencing the deadlines for submission of the proposals by the consultants, opening of proposals etc. The consultants should follow this time during proposal submission.
16. The Tenderer should furnish the Name of the individual / firm/ Company / Joint venture with address and telephone number with place of registration, year of incorporation etc.,
17. Tender by a joint venture of contractors is permitted subject to conditions indicated in tender document.
18. The application made by the firm / company / Joint Venture shall be signed by a person holding the power of attorney, in which case the Tenderer shall furnish a copy of power of attorney.

19. Employees Provident Fund Registration Certificate

The Contractor shall furnish EPF Registration Certificate before entering into agreement in the event of award of work to them after tender, subject to compliance with the following conditions:

- a) If the contractor is registered already with the EPF authorities, they should produce a copy of the EPF Registration Certificate.
 - b) If not registered with the EPF authorities, the Tenderer should produce an undertaking at the time of participating in the tender that he shall within 7 days of the close of every month submit a Statement to Engineer showing the recoveries of contribution in respect of Employees by or through him and shall also furnish such information as the Engineer is required to furnish under the provisions of the Scheme to the Commissioner EPF.
 - c) However, having given an undertaking to this effect if the Contractor does not furnish the information, the Employer will deduct the necessary amount from the amount due to the Contractor. Notwithstanding the above, the Contractor will be liable for any consequential penalty /damages levied by the EPF authorities.
20. The necessary certificates / documents in support fulfilling qualifying criteria stipulated separately shall be scanned and attached to e-procurement document. The original documents if required by the Employer shall be produced whenever asked by Employer on Technical Bid/ Financial Bid.
21. The intending Tenderers are advised to visit the site of work before attending the Pre- Bid meeting and also before submitting the Tenders.
22. The qualification criteria as indicated in bid document should be met by the intending Tenderers.
23. Tenderers shall not be under a declaration of ineligibility for corrupt and fraudulent practices issued by the Govt. of Karnataka, Govt of India and any PSUs thereof.

24. Pre-bid meeting will be held on **16/09/2022 at 11.30AM** in the office of K-RIDE Bangalore.
25. The conditional Tenders will not be accepted.
26. The Employer is not responsible for any delay in accessing Karnataka Public Procurement Portal.
27. The rates quoted by the Tenderer must be inclusive of all Taxes, Duties etc.,
28. The Employer reserves the right to either postpone or to cancel the entire process of tender.
29. If Employer wishes to engage third party consultants for quality control assessment, apart from the Employer quality control and field tests, the Tenderer should co-operate with both Quality control authorities and the third party.
30. Building and other construction workers welfare: The Tenderer shall subscribe 1% of gross amount of each bill payable to him in respect of contract to the building and other construction workers welfare cess as per GO No: LD 300 LET 2006, Bangalore, dated: 18-01-2007. The amount of subscription will be recovered out of payable amount to him in each bill. This component is deemed to have been included in the quoted rate.
31. **Last Date of Receipt and opening of Bids:** The completed Tenders must be submitted through Karnataka Public Procurement Portal <https://eproc.karnataka.gov.in> not later than 15.00 Hrs on **10/10/2022** and shall be opened on **11/10/2022** at 15.30 hrs. K-RIDE will not be responsible for any delays in the receipt of Tender by K-RIDE. Late Tenders (received after stipulated date and time of submission of Tenders) shall not be accepted under any circumstances. K-RIDE reserves the right to accept/reject any or all proposals without assigning any reason thereof.
32. Any suit or application, arising out of any dispute or differences on account of this tender shall be filed in a competent court at Bengaluru, Karnataka only and no other court or any other district of the country shall have any jurisdiction in the matter.
33. **Address for Communication:** Interested eligible Tenderers may obtain further information from the following address:

GM/S&T,
Rail Infrastructure Development Company (Karnataka) Limited,
#8, 1st Floor, Samparka Soudha, Dr. Rajkumar Road, Opposite Orion Mall
Rajajinagar 1st Block, Bengaluru-560010
Tel +91-6364890850
E-mail: s.nageswararao.kride@ka.gov.in, gmst@kride.in

For any Query regarding e tendering portal/ Tender submission please contact
helpdesk Number [+91-8046010000](tel:+91-8046010000), [+91-8068948777](tel:+91-8068948777)
Email: support@eprochelpdesk.com

SECTION – 2

INSTRUCTIONS TO TENDERERS (ITT)

SECTION 2: INSTRUCTIONS TO TENDERERS (ITT)
TABLE OF CLAUSES

SL.NO	DESCRIPTION	PAGE NO
	A. GENERAL	
1	SCOPE OF TENDER	9
2	ELIGIBLE TENDERERS	9-12
3	QUALIFICATION OF THE TENDERER	12-18
4	ONE TENDER FOR TENDERER	18
5	COST OF TENDERING	18
6	SITE VISIT	18
	B. TENDER DOCUMENTS	
7	CONTENT OF TENDER DOCUMENTS	19
8	CLARIFICATION OF TENDER DOCUMENT	19
9	AMENDMENT OF TENDER DOCUMENTS	19
	C. PREPARATION OF TENDERS	
10	DOCUMENTS COMPRISING THE TENDER	20
11	TENDER PRICES	20
12	TENDER VALIDITY	20-21
13	EARNEST MONEY DEPOSIT	21
14	FORMAT AND SIGNING OF TENDER	21-23
	D. SUBMISSION OF TENDERS	
15	SEALING AND MARKING OF TENDERS	23
16	DEADLINE FOR SUBMISSION OF TENDERS	23
17	LATE TENDERS	23
18	MODIFICATION AND WITHDRAWAL OF TENDERS	23-24
	E. TENDER OPENING AND EVALUATION	
19	OPENING OF FIRST COVER (DOCUMENT) OF ALL TENDERS AND EVALUATION TO DETERMINE QUALIFIED TENDERERS	24
20	OPENING OF SECOND COVER (DOCUMENT) TENDERS OF QUALIFIED TENDERS AND EVALUATION	24-25
21	PROCESS TO BE CONFIDENTIAL	25
22	CLARIFICATION OF TENDERS	25
23	EXAMINATION OF TENDERS AND DETERMINATION OF RESPONSIVENESS	25-26
24	CORRECTION OF ERRORS	26
25	EVALUATION AND COMPARISON OF TENDERS	26
	F. AWARD OF CONTRACT	
26	AWARD CRITERIA	27
27	EMPLOYER'S RIGHT TO ACCEPT ANY TENDER AND TO REJECT ANY OF ALL TENDERS	27
28	NOTIFICATION OF AWARD AND SIGNING OF AGREEMENT	27
29	PERFORMANCE SECURITY	27-28
30	ADVANCE PAYMENT AND SECURITY	28
31	CORRUPT OR FRAUDULENT PRACTICES	28
32	PURCHASE PREFERENCE TO MAKE IN INDIA	28-29
33	APPEAL	29
	Additional Instructions	29-42

A. GENERAL**1. SCOPE OF THE TENDER:**

1.1 THE RAIL INFRASTRUCTURE DEVELOPMENT COMPANY (KARNATAKA) LIMITED (K-RIDE), having its Corporate office, at #8, 1st Floor, Samparka Soudha, Dr. Rajkumar Road, Opposite Orion Mall, Rajajinagar 1st Block, Bengaluru-560010, India, which is a Joint Venture of Government of Karnataka and Ministry of Railways invites Tenders from Eligible Tenderers, for Signaling outdoor and indoor works with Distributed Electronic interlocking (EI) at Yesvantpur Jn. in connection with doubling of Yesvantpur-Channasandra section of Bangalore Division. Further details are given in the invitation for the Tenders (IFT). The tenderers may submit the tenders for the works detailed in the IFT.

2. ELIGIBLE TENDERERS:

2.1 The Tenderers shall not be under a declaration of ineligibility for corrupt and fraudulent practices issued by Govt. of Karnataka, Govt of India and PSUs.

2.2 JOINT VENTURES:

Tendering by a joint venture of Contractors is permissible subject to following conditions:

- a. If the Applicant comprises a number of firms combining their resources in a joint venture, the legal entity constituting the joint venture and the individual partners in the joint venture shall be registered after award of work and shall not be under a declaration of ineligibility for corrupt and fraudulent practices issued by GOK.
- b. The joint venture must satisfy collectively the Qualification criteria. For this purpose, the following data of each member of the joint venture may be added together to meet the collective qualifying criteria:
 - i. Average annual turnover (sub clause 3.2a).
 - ii. Particular experience including key production rates. (Sub clause 3.2b & c).
 - iii. Financial means (sub clause 3.3b liquid assets, 3.6 assessed available Tender capacity & the audited balance sheets or other financial statements acceptable to the employer, for the last five years shall be submitted and must demonstrate current soundness of the applicant's financial position and indicates its prospective long-term profitability.
 - iv. Personnel capabilities (sub clause 3.3c: List of minimum key staff/position required during the contract implementation).
 - v. Equipment capabilities (sub clause 3.3a: own/lease equipment's).
- c. Each partner must satisfy the following criteria individually:
 - i. General construction experience for the period of years stated in Tender document (Instructions to Tenderers: The intending Tenderer/firm/company/ joint venture shall provide evidence that it has been actively engaged in "Execution of any signaling and Telecom works (EI/RR/PI/Auto block signaling/IBH/IBS/LC gate/BPAC/OFC/6Quad cable laying)" work for at least for a period of 5 years prior to the submission of application.) (From FY: 17-18 to FY: 21-22)
 - ii. Adequate sources to meet financial commitments on the other contracts (Sub clause 3.5: Accessed availed Tender capacity).

- iii. **Financial Soundness (Instructions to Tenderers:** The intending Tenderer/firm/company shall provide the **audited balance sheets** or other financial statements acceptable to the employer for the last five years and must demonstrate the current soundness of the applicant's financial position and indicate its prospective long-term profitability. If deemed necessary, the employer shall have the authority to make enquiries with the applicants' bankers).
- iv. **Litigation History (Instructions to Tenderers:** The intending Tenderer/firm/company/ joint venture shall provide accurate information on the related application form about any litigation or Arbitration resulting from contracts completed or on going under its execution over the last five years. The consisting history of awards against the tenderer or any partner of a joint venture may result in failure of the application).
- v. In accordance with the above, the Application shall include all related information required for individual partners in the joint venture
- d. **Joint venture is restricted to 2 (Two) number of partners.** One of the partners, who is responsible for performing a key function in contract management or is executing a major component of the proposed contract, shall be nominated as being in charge during the tendering periods and, in the event of a successful tender, during contract execution. The partner in charge shall be authorized to incur liabilities and receive instructions for and on behalf of any and all partners of the joint venture; this authorization shall be evidenced by submitting a power of attorney signed by legally authorized signatories of all the partners.
- e. All partners of the joint venture shall be legally liable, jointly and severally, during the tendering process and for the execution of the contract in accordance with the contract terms, and a statement to this effect shall be included in the authorization mentioned under Sub-Clause 2.2(d) above. **To enable the above, each of the partners of the joint venture shall meet not less than 25% of the qualifying criteria specified for Average annual turnover and Line of credit / liquid assets. All members of the joint venture must have experience in execution of similar work.**
- f. A copy of the Joint Venture Agreement (JVA) entered into by the partners shall be submitted with the Application. Pursuant to Sub-Clauses 2.2(c) to 2.2(f) above, the JVA shall include among other things: the JV's objectives; the proposed management structure; the contribution of each partner to the joint venture operations; the commitment of the partners to joint and several liability for due performance; recourse/sanctions within the JV in the event of default or withdrawal of any partner; and arrangements for providing the required indemnities.
The lead partner shall enter into a Joint Venture agreement of Rs. 200.00 stamp paper in the prescribed format which shall be concluded prior to Tender and enclosed to the Tender document J.V. Partner shall not enter in to multiple J.V's with different Tenderers of the same work.
- g. The qualification of a joint venture does not necessarily qualify any of its partners to tender individually or as a partner in any other joint venture or association. In case of dissolution of a joint venture prior to the submission of tenders, any of the constituent firms may qualify if they meet all of the qualification requirements, subject to the written approval of the employer. Individual members of a dissolved joint venture may participate as sub-contractor to qualified applicants, subject to the provisions mentioned below:

SECTION:2: - INSTRUCTIONS TO TENDERERS (ITT)

- “No firm can be a sub-contractor while submitting a tender individually or as a partner of a joint venture in the same tendering process. A firm, if acting in the capacity of sub-contractor in any tender, may participate in more than one tender, but only in that capacity. A tenderer who submits, or participates in, more than one tender will cause all the proposals in which the tender has participated to be disqualified.”
- A firm shall submit only one Tender in the same Tendering process, either individually as a Tenderer or as partner of Joint Venture.
- The necessary certificates/documents in support of pre-qualification criteria fulfilled as stipulated shall be scanned and attached to e-tender document. Scanned signature of the Tenderer/authorized representatives of the Tenderer shall be attached while uploading the Tender document.

Any Tenderer who is otherwise technically qualified withdraws from the Tender process at any stage before a final decision is taken on the tender, the EMD of such Tenderer shall be forfeited, the name of such Tenderer shall be removed from the category list of contractors at least for a minimum period of one year in K-RIDE beside making such Tenderer liable for blacklisting.

- Tenders submitted by all Tenderers in the process of Tender evaluation will be opened even if the Tenderer withdraws from the Tender process by not submitting the original documents for verification or for any other reasons and the prices quoted by them will be looked into, to ascertain if there is collision amongst the Tenderers to determine the competitiveness of the L1 price quoted by other Tenderers, as per the decision by the K-RIDE.
- Prior to awarding of the work, the Lowest (L-1) Tenderer should produce the original documents in support of the uploaded documents to enter in to the agreement. If the lowest Tenderer (L-1) does not produce the original documents for entering into the agreement then his Tender can be treated as non-responsive Tender as per clause 26(4) of the KTPP Rules. The name of the Tenderers who do not produce the original documents shall be removed/debarred from the select list of K-RIDE enrollment and barred from participation in any of the tenders to be invited by K-RIDE a part from forfeiting the EMD paid through e-cash.
- The bidder/JV Partner shall not be under Corporate Debt Restructuring (CDE)/ Strategic Debt Restructuring (SDR) or Bureau of Industrial & financial reconstruction (BIFR) in last 5 years to bid submission date. In this regard, the bidder shall submit along with bid, a certificate with a declaration that, the bidder is not under CFR/SDR or BIFR.
- Further information about e-tendering can be had from Karnataka Public Procurement Portal <http://eproc.karnataka.gov.in>

3. QUALIFICATION OF THE TENDERER.

3.1 All the tenderers shall provide the requested information accurately and sufficient details in section 3: Qualification information. The Joint Venture to be formed prior to the Bidding.

Pre-qualification will be based on Applicants meeting all the following minimum pass–fail criteria regarding their general and particular construction experience, financial position, personnel and equipment capabilities, and other relevant information as demonstrated by the Applicant's responses in the Information Forms attached to the Letter of Application. Additional requirements for joint ventures are given in para 2.2

3.2 The following qualification criteria should be met by the intending Tenderers.

a) Required average annual turnover (In all classes of S&T construction work only): The intending Tenderer/firm/ Company/Joint Venture should have achieved a **MINIMUM AVERAGE ANNUAL CONSTRUCTION TURNOVER of 26.78 Crore of the tender in last five financial years from 2017-18 to 2021-22.**

NOTE: The Tenderers shall submit certificates to this effect which may be **attested certificates** from the concern **departments/ Client** or **Audited balance sheet** duly certified by the chartered accountant/ certificate from Chartered Accountant duly supported by audited balance sheet. The Turnover certificate duly certified by statutory Auditor should be uploaded. Financial turnover of previous years will be given a weightage of 10% per year as indicated in qualification information (Tender Forms) Form FIN-2 based on the rupee value to bring them to current FY: 2022-23 price value.

b) The Tenderer/Firm/Company/JV should have satisfactorily completed at least one similar work such as **“Execution of any signalling works (EI/RR/PI/Auto block signalling/IBS/IBH) either outdoor or indoor or both”** of value not less than **Rs. 13.39 Crores at current FY: 2022-23 price level in the last five financial years. (FY 2017-18 to FY 2021-22)**

Note for similar work: While bidding in the tender for EI/MSDAC/SSBPAC/Fire detection and alarm, the bidder must take OEM/its RDSO approved Indian partner's authorized breakup of numbers of each cards/modules and other accessories. It includes spares card break up and shall submit the authorization of RDSO approved source (OEM or its RDSO approved source) from which these items are being taken. After the award of the contract, MOU with same RDSO approved source whose authorization is taken at the time of bidding covering supply of the equipment, installation, testing and commissioning of equipment by the same RDSO approved source including after sales-support required during the warranty period and beyond the warranty period, before supply of equipment is undertaken.

NOTE:

1. The criteria above applies to the Individual Tenderer/Firm/company/Joint venture also. Certificate regarding the same duly signed by an officer not below the rank of the Executive Engineer to be submitted along with the technical Tender.

2. Similar work is defined as below:

Execution of any signalling works (EI/RR/PI/Auto block signalling/IBS/IBH) either outdoor or indoor or both.

Note for similar work: While bidding in the tender for EI/MSDAC/SSBPAC/Fire detection and alarm, the bidder must take OEM/its RDSO approved Indian partner's authorised breakup of numbers of each cards/modules and other accessories. It includes spares card break up and shall submit the authorization of RDSO approved source (OEM or its RDSO approved source) from which these items are being taken. After the award of the contract, MOU with same RDSO approved source whose authorization is taken at the time of bidding covering supply of the equipment, installation, testing and commissioning of equipment by the same RDSO approved source including after sales-support required during the warranty period and beyond the warranty period, before supply of equipment is undertaken.

3. The contract is considered as completed if 80% or more of the work is physically completed which is to be substantiated by a **certificate from the Employer** who has awarded the contract to the Bidder and the contract amount so received should be equal to or more than the minimum value as per eligibility criteria 3.2 (b).
4. For completed works, the value of work done shall be updated to FY 2022-23 price level assuming 10% inflation for Indian rupees every year. Credentials if submitted in foreign currency shall be converted into Indian currency i.e., Indian Rupee as under: Bids will be compared in Indian Rupees only. This will be achieved by conversion of the Foreign Currency portion of the Bid into Indian Rupees by using the Exchange Rates published by Financial Benchmarks India Pvt. Ltd (www.fbil.org.in) 28 (twenty-eight) days before the latest date of Bid submittal, and then adding the same to the Indian Rupee portion of the Bid. In case this particular day happens to be a holiday, the exchange rate published by Financial Benchmarks India Pvt. Ltd (www.fbil.org.in) on the next working day will be considered.
5. In case of JV/Consortium, full value of the work, if done by the same JV shall be considered. However, if qualifying work (s) done by them in JV/Consortium having different constituents, then the value of work as per their percentage participation in such JV/Consortium shall be considered.
- c) The intending Tenderer / firm/ company / Joint Venture should have executed all the components within last five financial years and Each component should have been executed in any one year (Any continuous 12 months).

Component No.	Nature of Work	Minimum component of work
1	Commissioning of signaling works (EI/RR/PI/Auto block signaling) in station either outdoor or indoor or both	1 Major station OR 3 minor stations

NOTE: -

1. The criteria above apply to the Individual Tenderer/Firm/ company / Joint Venture also. Certificate regarding the same duly signed by an officer not below the rank of the Executive Engineer should be submitted along with the technical Tender.
2. The qualifications, capacity, and resources of proposed subcontractors will not be taken into account in assessing those of individual or joint venture Applicants, unless they are named specialist subcontractors.
3. Minor stations less than 50 routes, Major station which is having more than 200 routes in any S/L or D/L or Auto signalling sections.

3.3 Each Tenderer should further demonstrate:

- 3.3 a) KEY PLANT AND EQUIPMENT: Availability by owning at least 50% of the required following key and critical equipment's for this work and the remaining 50% can be deployed on lease/hire for all works provided, the relevant documents (Commitment agreements etc.,) for availability for this work are to be furnished:**

The intending Tenderer/firm/company/Joint venture should furnish details of ownership / lease certificates of the following minimum requirement of machineries:

PLANT AND EQUIPMENT**(I) KEY AND CRITICAL EQUIPMENTS**

SI No.	Type of Equipment required for the work	Proposed to be Deployed (Minimum)	Remarks
1.	Portable Generators of all capacities as per site requirement	2 Nos.	
2.	Drilling machines of all type as per site requirement	2 Nos	
3.	Track Drilling machines of all type (mechanical cycle chain type and electrical type) as per site requirement	2 Nos	
4.	Grinders of all types as per site requirement	2 Nos.	
5.	Jacks for cable Laying	2 Sets	
6.	Concrete Shutters for Apparatus case FULL	4 Sets	
7.	Concrete Shutters for Apparatus case Half	2 Sets	
8.	Concrete Shutters for Signal Post	2 Sets	
9.	Concrete Shutters for Shunt Signal	1 Sets	
10.	Tool Kits for fitters – Mechanical Installation gang (Location Box / Apparatus cases, Signals, etc.)	02 Sets	

SECTION:2: - INSTRUCTIONS TO TENDERERS (ITT)

11.	Tool kit for fitters – Electro-mechanical gang (Track circuiting, Point machines, Axle counters, Circuits controllers, Level locks & relay Rack equipment.)	02 Sets	
12.	Tool kit for locking fitters cum LC gate interlocking. Key lock point interlocking & ground level frame interlocking.	1 Sets	
13.	Wireman's tool kit consisting of Multimeter, Meggar, Box spanner, Nose Plier, Holding Plier, buzzer, wooden hammer, Clamp type ampere meter etc.	04 Sets	
14.	Carpenter tool kit	1 Sets	
15.	Earth tester	1 Set	
16.	Torches	8 Nos.	
17.	Material loaders / Mini trucks /Matadors / Bolero's	2 Nos.	
18.	VHF – Walkie Talkies Sets	2 Sets	

(II) **Other Plant and equipment to be deployed (The Tenderer has to furnish the details of Own basis and Lease/Hire basis for the following equipment**

--- NIL --

3.3 b) LIQUID ASSETS: The Tenderer / firm/company/Joint Venture should furnish details of liquid assets and or availability of credit facilities of Rs. 5.95 Crores for the work mentioned above for meeting the required funds in the form of own funds /credit lines / certificate from scheduled Nationalized Bank.

The Bidder should have access to or has available liquid assets, lines of credit and other financial means to meet cash flow. The audited balance sheet and/or banking reference certified by Chartered Accountant with their stamp, signature and membership number shall be submitted by the Tenderer along with the Tender.

Banking reference should contain in clear terms the amount that bank will be in position to lend for this work to the applicant/member of the joint venture/Consortium. In case the Net Current Assets (as seen from the balance sheet) are negative, only the banking references will be considered. Otherwise, the aggregate of Net Current Assets and submitted banking references will be considered for working out the Liquidity.

The banking reference should be, from a scheduled Bank in India it should not be more than three months old as on date of submission of Bids.

In case of JV firm's overall liquidity of JV firm shall be assessed by arithmetic sum of liquidity of all members of JV as specified in JV matrix.

3.3 c) LIST OF MINIMUM KEY TECHNICAL PERSONNEL: List of Minimum Key Technical personnel required for the work are as under and should be enrolled in company/ firm/Joint Venture under Employment register and document should be uploaded. The

Contractor shall have a competent team of Managers, Engineers, Technical staff etc. so as to complete the work satisfactorily as per various requirements of the contract. The Key Positions not limited to and corresponding qualification and experience are as under:

Sl. No.	Designation	Qualification	Experience level (For similar works)	Min. No. Required
1	Sr. Engineer	Engineering Graduate in Electronics/Elect.	3 years' Experience in construction of EI/RR/PI	2
2	Supervisors/ S&T	Diploma in Electronics/Elect.	Minimum 3 years' experience in construction of EI/RR/PI	2
3	Draftsman with knowledge of AUTOCAD S&T	Minimum Diploma in Electrical/Electronic s/Communication Engineering OR a combination of basic streams of Electrical/Electronic s/Communication Engg.	3 years with AutoCAD (S&T) experience.	1
4	Wire man	Wireman	Minimum Experience of 5 years	6 WireMen + 8 Asst. WireMen per station during Pre NI & NI

Note: The CV's to be given for Serial No. 1 to 3 as per Form-6 of section- (Qualification information /Bidding Forms).

- 3.4 To qualify for a package of contracts made up of this and other contracts for which tenders are invited in this IFT, the Tenderer must demonstrate having experience and resources to meet the aggregate of the qualifying criteria for the individual contracts.**
- 3.5 Sub-contractors' experience and resources shall not be taken into account in determining the Tenderer's compliance with the Qualifying Criteria.**
- 3.6 BID CAPACITY: Tenderers who meet the above specified minimum qualifying criteria, will only be qualified, if their available tender capacity is more than the total tender value (Rs 26.78 crore). The available tender capacity will be calculated as under:**

Assessed available tender capacity = (A*N*1.5 - B) Where

A = Maximum value of S&T works executed in any one year during the last five financial years ending 31.03.2022 taking into account the completed as well as works in progress.

SECTION:2: - INSTRUCTIONS TO TENDERERS (ITT)

N = Number of years prescribed for completion of the works for which tenders are invited.

B = Value at current price level (updated to FY 2022-23 price level) of existing commitments and on-going works to be completed during the next two and half years (*period of completion of the works for which Tenders are invited*).

Note: Updation of Price Level shall be done at 10% per year.

The statements showing the value of existing commitments and on-going works as well as the stipulated period of completion remaining for each of the works listed should be countersigned by the Employer in charge, not below the rank of an Executive Engineer or equivalent.

3.7 NETWORTH: The Bidder's net worth for the last Financial Year calculated as the difference between total assets and total liabilities **should be Positive**.

3.8 Even though the Tenderers meet the above criteria, they are subject to be disqualified if they have:

- made misleading or false representations in the forms, statements and attachments submitted in proof of the qualification requirements; and/or
- record of poor performance such as abandoning the works, not properly completing the contract, inordinate delays in completion, litigation history, or financial failures etc.; and/or
- participated in the previous Tender for the same work and had quoted unreasonably high tender prices and could not furnish rational justification.

3.9 ELIGIBILITY CRITERIA TABLE/MATRIX:

Requirement	Single Entity	Joint Venture			Submission Requirements
		Lead Partner	Other Partners	All partners combined	
Clause: 3.2.(a) (Annual construction turnover in at least two out of five financial years)	Must meet the requirement	Must meet 50% of the requirement	Must meet 25% of the requirement	Must meet the requirement	Form FIN-2
Clause: 3.2 (b) One Similar work	Must meet the requirement	Must meet the requirement	Must have experience in similar work.	Must meet the requirement	Form at para 1.3/section:3
Clause: 3.2 (c) 1 Commissioning of signaling works (EI/RRR/PI/Auto block signaling) in station either outdoor or indoor or both	Must meet the requirement	All Partners Combined Must Meet requirement			Form at para 1.4/section:3
Clause: 3.3 (I) Key and Critical Equipments	Must meet the requirement	All Partners Combined Must Meet requirement.			Form at para 1.6/section:3
Clause: 3.3 (II) Other plant and Equipments	Must meet the requirement	All Partners Combined Must Meet requirement			Form at para 1.6/section:3

SECTION:2: - INSTRUCTIONS TO TENDERERS (ITT)

Clause: 3.3(b) Liquid Asset	Must meet the requirement	Must meet 50% of the requirement	Must meet 25% of the requirement	Must meet the requirement	Form at para 1.10/section:3
Clause: 3.3(c) Minimum Key Technical Staff	Must meet the requirement	All Partners Combined Must Meet requirement			Form No.5 & 6 of Section 3
Clause: 3.6 Bid capacity	Must meet the requirement	All Partners Combined Must Meet requirement			Form at para 1.5/section:3 and Form FIN-3/ section:3
Clause: 3.7 Net worth	Must meet the requirement	Must meet the requirement	Must meet the requirement	Must meet the requirement	Form FIN-1/ section:3

3.10 The applicant must attach with their application, a note giving a general description on the approach to the construction methods, technologies, quality assurance schemes proposed, deployment schedule of equipment proposed to be used, etc., for ensuring completion of the work as per specifications within the desired time-frame.

4. ONE TENDER PER TENDERER:

4.1 Each tenderer shall submit only one tender for one package. A tenderer who submits or participates in more than one Tender (other than as a sub-contractor or in cases of alternatives that have been permitted or requested) will cause all the proposals with the Tenderer's participation to be disqualified.

5. COST OF TENDERING:

5.1 The tenderer shall bear all costs associated with the preparation and submission of his tender, and the Employer will in no case be responsible and liable for those costs.

6. SITE VISIT:

6.1 The Tenderer at his own responsibility and risk is encouraged to visit and examine the Site of Works and its surroundings and obtain all information that may be necessary for preparing the Tender and entering into a contract for construction of the Works. The cost of visiting the Site shall be at the Tenderer's own expense.

B -TENDER DOCUMENTS

7. CONTENT OF TENDER DOCUMENTS

7.1 The set of tender documents shall have all the Sections given in content page.

8. CLARIFICATION OF TENDER DOCUMENTS

8.1 A prospective tenderer requiring any clarification of the tender documents may notify the Employer in writing or by cable (hereinafter "cable" includes telex, E-Mail and facsimile) at the Employer's address indicated in the invitation to tender. The Employer will respond to any request for clarification which he receives earlier than 15 days prior to the deadline for submission of tenders. Copies of the Employer's response will be forwarded to all purchasers of the tender documents, including a description of the enquiry but without identifying its source.

8.2 Pre-tender meeting:

8.2.1 The tenderer or his authorized representative is invited to attend a pre-tender meeting which will take place at office of **K-RIDE Bangalore.**

Venue: #8, 1st Floor, Samparka Soudha, Dr. Rajkumar Road,
Opposite Orion Mall, Rajajinagar 1st Block,
Bengaluru-560010
Tel +91-6364890850

Date: 16/09/2022, **Time:** IST 11.30 Hrs.

8.2.2 The purpose of the meeting will be to clarify issues and to answer questions on any matter that may be raised at that stage.

8.2.3 The tenderer is requested to submit any questions in writing or by cable to reach the Employer not later than one week before the meeting.

8.2.4 Minutes of the meeting, including the text of the questions raised (without identifying the source of enquiry) and the responses given will be published without delay to all purchasers of the tender documents. Any modification of the tender documents listed in Sub-Clause 7.1 which may become necessary as a result of the pre-tender meeting shall be made by the Employer exclusively through the issue of an Addendum pursuant to Clause 9 and not through the minutes of the pre-tender meeting.

8.2.5 Non-attendance at the Pre-Tender meeting will not be a cause for disqualification of a Tenderer.

9. AMENDMENT OF TENDER DOCUMENTS

9.1 Before the deadline for submission of Tenders, the Employer may modify the tender documents by issuing addendum

9.2 Any corrigendum / addendum issued shall be part of the tender documents and shall be made available on the website or e-portal. The Provisions in corrigendum /addenda shall take priority over the Tender Documents issued previously.

9.3 To give prospective Tenderers reasonable time in which to take an addendum into account in preparing their tenders, the Employer shall extend as necessary the deadline for submission of Tenders, in accordance with Sub-Clause 16.2 below.

C. PREPARATION OF TENDERS

10. DOCUMENTS COMPRISING THE TENDER

10.1 The Tender submitted by the Tenderer shall be in two covers (documents) and shall contain the documents as follows:

10.1.1 First Cover (Document):

- Scanned copy of Bank Guarantee (B.G) for balance Earnest Money Deposit;
- Qualification Information as per formats given in Section 3;

10.1.2 Second Cover (Document):

- The Tender (in the format indicated in Section: 4) (as per Karnataka Public Procurement Portal)
- Priced Schedule (Section 9); online through Karnataka Public Procurement Portal, no hardcopy of commercials should be attached or disclosed. (as per Karnataka Public Procurement Portal)

And any other materials required to be completing and submitting by Tenderers in accordance with these instructions. The documents listed under Sections 3, 4, 6 and 9 shall be filled in without exception.

10.2 Tenderers submitting tenders together with other contracts stated in the IFT to form a package will so indicate in the tender together with any discounts offered for the award of more than one contract.

11. TENDER PRICES

11.1 The contract shall be for the whole works as described in Sub-Clause 1.1, based on the Price Schedule submitted by the Tenderer.

11.2 The Tenderer shall fill the single percentage above/below/at par (both in figures and words) for each schedule of the Works described in the Price Schedule along with total tender price (both in figures and words). If any bidder quotes more than one percentage for such schedules, its bid shall be summarily rejected. The rates quoted by the bidder in schedule through Karnataka e-procurement portal will only be considered for evaluation of bids. Rates offered through any other medium or at any other location will not be considered.

11.3 All duties, taxes, and other levies payable by the contractor under the contract, or for any other cause, shall be included in the Price schedule, prices and total Tender Price submitted by the Tenderer.

11.4 The amount quoted by the Tenderer shall be subject to adjustment during the performance of the Contract in accordance with the provisions of Clause of the Conditions of Contract.

12. TENDER VALIDITY

12.1 Tenders shall remain valid for a period not less than **one hundred and eighty days** after the deadline date for tender submission specified in Clause 16. A tender valid for a shorter period shall be rejected by the Employer as non-responsive.

- 12.2 In exceptional circumstances, prior to expiry of the original time limit, the Employer may request that the Tenderers may extend the period of validity for a specified additional period. The request and the Tenderers' responses shall be made in writing or by cable. A Tenderer may refuse the request without forfeiting his earnest money deposit. A Tenderer agreeing to the request will not be required or permitted to modify his tender, but will be required to extend the validity of his earnest money deposit for a period of the extension, and in compliance with Clause 13 in all respects.

13. EARNEST MONEY DEPOSIT (TENDER/BID SECURITY)

- 13.1 Earnest Money Deposit/ Tender security (as per Karnataka Public Procurement Portal). The Tenderer shall furnish, as part of his tender, earnest money deposit in the amount as shown in column 4 of the Table of IFT for this particular work. This earnest money deposit shall be in favour of Rail Infrastructure Development Company (Karnataka) Limited Payable at Bangalore and in the form as mentioned in clause 13.7 (refer additional instructions)
- 13.2 Instruments having fixed validity issued as earnest money deposit for the tender shall be valid for 45 days beyond the validity of the tender.
- 13.3 Any tender not accompanied by an acceptable earnest money deposit and not secured as indicated in Sub-Clauses 13.1 and 13.2 above shall be rejected by the Employer as non-responsive.
- 13.4 The earnest money deposit of unsuccessful Tenderers will be returned within 30 days of the end of the tender validity period specified in Sub-Clause 12.1.
- 13.5 The earnest money deposit of the successful Tenderer will be discharged when the Tenderer has signed the Agreement and furnished the required Performance Security.
- 13.6 The earnest money deposit may be forfeited:
- (A) If the Tenderer withdraws the Tender after tender opening during the period of tender validity;
 - (B) If the Tenderer does not accept the correction of the Tender Price, pursuant to Clause 24; or
 - (C) In the case of a successful Tenderer, if the Tenderer fails within the specified time limit to
 - (i) sign the Agreement; or
 - (ii) furnish the required Performance Security.

14. FORMAT AND SIGNING OF TENDER

Tenderer shall submit the Tender electronically before the submission date and time published in Karnataka Public Procurement Portal. The Tenderer must submit Technical and Financial Tender as described in ITT.

All pages of the tender where entries or amendments have been made shall be initialed by the person signing the tender. The Tender shall contain no alterations or additions, except those to comply with instructions issued by the Employer, or as necessary to correct errors made by the Tenderer, in which case such corrections shall be initialed by the person signing the Tender.

SECTION:2: - INSTRUCTIONS TO TENDERERS (ITT)

Language of Tender	The language of the Tender: English
Technical Tender	Alternative technical solutions are not permitted.
Technical Tender Documents	All the Forms of Section 3: Qualification Information/Bidding Forms.
Alternative Bids/Tenders	Alternative Bids are not permitted.
Currencies of Tender and Payment	The Tenderer shall quote rates as single percentage Above/ Below/At par as per the format for each schedule. The rates quoted by the bidder in schedule through Karnataka e-procurement portal will only be considered for evaluation of bids. Rates offered through any other medium or at any other location will not be considered.
Any amendments such as interlineations, erasures, or overwriting shall be valid only if they are signed or initialed by the Person signing the Tender	<p>The written confirmation of authorization to sign on behalf of the Tenderer shall consist of:</p> <ol style="list-style-type: none"> In case of Private/Public Companies, a POA from the Director of the Company who has been authorized by the Board of Directors through resolution to sign on behalf of the Company. Copy of Board Resolution shall also be submitted. In case of proprietorship Tenderers, Power of Attorney by the Proprietors. In case of partnership Tenderers, Power of Attorney duly signed by all the partners. In case of Limited Liability Partnership (LLP), a POA from the Director of the Company who has been authorized by the Board of Directors through resolution to sign on behalf of the Company. Copy of Board Resolution shall also be submitted. In case of Joint Venture, Power of Attorney duly signed by individual partners to the Lead partner as per the form given in Section-4 with stipulated documents.

The Bid shall be digitally signed by using class-III digital signature of a person who is dully authorized to sign on behalf of the bidder. This authorization shall consist of a written confirmation as specified in the BDS and shall be attached to the bid. The name and position held by each person signing the authorization must be typed or printed below the signature. If either the Letter of Technical Bid or Letter of Price Bid or Bid-Security Declaration (if applicable) is not signed, the Bid shall be rejected. All pages of the bid, except for un-amended printed literature, shall be signed or initialed by the person signing the bid.

- If the Tender is submitted by proprietary firm, it shall be signed by the proprietor above his full name, full name of his firm with his current address.
- If the Tender is submitted by a firm in partnership, it shall be signed by a partner holding the power of Attorney for the firm. A certified copy of the Partnership deed and power of attorney shall accompany the Tender; Alternatively, it shall be signed by all the partners.

- III. If the Tender is submitted by a limited company or a limited corporation, it shall be signed by a duly authorized person holding the power of attorney for the firm. A certified copy of the power of attorney shall accompany the Tender.
- IV. If a Tender is submitted by a Joint venture/Consortium, each firm in the Joint venture/Consortium shall furnish the evidence admissible in law /Power of Attorney to sign the Form of Tender and Lead member as stated in JV Agreement shall sign the Tender documents for submission of Tender.

Any amendments such as interlineations, erasures, or overwriting shall be valid only if they are signed or initialed by the person signing the Tender

D. SUBMISSION OF TENDERS

15. SEALING AND MARKING OF TENDERS

Tenderer shall submit the Tender electronically before the submission date and time published.

16. DEADLINE FOR SUBMISSION OF THE TENDERS

- 16.1 Tenders must be submitted online through Karnataka Public Procurement Portal to the Employer on or before the date as specified in the Karnataka Public Procurement Portal and the submission of tender is the responsibility of the Tenderer.
- 16.2 The Employer may extend the deadline for submission of tenders by issuing an amendment in accordance with Clause 9, in which case all rights and obligations of the Employer and the Tenderers previously subject to the original deadline will then be subject to the new deadline.

17. LATE TENDERS

- 17.1 In online e-procurement system, the Tenderer shall not be able to submit the Tender after the Tender submission time and date as the icon for the task in the Karnataka Public Procurement Portal will not be available. Any Tender received by the Employer after the deadline prescribed in Clause 16 will be rejected.
- 17.2 "It shall be the responsibility of the tenderers to ensure that their tender is submitted in the Karnataka public procurement portal within the last date and time specified for the receipt of the tenders

18. MODIFICATION AND WITHDRAWAL OF TENDERS

- 18.1 Tenderer may modify and correct or upload any relevant document in the portal till Tender submission date and time, as published in the Karnataka Public Procurement Portal.
- 18.2 No Tender may be modified after the deadline for submission of Tenders.

- 18.3 Withdrawal or modification of a Tender between the deadline for submission of Tenders and the expiration of the original period of Tender validity specified in Clause 12.1 above or as extended pursuant to Clause 12.2 may result in the forfeiture of the earnest money deposit pursuant to Clause 13.
- 18.4 Tenderers may modify the percentages of their Tender schedules by submitting Tender modifications in accordance with this clause, or included in the original Tender submission.

E. TENDER OPENING AND EVALUATION

19. OPENING OF FIRST COVER (Document): Opening of First Cover (Document) of all Tenders and evaluation to determine qualified Tenderers:

- 19.1 The Employer will open the First Covers (Document) of all the Tenders received (except those received late or withdrawn), including modifications for First Cover (Document) made pursuant to Clause 18, in the presence of the Tenderers or their representatives who choose to attend as per Karnataka e-Procurement Portal on the date and the place specified in Clause 16. In the event of the specified date of Tender opening being declared a holiday for the Employer, the Tenders will be opened at the appointed time and location on the next working day.
- 19.2 DELETED
- 19.3 The Tenderer name, the presence or absence of earnest money deposit (amount, format and validity), the submission of qualification information and such other information as the Employer may consider appropriate will be announced by the Employer at the opening.
- 19.4 The Employer shall prepare minutes of the Tender opening, including the information disclosed to those present in accordance with Sub-Clause 19.3.
- 19.5 DELETED
- 19.6 The Employer will evaluate and determine whether each tender (a) meets the eligibility criteria defined in ITT Clause 2 is accompanied by the required earnest money deposit as per stipulations in ITT Clause 13 and meets the minimum qualification criteria stipulated in ITT Clause 3. The Employer will draw out a list of qualified Tenderers.

20. OPENING OF SECOND COVER (DOCUMENT) OF QUALIFIED TENDERERS AND EVALUATION:

- 20.1 The Employer will inform all the Qualified Tenderers the time, date and venue fixed for the opening of the Second Cover (Document) containing the priced Tenders published in Karnataka Public Procurement Portal. The Employer will open the Second Covers (Document) of Qualified Tenderers through Karnataka e-procurement portal only at the appointed time and date in the presence of the Tenderers or their representatives who choose to attend. In the event of the specified date of financial Tender opening being declared a holiday for the Employer, the Second Covers (Document) will be opened at the appointed time and location on the next working day.

20.2 DELETED

20.3 The Tenderers' names, the Tender prices, the total amount of each Tender, any discounts, Tender modifications and withdrawals, and such other details as the Employer may consider appropriate, will be announced by the Employer at the opening. No Tender shall be rejected at Tender opening.

20.4 The Employer shall prepare minutes of the Second Cover (Document) Tender opening, including the information disclosed to those present in accordance with Sub-Clause 20.3.

21. PROCESS TO BE CONFIDENTIAL

21.1 Information relating to the examination, clarification, evaluation, and comparison of Tenders and recommendations for the award of a contract shall not be disclosed to Tenderers or any other persons not officially concerned with such process until the award to the successful Tenderer has been announced. Any effort by a Tenderer to influence the Employer's processing of Tenders or award decisions may result in the rejection of his Tender.

22. CLARIFICATION OF TENDERS

22.1 To assist in the examination, evaluation, and comparison of Tenders, the Employer may, at his discretion, ask any Tenderer for clarification of his Tender, including breakdowns of Lumpsum Price. The request for clarification and the response shall be in writing or by cable, but no change in the price or substance of the Tender shall be sought, offered, or permitted except as required to confirm the correction of arithmetic errors discovered by the Employer in the evaluation of the Tenders in accordance with Clause 24.

22.2 No Tenderer shall contact the Employer on any matter relating to its Tender from the time of the Tender opening to the time the contract is awarded.

If they have any query/clarification related to e-Procurement on the Karnataka Public Procurement Portal, contact e-Procurement Help desk from 10:00 AM to 5:00 PM. Ph. No.: +91-8046010000/ 8068948777 or support@eprochelpdesk.com Karnataka Public Procurement Portal through query option on or before specified time.

22.3 Any effort by the Tenderer to influence the Employer in the Employer's Tender evaluation, Tender comparison or contract award decisions may result in the rejection of the Tenderers' Tender.

23. EXAMINATION OF TENDERS AND DETERMINATION OF RESPONSIVENESS

23.1 Prior to the detailed evaluation of Tenders, the Employer will determine whether each Tender; (a) has been properly signed; and; (b) is substantially responsive to the requirements of the Tender documents.

23.2 A Substantially responsive Tender is one which conforms to all the terms, conditions, and specifications of the Tender documents, without material deviation or reservation. A material deviation or reservation is one (a) which affects in any substantial way the scope, quality, or

performance of the Works; (b) which limits in any substantial way, inconsistent with the Tender documents, the Employer's rights or the Tenderer's obligations under the Contract; or (c) whose rectification would affect unfairly the competitive position of other Tenderers presenting substantially responsive Tenders.

- 23.3 If a Tender is not substantially responsive, it will be rejected by the Employer, and may not subsequently be made responsive by correction or withdrawal of the nonconforming deviation or reservation.

24. CORRECTION OF ERRORS

- 24.1 Tenders determined to be substantially responsive will be checked by the Employer for any arithmetic errors. Errors will be corrected by the Employer as follows:
- where there is a discrepancy between the amount in figures and in words, the lower of the two will govern and
 - Deleted.
- 24.2 The amount stated in the Tender will be adjusted by the Employer in accordance with the above procedure for the correction of errors and, with the concurrence of the Tenderer, shall be considered as binding upon the Tenderer. If the Tenderer does not accept the corrected amount the Tender will be rejected, and the earnest money deposit may be forfeited in accordance with Sub-Clause 13.6 (b).

25. EVALUATION AND COMPARISON OF TENDERS

- 25.1 The Employer will evaluate and compare only the Tenders determined to be substantially responsive in accordance with Clause 23.
- 25.2 In evaluating the Tenders, the Employer will determine for each Tender the evaluated Tender Price by adjusting the Tender Price as follows:
- (a) Making any correction for errors pursuant to Clause 24; and
 - (b) Making appropriate adjustments to reflect discounts or other price modifications offered in accordance with Sub Clause 18.5.
- 25.3 The Employer reserves the right to accept or reject any variation, deviation, or alternative offer. Variations, deviations, and alternative offers and other factors which are in excess of the requirements of the Tender documents or otherwise result in unsolicited benefits for the Employer shall not be taken into account in Tender evaluation.
- 25.4 The estimated effect of the price adjustment conditions under Clause 40 of the Conditions of Contract, during the implementation of the Contract, will not be taken into account in tender Evaluation
- 25.5 If the tender of the successful tenderer is seriously unbalanced in relation to the Employer's estimate of the cost of the work to be performed under the contract, the Employer may require the Tenderer to produce detailed price analyses for any or all items of Priced Schedule, to demonstrate the internal consistency of those prices with the construction methods and schedule proposed. After evaluation of the price analyses, the Employer may require that the amount of the performance security set forth in Clause 30 be increased at the expense of the successful Tenderer to a level sufficient to protect the Employer against financial loss in the event of default of the successful Tenderer under the contract.

F. AWARD OF CONTRACT

26. AWARD CRITERIA

Subject to Clause 27, the Employer will award the Contract to the Tenderer whose Tender has been determined to be substantially responsive to the Tender documents and who has offered the lowest evaluated Tender Price, provided that such Tenderer has been determined to be (a) eligible in accordance with the provisions of Clause 2, and qualified in accordance with the provisions of Clause 3.

27. EMPLOYER'S RIGHT TO ACCEPT ANY TENDER AND TO REJECT ANY OR ALL TENDERS

Notwithstanding Clause 26, the Employer reserves the right to accept or reject any Tender, and to cancel the Tender process and reject all Tenders, at any time prior to the award of Contract, without thereby incurring any liability to the affected Tenderer or Tenderers or any obligation to inform the affected Tenderer or Tenderers of the grounds for the Employer's action.

28. NOTIFICATION OF AWARD AND SIGNING OF AGREEMENT

- 28.1 The Tenderer whose Tender has been accepted will be notified of the award by the Employer prior to expiration of the Tender validity period by cable, telex, e-mail or facsimile confirmed by registered letter. This letter (hereinafter and in the *Conditions of Contract* called the "Letter of Acceptance") will state the sum that the Employer will pay the Contractor in consideration of the execution, completion, and maintenance of the Works by the Contractor as prescribed by the Contract (hereinafter and in the Contract called the "Contract Price").
- 28.2 The notification of award will constitute the formation of the Contract, subject only to the furnishing of Performance Security in accordance with the provisions of Clause 29. Until a formal contract is prepared and executed, the notification of award shall constitute a binding Contract.
- 28.3 The Agreement will incorporate all agreements between the Employer and the successful Tenderer. It will be kept ready for signature of the successful Tenderer in the office of Employer within 30 days following the notification of award along with the Letter of Acceptance. Within 20 days of receipt, the successful Tenderer will sign the Agreement and deliver it to the Employer.
- 28.4 Upon the furnishing by the successful Tenderer of the Performance Security, the Employer will promptly notify the other Tenderers that their Tenders have been unsuccessful.

29. PERFORMANCE SECURITY

- 29.1 Within 20 days of receipt of the Letter of Acceptance, the successful Tenderer shall deliver to the Employer a Performance Security in any of the forms given below for an amount equivalent to **3% of the Contract price plus additional security for unbalanced tenders (additional security at 50% of the estimated cost of the unbalanced component)** in accordance with Clause 25.5 of ITT and Clause 43 of the Conditions of Contract.
- Banker's cheque/Demand draft, /Pay Order/ BG in favour of K-RIDE, Bangalore or
 - A bank guarantee in the form given in Section 10; or
 - Specified Small Savings Instruments pledged to K-RIDE, Bangalore.

- 29.2 If the Performance Security deposit is provided by the successful tenderer in the form of Bank Guarantee, it shall be issued either by a Nationalized / Scheduled bank.
- 29.3 The Performance Security deposit if furnished in cash or demand draft can, if requested, be converted to interest bearing securities at the cost of the contractor.
- 29.4 Failure of the successful tenderer to comply with the requirements of sub-clause 30.1 and clause 30 of additional ITT, shall constitute sufficient grounds for cancellation of the Tender award and forfeiture of the Earnest money deposit.

30. ADVANCE PAYMENT AND SECURITY:

- 30.1 The Employer will provide an advance payment on the contract price as stipulated In the condition of contract subject to the maximum as stated In the contract data.

31. CORRUPT OR FRAUDULENT PRACTICES

- 31.1 “corrupt practice” means the offering, giving, receiving or soliciting of anything of value to influence the action of the public official in the procurement process or in contract execution;
- “fraudulent practice” means a misrepresentation of facts in order to influence a procurement process or the execution of a contract to the detriment of the Procurement Entity, and includes collusive practice among the tenderers either prior to or after tender submission, designed to establish tender prices at artificial non-competitive levels and to deprive the Procurement Entity of the benefits of free and open competition;”. The debarment action shall be taken as per KTPP Act.
- 31.2 The K-RIDE requires that the Tenderers/Suppliers/Contractors, observe the highest standard of ethics during the procurement and execution of such contracts. In pursuance of this policy, K-RIDE:
- a) will reject a proposal for award if it determines that the Tenderer recommended for award has engaged in corrupt or fraudulent practices in competing for the contract in question;
 - b) will declare a firm ineligible, either indefinitely or for a stated period of time, to be awarded a K-RIDE contract if it at any time determines that the firm has engaged in corrupt or fraudulent practices in competing for, or in executing, a K-RIDE contract.
- 31.3 Furthermore, Tenderers shall be aware of the provision stated in sub-clause 50.2 of the Conditions of Contract.

32. PURCHASE PREFERENCE TO MAKE IN INDIA:

The provisions of revised 'Public Procurement (Preference to Make in India) Order 2017' issued by Department of Industrial Policy and Promotion under Ministry of Commerce and Industry vide letter no. P-45021/2/2017-PP (BE-II) dated 28.05.2018 shall be applicable to the tendering process and award of the contract shall be done accordingly. In this connection, the minimum local content shall be 50% and the margin of purchase preference shall be 20%. For award of contract, para 3.c. of the revised 'Public Procurement (Preference to Make in India) Order 2017' shall be applicable in addition to the other provisions in the tendering documents in this regard.

- 33. APPEAL:** The Tenderer shall submit online appeal within 30 days period from the date of receipt of order to the Employer through the Karnataka Public Procurement Portal. The Employer may after giving opportunity to the parties pass such order as it deems fit and such order shall be final.

ADDITIONAL INSTRUCTIONS TO TENDERERS
(THIS SHOULD BE READ IN CONTINUATION OF ITT)

ITT Clause Ref.	Description
2.3	<p>The following paras are added:</p> <p>Wherever the word JV is mentioned, it should be read as JV/Consortium.</p> <p>For any purpose herein, 'Joint Venture' means an ad hoc association of firms that pool their resources and skills to undertake a large or complex contract in the role of "Contractor," with all firms (partners in the JV) being legally liable, jointly and severally, for the execution of the Contract in the event of a partner's withdrawal.</p> <p>A Tenderer may be a natural person, private entity, government-owned entity, or any combination of them with a format intent to enter into an agreement or under an existing agreement in the form of a Joint venture or consortium. The Tenderer must ensure the following</p> <p>(a) In case of Single Entity:</p> <p style="padding-left: 20px;">(i) Submit Power of Attorney authorizing the signatory of the Tender to commit the Tenderer.</p> <p>(b) In case of Joint Venture/ Consortium:</p> <p style="padding-left: 20px;">(i) The number of partners in the JV/ Consortium shall not be more than two.</p> <p style="padding-left: 20px;">(ii) At the time of bidding, the tenderer (JV) to submit the JV Agreement, as per the form given in Section 3: Qualification and Information/Bidding Forms. On issue of LOA, the JV/Consortium Agreement should be registered and shall be submitted along with the performance security.</p> <p style="padding-left: 20px;">(iii) The JV/ Consortium shall nominate a Representative through Power of Attorney (Form given in Section 3) who shall have the authority to conduct all business for and on behalf of any and all the parties of the JV/ Consortium during the Tendering process and, in the event the JV/ Consortium is awarded the Contract, during contract execution.</p> <p style="padding-left: 20px;">(iv) Submit Power of Attorney by individual partners to lead partners as per the form given in Section 3.</p> <p style="padding-left: 20px;">(v) In case a Joint Venture/ Consortium is the successful Tenderer, the appropriate Joint Venture/ Consortium Agreement for execution of work should be entered by the Joint Venture/ Consortium.</p>

	<p>Consortium partners. The duly signed Joint Venture/ Consortium Agreement should be submitted along with the tender submission.</p> <p>(vi) The lead member as aforesaid shall be authorized to incur liabilities and receive instructions for and on behalf of any and all the partners of the Joint venture/Consortium and the entire execution of the contract.</p> <p>(vii) All members of the Joint venture/Consortium shall be Jointly and severally responsible for the execution of the Contract.</p> <p>(viii) Change in constitution or percentage participation of JV/Consortium shall not be permitted at any stage after submission of Tenders</p> <p>(c) Only firms that are registered or incorporated in India are eligible to compete. Any Tenderer from a country which shares a land with India will be eligible to Tender in this tender only if the Tenderer is registered with the Competent Authority.</p> <p>(d) "Tenderer from a country which share a land border with India" for the purpose of this Order means: -</p> <ol style="list-style-type: none"> 1. An entity incorporated, established or registered in such a country; or 2. A subsidiary of an entity incorporated, established or registered in such a country; or 3. An entity substantially controlled through entities incorporated, established or registered in such a country; or 4. An entity whose beneficial owner is situated in such a country; or 5. An Indian (or other) agent of such an entity; or 6. A natural person who is a citizen of such a country; or, 7. A consortium or joint venture where any member of the consortium or joint venture falls under any of the above <p>(e) The beneficial owner for the purpose of above clause will be as under:</p> <p>(i) In case of a company or Limited Liability Partnership, the beneficial owner is the natural person(s), who, whether acting alone or together, or through one or more juridical person(s), has a controlling ownership interest or who exercises control through other means.</p> <p>Explanation-</p> <ol style="list-style-type: none"> a. "Controlling ownership interest" means ownership of or entitlement to more than twenty-five percent of share or capital or profits of the company; b. "Control" shall include the right to appoint majority of the directors or to control the management or policy decisions including by virtue their shareholding or management rights or shareholders agreements or voting agreements; <p>(ii) In case of a partnership firm, the beneficial owner is the natural person(s) who, whether acting alone or together, or through one or more juridical person, has ownership of entitlement to more than fifteen percent of capital or profits of the partnership;</p> <p>(iii) In case of an unincorporated association or body of individuals, the beneficial owner is the natural person(s), who, whether acting alone or together, or through one or more juridical person, has ownership of or entitlement to more than fifteen percent of the property or capital or profit of such association or body of individuals;</p>
--	--

- (iv) Where no natural person is identified under (i) or (ii) or (iii) above, the beneficial owner is the relevant natural person who holds the position of senior managing official;
- (v) In case of a trust, the identification of beneficial owner(s) shall include identification of the author of the trust, the trustee, the beneficiaries with fifteen percent or more interest in the trust and any other natural person exercising ultimate effective control over the trust through a chain of control or ownership.

2.4

The Tenderer shall submit a Certificate stating that they have read the above clause using the appropriate Performa given in Section 3 - Form 3C1 & 3C2.

Tenderer having a conflict of interest shall be disqualified. The conflict of interest is detailed below.

A Tenderer or any of its constituents shall not have conflict of interest. All Tenderers found to have a conflict of interest shall be disqualified. A Tenderer may be considered to be in a conflict of interest with one or more parties in this Tendering process, if, including but not limited to::

- (a) they have controlling shareholders in common; or
- (b) they receive or have received any direct or indirect subsidy from any of them; or
- (c) they have the same legal representative for purposes of this Tender; or
- (d) they have a relationship with each other, directly or through common third parties, that puts them in a position to have access to information about or influence on the Tender of another Tenderer, or
- (e) any firm, either individually or in Joint Venture (JV)/ Consortium, submits more than one offer irrespective of whether the firm is quoting against this Tender. The Tenders submitted by two different Tenderers, having any common participant in JV/ Consortium formation or any common partner in partnership firms, or an individual will be treated as having conflict of interest or
- (f) a Tenderer who is Sub-contractor to another Tenderer will be treated as having conflict of interest. However, this does not limit the inclusion of the same sub-contractor in more than one Tender.
- (g) a Tenderer participated as a consultant in the preparation of the design or specifications of the contract that is the subject of the Tender; or
- (h) A Tenderer was affiliated for any period(s) during last two years before the date of issue of Invitation for Tenders with a firm or entity that has been hired (or is proposed to be hired) by the Employer as Engineer for the contract.

2.5

The Tenderer shall be disqualified if:

- (a) The Tenderer or any of its constituents has been blacklisted/ banned from business dealings with all Government Departments by the Government of Karnataka or by Ministry of Railways or by K-RIDE at any time till finalization of Tenders, except in cases where such blacklisting/ banning has been withdrawn by Competent Authority or has ceased or expired on the deadline for submission of the Tenders, for which satisfactory evidence is to be produced.
- (b) Any previous contract of the Tenderer or any of its constituents had been fully terminated or part terminated for its failure as a JV/ Consortium partner with forfeiture of its full Performance Security,

by Rail Infrastructure Development Company (Karnataka) Ltd.(K-RIDE) at any time starting from 3 years before the deadline for submission of Tenders and up to one day before the date of opening of price Tenders;

Provided, however, there is no stay order or declaration by any Court against such termination of the contract by Rail Infrastructure Development Company (Karnataka) Ltd. or such termination of the contract has not been revoked by Rail Infrastructure Development Company (Karnataka) Ltd or competent authority of K-RIDE has not passed an order of non-applicability of disqualification of the Tenderer or any of its constituents despite such termination.

- (c) The Tenderer or any of its constituents has been imposed delay damages of 5% or more of contract value by K-RIDE due to delay in the implementation of any previous contract within the period of last 2 years before the deadline for submission of Tenders (Period of 2 years shall be reckoned from the date on which the total accrued amount of Delay Damages has reached 5% or more of the contract price) or such accrued delay damages has not been fully recovered before the deadline for submission of Tenders on account of contractor's request for deferring recovery to maintain cash flow and K-RIDE has acceded to the same in the interest of the project or the work under the previous contract in question has not been completed before the deadline for submission of Tenders, unless imposition of such delay damages has been set aside by the Competent Authority.
- (d) The Tenderer or any of its constituents:
- (i) has suffered bankruptcy/insolvency or
 - (ii) has any ongoing case of insolvency before the NCLT/ any applicable Court where Interim Resolution Professional (IRP) has been appointed or is at any later stage of the insolvency process, as on the deadline of submission of Tenders or thereafter till finalization of Tenders.
- (e) The Tenderer is found ineligible by the Employer, in accordance with ITB-3.
- (f) The Tenderer or its constituent(s) has been declared by K-RIDE to be a poor performer and the period of poor performance is still in force on the deadline for submission of Tenders.

OR

The Tenderer or its constituent(s) has been declared by K-RIDE to be a poor performer at any time after the deadline for submission of Tenders and upto one day before the date of opening of price Tenders.

- (g) The Tenderer or any of its constituents has changed its name or created a new business entity as covered by the definition of "Allied Firm" under para 1102 (iii) of Chapter XI of Vigilance Manual of Indian Railways (available on website of Indian Railways), consequent to having been banned from business dealings or suspended from business dealings or having been declared poor performer.

The Tenderer shall submit an affidavit stating that they are not liable to be disqualified as per this sub clause using the Form PS3 given in Section-3: Qualification and Information/Bidding Forms. Non-submission of an affidavit by the Tenderer shall result in summary rejection of his Tender.

Tenderers shall immediately inform the Employer in case they cease to fulfil eligibility in terms of ITT **clause 2** above. In case the Tenderer fails to inform the Employer or submits a false affidavit, his Tender shall be summarily rejected and Tender security shall be forfeited. The Tenderer shall also be liable for Banning of Business dealings for a period up to five years

2.6	<p>PARTNERS IN CASE OF JV/CONSORTIUM</p> <p>(i) Lead partner must have a minimum of 50% participation in the JV/Consortium.</p> <p>(ii) Partners having 25% or more percentage participation shall be termed as substantial partner/other Partners.</p> <p>(iii) In case of JV/Consortium, change in constitution or percentage participation shall not be permitted at any stage after the bid submission.</p> <p>The bidder, in case of JV/Consortium, shall clearly and unambiguously define the role and responsibilities for each partner in the JV agreement submitted as per Form JV/4 of Section-3, providing clearly that any abrogation/subsequent re-assignment of any responsibility by any partner of JV/Consortium in favor of other JV/Consortium partner or any change in constitution of partners of JV/Consortium (without written approval of Client) from the one given in JV agreement at tender stage, will be treated, as 'breach of contract condition' and/or 'concealment of facts' as the case may be and acted accordingly. All Members of the JV/ Consortium must have experience in execution of similar work.</p>
3.3(a)	<p>The following para is added:</p> <p>Materials, Equipment and Services</p> <p>The materials, equipment and services to be supplied under the Contract shall be from the approved sources as specified in Section 8A: Works Requirements and Price Schedule Section-9.</p>
7.3	<p>The following para is added:</p> <p>The Employer is not responsible for the completeness of the Bidding Document and their Addenda, if they were not obtained directly from the source stated by the Employer in the Invitation for Bids.</p> <p>The Bidder is expected to examine all instructions, forms, terms, and specifications in the Bidding Document. Failure to furnish all information or documentation required by the Bidding Document may result in the rejection of the bid.</p>
8.3	<p>The following para is added:</p> <p>The Pre-Tender meeting may also be attended through video conferencing (VC). Those Tenderers who wish to join the Video Conferencing shall send a request email on the email id (i.e. gmst@kride.in/ s.nageswararao.kride@ka.gov.in) by 15/09/2022 up to 15:00 hours IST, so that a link for Video Conferencing can be sent by K-RIDE.</p> <p>Please note that the request received from the Tenderers (With details of the Company, its address, and the name and designation of the person attending the VC) will only be entertained. They should also mention the email id through which VC is desired to be joined.</p> <p>K-RIDE may allow maximum of two email ids for one company to participate in the VC. Any request for VC received after the given date and time for sending the link for VC will not be entertained.</p> <p>Prospective Tenderers will be able to join the VC through the link provided to them on Email ID. During this pre- Proposal meeting, prospective Tenderers may request for clarifications.</p>
10.3	<p>The following para is added:</p> <p>Documents Comprising the Tender</p> <ul style="list-style-type: none"> The Tender shall comprise of Bid/Tender Security/Tender Security Declaration, Technical Tender and Price Tender. The Tenderer shall submit the Tender through Karnataka Public Procurement Portal.

- On the stipulated date of opening of Tenders, initially, only the Technical Tenders are opened through Karnataka Public Procurement Portal. The Technical Tenders shall be evaluated by the Employer in accordance with the stipulated Qualification and Evaluation criteria. No amendments or changes to the Technical Tenders would be permitted after the opening of technical Tenders.
- Tenderers who are qualified in the technical evaluation their price Tender shall be opened at a date and time advised by the Employer(K-RIDE) through e-tendering portal. The Price Tenders are evaluated and the Contract is awarded to the Tenderer whose Tender has been determined to be the lowest evaluated substantially responsive Tender.

The Technical Tender shall contain the following:

- All the Forms of Section-3: Qualification Information/Bidding Forms including letter of technical Bid (LTB) shall be scanned and uploaded.
- The Tenderer shall furnish a commitment in Letter of Technical Bid (LTB) for deployment of equipment and personnel as stipulated in Section 8A: Employers Work's Requirement.
- The Tenderer shall furnish commitment in LTB for submitting construction method statement for all major activities of work and get this approved from the engineer prior to the commencement of work on that activity in case of award of contract.
- The Tenderer shall furnish a commitment in Letter of Technical Bid (LTB) for adhering to mobilisation and construction schedule as stipulated in Section 8A: Employers Work's Requirement.
- **Tenderer should note that non-submission of the Letter of Technical Bid (LTB) by the Tenderer shall result in summary rejection of his Tender.**
- Tenderer shall submit the Approach and Methodology for performing the assignment by using appropriate Performa given in Section 3: Qualification Information/Bidding Forms.
- Scanned copy of Tender Security/Tender Security Declaration form (Section 3), in accordance with ITT Clause 13;
- Scanned copy of written confirmation authorizing the signatory of the Tender to commit the Tenderer, any amendments such as interlineations, erasures, or overwriting shall be valid only if they are signed or initialled by the person signing the Tender.
- Scanned copy of documentary evidence with establishing the Tenderer's qualifications to perform the contract; To establish its qualifications to perform the Contract in accordance with Section 2: ITT the Tenderer shall submit as part of its technical Tender the information requested in the corresponding information sheets included in Section 3: Qualification Information/Bidding Forms.

Domestic Tenderers, individually or in joint ventures, applying for eligibility for domestic preference shall supply all information required to satisfy the criteria for eligibility

- Scanned copy of Approach and Methodology - Performa given in Section-3: Qualification Information/Bidding Forms
- Scanned copy of Joint Venture Agreement entered into by all partners

	<ul style="list-style-type: none"> • Scanned copy of Letter of Price Tender. • All Section-3 Documents shall be scanned and submitted. <p>The Price Tender shall contain the following:</p> <ul style="list-style-type: none"> • Filled/completed schedules as required including Price Schedule in accordance with ITT Clauses should be submitted through Karnataka Public Procurement Portal only; • The Tenderer shall submit through Karnataka Public Procurement Portal, separate Technical Proposal and Price Proposal for each individual contract package, using the appropriate Submission Sheets furnished in Section-3: Qualification Information/Bidding Forms. These Forms must be completed without any alterations to their format, and no substitutes shall be accepted. All blank spaces shall be filled in with the information requested. • The Tenderer shall submit, as part of the Price Tender, the Schedules, including the Price Schedule through Karnataka Public Procurement Portal only.
11.5	<p>The following para is added:</p> <p>Tender Prices and Discounts</p> <ul style="list-style-type: none"> • The prices quoted by the Tenderer in the Letter of Price Tender (LPB) and in the Price Schedule shall conform to the requirements specified below. • In the Price Schedule, The Tenderer shall quote rates as single percentage Above/ Below/At par as per the format for each schedule. The rates quoted by the bidder in schedule will only be considered for evaluation of bids. Rates offered through any other medium or at any other location will not be considered. If any Tenderer quotes more than one percentage for such schedules, its Tender shall be summarily rejected. • The price to be quoted in the Letter of Price Tender, in accordance with ITT, shall be the total price of the Tender, excluding any discounts offered. • The Tenderer shall quote any unconditional discounts and the methodology for their application (the discounts, and the methodology of their application, should be quoted on prices quoted in the Tender so that the discounts can be evaluated by simple arithmetic calculation during financial evaluation of the Tenders, to arrive at the net total price of the Tender. If the net total price cannot be calculated after application of the methodology of the discount(s) quoted, the Tender shall be considered as incomplete and will be rejected) in the Letter of Price Tender, in accordance with ITT However, any conditional discount if any offered for award of contract package has to be quoted separately as applicable in Letter of Price Tenders. If Tenderer is not offering any discount for award of combination of contract package, then Tenderer has to quote NIL (zero) discount offered. • The Tenderer can modify his/her Tender and resubmit it any number of times through Karnataka Public Procurement Portal before the deadline for submission of Tenders. Any other correspondence in connection with the Tender is not permissible and shall not be considered in Tender evaluation. • Unless otherwise provided in the ITT and the Contract, the lumpsum amount quoted by the Tenderer are subject to adjustment during the performance of the Contract in accordance with the provisions of the Conditions of Contract. In such a case, the indices and weightages for the price adjustment formulae shall be as specified in the Tables of Adjustment Data included in Contract Data.

SECTION:2: - INSTRUCTIONS TO TENDERERS (ITT)

	<ul style="list-style-type: none"> • If so, indicated in ITT 1, Tenders are being invited for individual contracts or for any combination of contracts (packages). Tenderers wishing to offer any price reduction for the award of more than one Contract shall specify in their Tender the price reductions applicable to each package, or alternatively, to individual Contracts within the package. Price reductions or discounts shall be submitted in accordance with ITT, provided the Tenders for all contracts are submitted and opened at the same time. • All duties, taxes including GST, royalties, cess and other levies payable by the Contractor under the Contract, or for any other cause (including standard specifications), as of the date 28 days prior to the deadline for submission of Tenders, shall be included in the percentage quoted in the Price Schedule and the total Tender Price submitted by the Tenderer. GST shall be paid by the Tenderer as applicable in accordance with the prevailing rules of Government of India. • Tenderers should note that during the progress of the works, the foreign currency requirements of the outstanding balance of the Contract Price may be adjusted by agreement between the Employer and the Contractor in order to reflect any changes in foreign currency requirements for the Contract, in accordance with Sub-Clause 14/ITT (Currencies of Bid and Payment) of the Conditions of Contract. Any such adjustment shall be affected by comparing the percentages quoted in the Tender with the amounts already used in the Works and the Contractor's future needs for imported items. • Tenderer should note that non-submission of the Letter of Price Tender (LPB) and/or Summary sheet of Price Schedule by the Tenderer shall result in summary rejection of his Tender. • Online alternative Price Tender corresponding to the alternative Technical Tender, if permissible, in accordance with ITT Clause 14;
<p>13.7</p>	<p>The following para is added:</p> <p>In this tender, the tender security/ EMD has to be paid.</p> <p>The Technical bids along with the Earnest Money Deposit (EMD) i.e., Rs. 26,78,248/- should be paid through e-payment as specified in sub clause 10.1.1 and 13.7 of Section. 2 of ITT in the e-procurement portal only using any of the following four modes:</p> <ul style="list-style-type: none"> • Credit Card. • Direct Debit. • National Electronic Fund Transfer (NEFT). • Over the Counter (OTC). <p>The part of the EMD amount of Rs.1.00 lakh accepted in the form of electronic cash (not through DD/BG) and will be maintained in the Government of Karnataka central pooling account held at ICICI Bank until the contract is closed.</p> <p>The balance required EMD of Rs.25,78,248 to be furnished in the form of Bank Guarantee (BG) of any Nationalized Bank/Scheduled Bank (as per RBI guidelines) payable to – Managing Director/K-RIDE, Bengaluru. The EMD shall have to be valid for 45 days beyond the validity of the tender. The scanned copy of the BG should be uploaded to the tender in the e-procurement platform. The Original Bank Guarantee shall compulsorily be produced & submitted for verification before the opening of the technical bid date and time as specified in e-portal to the concerned JGM/S&T in K-RIDE office. The bidder shall note that the Original Bank Guarantee submitted through post/in person, if it does not reach before the opening of the technical bid date and time as specified in e-portal to the concerned JGM/S&T in K-RIDE office the bid will not be considered for technical evaluation. The bids of the</p>

contractors who have failed to produce and submit the original bank guarantee of earnest money deposit of tender before the opening of the technical bid date and time as specified in e-portal to the concerned **JGM/S&T**, the bids will not be opened/If it is opened by default/manual/electronic error the bid will not be considered for technical evaluation and bid shall be rejected. Non reconciliation of tender earnest money deposit receipt of payment in Government of Karnataka central pooling account held at the ICICI Bank, the tender gets rejected.

Bank Guarantee Format

(a) An unconditional bank guarantee using the Form given in Section 3: Qualification Information and Bidding Forms. The bank guarantee shall be from a bank having minimum net worth of over INR 500 million from the specified banks as under:

- (i) a Scheduled Bank in India, or
- (ii) a Foreign Bank having their operations in India, or
- (iii) a Foreign Bank which do not have operations in India is required to provide a counter-guarantee by State Bank of India,

(b) The Scheduled Bank issuing the Bank Guarantee must be on "Structure Financial Messaging System (SFMS)" platform. A separate advice of the BG shall be invariable be sent by the issuing bank to the Employer's Bank through SFMS and only after this the BG shall become operative and acceptable to the Employer.

Further, the Tender Security in Original form along with a copy of "MT760COV (in case of Bank Guarantee message) / MT767COV (in case of Bank Guarantee amendment message) Report" sent by the BG issuing Bank Sealed in an envelope shall be submitted, as stated in ITT 15.

The Issuing Bank shall send the SFMS to:

Beneficiary: Rail Infrastructure Development Company (Karnataka) Limited (K-RIDE)

Bank Name: Canara Bank

Branch: Prime Corporate Branch

Account No. 0430201012110

IFSC Code: CNRB0002636

The Tender security shall be valid up to 45 days beyond tender validity, or up to the date mentioned in the letter of request for extension, if any under ITT 12.

In case the Tenderer has opted for Tender security in the form of an unconditional Bank Guarantee, the Tenderer should upload the scanned copy of Bank Guarantee with the Tender. Non submission of scanned copy of Bank Guarantee with the Tender on e-tendering portal and non-submission of original Bank Guarantee within the specified period shall lead to summary rejection of Tender. The details of the BG, physically submitted should match with the details available in the scanned copy and the data entered during Tender submission time, failing which the Tender will be rejected.

- a. Unless otherwise specified in the BDS, any Tender not accompanied by an enforceable and compliant Tender security as required in accordance with ITT, shall be summarily rejected by the Employer as non-responsive.
- b. The Tender security of the Tenderer who have been determined to be unqualified for opening of their financial Tender shall be returned within 3 working days after the opening of financial Tender. The Tender security of unsuccessful Tenderers shall be returned within 7 working days after issue of LOA to the successful Tenderer.
- c. The Tender security of the unsuccessful Tenderer shall be returned as promptly as possible

SECTION:2: - INSTRUCTIONS TO TENDERERS (ITT)

	<p>once the successful Tenderer has signed the Contract and furnished the required performance security.</p> <p>d. The Tender security may be forfeited:</p> <p>(a) if a Tenderer withdraws its Tender during the period of Tender validity specified by the Tenderer on the Letter of Tenders, except as provided in ITT Clause 12 or</p> <p>(b) if a Tenderer misrepresents or omits the facts in order to influence the procurement process;</p> <p>(c) if the successful Tenderer fails to:</p> <p>(i) sign the Contract in accordance with ITT Clause 28;</p> <p>(ii) furnish a performance security in accordance with ITT 29;</p> <p>(iii) accept the correction of its Tender Price pursuant to ITT 24; or</p> <p>(iv) furnish a domestic preference security if so required.</p> <p>(d) if the undertaking of the affidavit submitted by the Tenderer or its constituents in pursuance to ITT clause 2 or any of the declarations of Letter of Technical Tender or Letter of Price Tender submitted by the Tenderer has been found to be false at any stage during the process of Tender evaluation.</p> <p>e. The Tender Security of a JV/ Consortium shall be in the name of the JV/ Consortium that submits the Tender or the lead member of the JV/Consortium. If the JV/ Consortium has not been legally constituted at the time of Tendering, the Tender Security shall be in the names of all future partners as named in the letter of intent/ of JV/ Consortium mentioned in ITT Clause 2)</p>
<p>14</p>	<p>The following para is added:</p> <p>The Tender, as well as all correspondence and documents relating to the Tender exchanged by the Tenderer and the Employer, shall be written in English. Supporting documents and printed literature that are part of the Tender may be in another language provided they are accompanied by an accurate translation of the relevant passages in English in which case, for purposes of interpretation of the Tender, such translation shall govern</p>
<p>15</p>	<p>The following para is added:</p> <p>Sealing and Marking of Tenders</p> <p>The Tenderer shall submit the technical Tender, Price Tender and the Tender Security/Tender Security Declaration through Karnataka Public Procurement Portal i.e., https://eproc.karnataka.gov.in. The original of the Technical Proposal, which will contain all Forms of Section 3 except Price Schedule Section 9 and all other relevant data specified in the Tender document.</p> <p>The Price Bid, shall be submitted through Karnataka Public Procurement Portal only. This "PRICE BID" will contain only Price Schedule and all other relevant data specified in this Tender document. All forms should be typed on the Tenderer's' letter head as per the exact format of the Forms.</p> <p>The above forms should be scanned and submitted through Karnataka Public Procurement Portal.</p> <p>No details about price proposal shall be disclosed directly or indirectly in the technical proposal failing which the Tender shall be rejected. Only Electronic Tender submission and opening procedure permitted.</p>
<p>19.7</p>	<p>The following para is added:</p> <p>Tender Opening</p> <ul style="list-style-type: none"> • The Employer shall conduct the opening of Technical Tenders through Karnataka Public Procurement Portal i.e., https://eproc.karnataka.gov.in on the date and at the time mentioned.

	<ul style="list-style-type: none"> • The date and time of the opening of Price Tenders will be announced through Karnataka Public Procurement Portal • At the end of the evaluation of the Technical Tenders, the Employer will intimate Tenderers who have submitted substantially responsive technical proposals and who have been determined as being qualified for award to attend the opening of the price Proposals. The date and time, of the opening of Price Tenders will be advised through email/e-procurement. Tenderers shall be given reasonable notice for the opening of Price Tenders. • The Employer will notify Tenderers in writing who have been rejected on the grounds of being substantially non-responsive to the requirements of the Tendering Document and who have been determined as being not qualified as a result of evaluation of technical proposal and their Price Tender shall not be opened. The Tender security of the Tenderers shall be returned as per due process. • The Employer shall conduct the opening of Price Tenders through Karnataka Public Procurement Portal i.e., https://eproc.karnataka.gov.in of all Tenderers who have submitted substantially responsive Technical Tenders and who have been determined qualified as a result of technical evaluation.
23.4	<p>The following para is added:</p> <p>Deviations, Reservations, and Omissions</p> <p>During the evaluation of Tenders, the following definitions apply:</p> <ul style="list-style-type: none"> (a) “Deviation” is a departure from the requirements specified in the Tendering Document; (b) “Reservation” is the setting of limiting conditions or withholding from complete acceptance of the requirements specified in the Tendering Document; and (c) “Omission” is the failure to submit part or all of the information or documentation required in the Tendering Document.
24.3	<p>The following para is added:</p> <p>Nonconformities, Errors, and Omissions</p> <ul style="list-style-type: none"> • Provided that a Tender is substantially responsive, the Employer may waive any nonconformities in the Tender that do not constitute a material deviation, reservation or omission. • Provided that a Tender is substantially responsive, the Employer may request the Tenderer to submit the necessary information or documentation, within a reasonable period of time, to rectify nonmaterial nonconformities in the Tender related to documentation requirements. Requesting information or documentation on such nonconformities shall not be related to any aspect of the price of the Tender. Failure of the Tenderer to comply with the request may result in the rejection of its Tender.
24.4	<p>The following para is added:</p> <p>Correction of Arithmetical Errors and Omissions in Tender and Evaluation of Tender Price</p> <ol style="list-style-type: none"> 1. Provided that the Tender is substantially responsive, the Employer shall correct arithmetical errors and omissions in the Tender and then arrive at the Evaluated Tender Price on the following basis: <ul style="list-style-type: none"> (a) If there is a discrepancy between the price mentioned in the summary sheet of the Price Schedule and the price that is obtained by calculation i.e. addition of each schedule in the summary sheet of Price Schedule, then the quoted amount of each schedule shall prevail and the price shall be corrected accordingly.

	<p>(b) if the amount has been quoted both in words and in figures and there is a discrepancy in such amount, then the lower of the two shall prevail and shall be considered for evaluation of the price of the schedule.</p> <p>(c) If the amount has been quoted either in words or in figures only, then the same shall be considered for evaluation of the price of the schedule.</p> <p>(d) If no amount has been indicated for any particular schedule in words, as well as in figures, irrespective of the fact whether the Tenderer has written or not written, in such cases, the lumpsum amount of the schedule shall be considered as zero and shall be calculated accordingly;</p> <p>(e) if there is an error in a total corresponding to the addition or subtraction of subtotals, the subtotals shall prevail and the total shall be corrected.</p> <p>(f) The amount for each schedule shall first be calculated after applying discount(s) to the Schedule and the net amount shall be rounded off to a Rupee. Thereafter, evaluated price of the schedules shall be added as the sum of amounts in grand summary sheet and sum of evaluated prices of all schedules shall be the overall Evaluated Tender Price.</p> <p>2. If the Tenderer has submitted the lowest evaluated Tender does not accept the correction of errors and omissions as per above provisions, its Tender shall be disqualified and its Tender security shall be forfeited or its Tender-Securing Declaration executed.</p>
25.6	<p>The following para is added:</p> <p>Conversion to Single Currency</p> <p>For evaluation and comparison purposes the currencies of the Tender shall be converted into Indian Rupees as stated in BDS.</p> <p>An Abnormally Low Tender is one in which the Tender price, in combination with other elements of the Tender, appears so low that it raises material concerns as to the capability of the Tenderer to perform the contract at the offered price. The Employer may in such cases seek written clarifications from the Tenderer, including detailed price analysis of its Tender price in relation to scope, schedule, allocation of risks and responsibilities, and any other requirements of the Tender document. If, after evaluating the price analyses, the Employer determines that the Tenderer has substantially failed to demonstrate its capability to deliver the contract at the offered price, the Employer may reject the Tender/ proposal.</p> <p>Additional Performance Security in case of abnormally low Tenders will have to be submitted.</p> <p>The calculation sheet is as below:</p> <p>If the bid, which results in the lowest Evaluated Bid Price is substantially on lower side and/or seriously unbalanced in the opinion of the Employer as per criteria defined below, the Employer may require the bidder to submit additional performance security as under:-</p> <p>a) If overall price quoted by the L1 bidder is below the engineer's estimated price by more than 10% and the difference between overall price quoted by the L1 and L2 is more than 5% of the estimated price, then the bid price of L1 bidder shall be treated as substantially on lower side and such bidder shall be bound to furnish additional performance security equal to the (0.9x engineer's estimated price – L1 price) or (0.95 x L2 price – L1 price) whichever is lower, on this account. Example below demonstrates the method of calculation to arrive at additional performance security:</p> <p>Suppose overall price quoted by the L1 bidder is 17% below the estimated price and the overall price quoted by L2 bidder is 8% below the estimated price. In this case the overall price quoted by the L1 bidder is lower by more than 10% of the estimated price and also the difference</p>

	<p>between overall price quoted by the L2 and L1 bidder is more than 5% of the estimated price, hence the L1 bidder shall be required to furnish additional performance security for an amount equal to $\{0.9 \times \text{engineer's estimated price} - (1-17/100) \times \text{engineer's estimated price}\} = \{0.07 \times \text{engineer's estimated price}\} = 7\%$ of engineer's estimated price or $\{0.95 \times (1-8/100) \times \text{engineer's estimated price} - (1-17/100) \times \text{engineer's estimated price}\} = \{0.044 \times \text{engineer's estimated price}\} = 4.4\%$ of engineer's estimated price; whichever is lower.</p> <p>As per the above L1 bidder shall be required to submit additional performance security of 4.4% of engineer's estimated price.</p> <p>b) If for any bill/ schedule of quantities % age above or below quoted by the bidder on the estimated price is beyond 15% below the overall % age difference between the quoted contract price and the engineers estimated price, then the price for that particular schedule shall be treated as seriously unbalanced and bidder shall be bound to furnish additional performance security for such unbalanced price. Example below demonstrates the method of calculation to arrive at unbalanced price and additional performance security:</p> <p>Suppose for the L1 bidder overall % age difference between quoted contract price and the engineers estimated price;</p> <p>$(\text{Overall contract price} - \text{Overall estimated price}) \times 100 \div \text{overall estimated price} = + 4 \%$</p> <p>Maximum % age below permitted over estimated price of any bill / schedule in this case = +4 – 15 = -11%</p> <p>Suppose for the L1 bidder has quoted 20% below estimated price then the pricing shall be treated as unbalanced and the bidder shall be required to furnish additional performance security for an amount equal to (20 – 11) % of the estimated price..</p>
26.2	<p>The following para is added:</p> <p>Award Criteria</p> <ul style="list-style-type: none"> • The Employer shall award the Contract to the Tenderer whose Tender is substantially responsive to the Tendering Document, provided further that the Tenderer is determined to be qualified to perform the Contract satisfactorily and whose offer has been determined to be the lowest evaluated subject to ITT below. In case of more than one Tenders are evaluated to be lowest, Contract shall be awarded to the Tenderer having higher average annual construction turnover (calculated as total certified payments received for contracts in progress or completed) in equivalent INR within the last Two financial years. • The Employer has the right to review at any time prior to award of contract that the qualification criteria as specified in Section-3: Qualification Information and Bidding Forms are still being met by the Tenderer whose offer has been determined to be the lowest evaluated Tender. A Tender shall be rejected if the qualification criteria as specified in Section-3: Qualification Information and Bidding Forms are no longer met by the Tenderer whose offer has been determined to be the lowest evaluated Tender. In this event the Employer shall proceed to the next lowest evaluated Tender to make a similar reassessment of that Tenderer's capabilities to perform satisfactorily.
29.5	<p>The following para is added:</p> <p>Performance Security</p> <p>The successful Tenderers shall have to submit a Performance Guarantee (PG) Within twenty (20) days from the date of issue of Letter of Acceptance (LOA). Extension of time for submission of PG beyond 20 days up to 60 days from the date of issue of LOA may be given by the authority who is competent to sign the contract agreement. However, a penal interest of 12% of per annum shall be charged for the delay beyond 20 days, i.e. From 21nd day after the date of issue of LOA. Further if the 60th day happens to be declared holiday in the office of K-RIDE, submission of PG can be accepted</p>

SECTION:2: - INSTRUCTIONS TO TENDERERS (ITT)

	<p>on the next working day.</p> <p>In all other cases if the contractor fails to submit the requisite PG even after 60 days from the date of issue of LOA, the contract is liable to be terminate. In case contract is terminated K-RIDE shall be entitled to forfeit the Tender security and other dues payable against to the contract. In case the tenderer has not submitted by security on the strength of their registration as a start-up recognized by the Department of Industrial Policy and Promotion (DIPP) under Ministry of Commerce and Industry, DIPP shall be informed to this effect. The failed contractor shall be debarred from participating in re-tender for that work.</p> <p>Failure of the successful Tenderer to submit the above-mentioned Performance Security or to sign the Contract Agreement shall constitute sufficient grounds for the annulment of the award and forfeiture of the Tender security or execution of the Tender-Securing Declaration.</p> <p>The above provision shall also not apply to the furnishing of a Domestic Preference Security, if so required.</p>
<p>New Clause-1</p>	<p>LITIGATION HISTORY: (Please see Annexure Tendering Forms).</p> <p>The Tenderer/Tenderers should provide accurate information on any litigation or arbitration resulting from contracts completed or under its execution over the last five years as on date of submission of this tender.</p> <p>If the litigation started by the Tenderer without recourse to measures of Dispute Resolution and Arbitration as provided in the Contract or the litigation in respect of challenge of award of Arbitration by the Tenderer, will be treated as Litigation case indulged by the Tenderer for this Para of Litigation History. A consistent history of awards against the Applicant or any partner of a joint venture may result in failure of the application.</p> <p>Note: Tenderers including each of the partners of a Joint Venture, should provide information on any history of litigation or Arbitration resulting from contracts executed in the last 5 years as on date of submission of this tender. A separate sheet should be used for each partner of a Joint Venture</p>
<p>New Clause-2</p>	<p>Jurisdiction of Courts</p> <p>The Tendering process shall be governed by and construed in accordance with the laws of India and the Courts as indicated in Tender Data Sheet shall have exclusive jurisdiction over all the disputes/issues arising under, pursuant to and/ or in connection with the Tendering process. The Jurisdiction of Courts is Bengaluru, Karnataka</p>

SECTION-3

QUALIFICATION INFORMATION/BIDDING FORMS

INDEX

SECTION-3: QUALIFICATION INFORMATION/BIDDING FORMS

This Section contains the forms which are to be completed by the Bidder and to be submitted as part of this Bid.

Sl. No.	Description	Form Number/ Para No.	Page No.
	A) Qualification Information/Bidding Forms		
1.	Legal status of Tenderer	Para No. 1.1	45
2.	Executed and Payment Received statement for 5 Years	Para No. 1.2	45
3.	Similar Work Experience	Para No. 1.3	46
4.	Quantities of Work executed in Last 5 years	Para No. 1.4	47
5.	Information on Works (Existing, Ongoing and Works for which Tenders already submitted)	Para No. 1.5	48
6.	Availability of Plant and Equipment Details	Para No. 1.6	49
7.	Reports of Financial Standing (Profit and Loss Statements)	Para No. 1.7	49
8.	Qualification and Experience of Key Personnel	Para No. 1.8	49
9.	Tenderers bankers Details	Para No. 1.9	49
10.	Evidence of access to Financial Resources	Para No. 1.10	49
11.	Proposed Subcontracting components	Para No. 1.11	49
12.	Information on Litigation History	Para No. 1.12	50
13.	Proposed Methodology and Program of construction	Para No. 1.13	51
	B) Additional Qualification Information/Bidding Forms		
14.	Letter of Technical Bid	Form PS 1	52-54
15.	Letter of Price Bid	Form PS 2	55
16.	Format for Affidavit (along with Bid)	Form PS 3	56-58
17.	Format of Bid Security (Bank Guarantee)	Form BGF	59
18.	Letter of participation from Each partner of Joint Venture (JV)/ Consortium	Form JV/Consortium/1	60-61
19.	Power of attorney for authorized signatory of Joint Venture (JV)/ Consortium partners	Form JV/Consortium/2	62
20.	Power of attorney to Lead partner of joint venture (JV)/ Consortium	Form JV/Consortium/3	63-64
21.	Draft Joint Venture Agreement	Form JV/Consortium/4	65-67
	Bidder Qualification		
22.	Bidder's Information Sheet	Form ELI - 1	68
23.	JV/Consortium Information Sheet	Form ELI - 2	69
24.	Financial Situation	Form FIN - 1	70-71
25.	Annual Construction Turnover	Form FIN - 2	72
26.	Current Contract Commitment	Form FIN - 3	73
27.	Deleted	Form No 1	74
28.	Checklist for clauses pertaining to Summary Rejection of bid	Form No 2	75
29.	Format for certificate to be submitted by bidder along with the bid	Form 3 C1	76
30.	Format for certificate to be submitted by Bidder along with the bid for subcontracting	Form 3 C2	77
31.	Key Personnel for the work	Form 5	78-79
32.	Format of Curriculum Vitae (cv) for proposed key professional staff	Form 6	80
33.	Undertaking from specialist sub-contractor	Form CL-2	81
34.	Availability of Financial Resources	Form CL-3	82
35.	Evidence of Availability of Credit Line Financial Resources	Form CL-4	83
36.	Work Experience Certificate	Form EXP-1	84-85

A) QUALIFICATION INFORMATION/BIDDING FORMS

1. QUALIFICATION INFORMATION

The information to be filled in by the Tenderer hereunder will be used for purposes of computing Tender capacity as provided for in Clause 2 of the Instructions to Tenderers. This information will not be incorporated in the Contract.

1.1. Constitution or legal status of Tenderer

Place of Registration: _____ [Attach copy]

Principal place of business: _____ [Attach Copy]

1.2. Total value of construction works executed and payments received in the preceding five Financial Years. (Rs. In Crores) (attach certificate from Statutory Auditors)

2017-2018: -----

2018-2019: -----

2019-2020: -----

2020-2021: -----

2021-2022: -----

K-RIDE

1.3. Work performed as Contractor (in the same name) on works of similar nature over during the five financial years specified in 1.2 above.

Project Name	Name of Employer	Description of Work	Contract Number	Value of contract Rs. Cr.	Date of Issue of work order	Specified period of completion	Actual date of completion	If partner in a JV/ Consortium, specify participation in total contract amount	Remarks explaining reasons for delay in completion of work
1	2	3	4	5	6	7	8	9	10

Note:

- (1) If the qualifying work of similar nature is done by a joint venture/consortium, then Value shall be considered as per percentage participation by the member(s) in that joint venture/consortium.
- (2) Value of *similar nature of work completed shall be updated up to date of submission as per table given below:

Financial year	2017-18	2018-19	2019-20	2020-21	2021-22
Indian Currency					
Foreign Currency					

- (1) For completed works, the value of work done shall be updated to current FY 2022-23 price level assuming 10% inflation for Indian rupees every year or part thereof up to the month previous to the Bid submission month. Credentials if submitted in foreign currency shall be converted into Indian currency i.e., Indian Rupee as under: Bids will be compared in Indian Rupees only. The exchange rate of foreign currency shall be applicable 28 days before the tender submission date. For conversion of foreign currency to Indian Rupee exchange rates published by Financial Benchmarks Private limited (www.fbil.org.in) 28 days before the date of bid submittal will be considered. In case the particular day happens to be a holiday the exchange rate published on the next working day will be considered. In case of works in foreign currency the effect of inflation is considered as included, as the exchange rate prevailing 28 days before tender submission is being considered for conversion to Indian Rupees,

The bidder shall attach a copy of the Certificate(s) issued by the employer in support of the information being furnished in the above form, failing which the claim of the bidder shall be liable to be rejected (in case of experience as a sub-contractor, the employer shall be the owner of the Project who has engaged the main Contractor).

SEAL AND SIGNATURE

1.4. Quantities of work executed as contractor (in the same name) during the last five years.

Year	Name of Work	Name of Employer	Quantity of work performed (As mentioned in Qualification of the Tenderer Clause 3.2)	Remarks (Indicate contract reference Contract No., Award Date, Completion date, Role in contract, total contract amount, JV participation proportion)
			Commissioning of signaling works (EI/RRRI/PI/Auto block signaling) either outdoor or indoor or both	
2017-18				
2018-19				
2019-20				
2020-21				
2021-22				

Note:

- 1) Copy of Certificate(s) issued by the employer in support of the information being furnished above, shall be attached with each respective form, as per detailed requirements indicated in clause 3.2 (c) of Section 2 failing which the claim of the bidder shall be liable to be rejected (in case of experience as a sub-contractor, the employer shall be the owner of the Project who has engaged the main Contractor).

SEAL AND SIGNATURE

1.5. Information on works for which Tenders have been submitted and works which are yet to be completed as on the date of this Tender.

(A) Existing commitments and on-going works:

Description of Work	Place & State	Contract No. & Date	Name and Address of Employer	Value of Contract (Rs. In Crores)	Stipulated period of completion	Value of works remaining to be completed (Rs. In Crores) (Attach certificate from Engineer in charge)	Anticipated date of completion
(1)	(2)	(3)	(4)	(5)	(6)	(7)	(8)

(B) Works for which Tenders already submitted:

Description of Work	Place & State	Name and Address of Employer	Estimated value of works (Rs. In Crores)	Stipulated period of completion	Date when decision is expected	Remarks if any
(1)	(2)	(3)	(4)	(5)	(6)	(7)

- 1.6. The following items of equipment are considered essential for successfully carrying out the works. The Tenderer should furnish all the information listed below. (The item of the equipment required nos and capacity should match with those specified in ITT clause 3.3(a))

Item of Equipment	Requirement			Owned and available nos/Age/Capacity/Condition	Remarks (The details of hired/leased equipment details to be indicated)
	Nos	Capacity	Owned		

- 1.7. Reports on the financial standing of the tenderer, such as profit and loss statements and auditor's reports for the last five years;
- 1.8. Qualification and experience of the key technical and management personnel in permanent employment with the tenderer and those that are proposed to be deployed on this contract, if awarded.
- 1.9. Name, address, and telephone, telex, and fax numbers of the Tenderers' bankers who may provide references if contacted by the Employer.
- 1.10. Evidence of access to financial resources to meet the qualification requirement specified in ITT Clause 3.3 (b): Cash in hand, Letter of Credit etc. List them and attach certificate from the Banker in the suggested format given in Section 3, Form No.CL3 & CL4.
- 1.11. Proposals for subcontracting components of works amounting to more than 20% of the contract price.

Item of Work	Value of Sub-Contract	Identified Sub-Contractor (Name and Address)	Experience of similar works (Attach Certificates from the respective Employers)	Remarks (Undertaking from Specialist subcontractors to be provided as per Form CL-2)

1.12. Information on litigations in which the Tenderer is involved:

Litigation History

(This has reference to Eligibility cum Qualification Criteria document.)

Name of Tenderer or member of Joint Venture: -
--

Sl. No.	Name of the Employer/ Client	Name of the work	No. of cases in the work	cause of Litigation/ arbitration/ details of disputes	Year	Litigation/ arbitration initiated by	Award in favor of Tenderer/ Client	Disputed Amount	Remarks showing present status

Note: Tenderers including each of the partners of a Joint Venture, should provide information on any history of litigation or Arbitration resulting from contracts executed in the last 10 years as on date of submission of this tender. A separate sheet should be used for each partner of a Joint Venture

- 1.13. **The proposed methodology and program of construction, backed with equipment planning and deployment, duly supported with broad calculations and quality control procedures proposed to be adopted, justifying their capability of execution and completion of the work as per technical specifications within the stipulated period of completion as per milestones.**

APPROACH & METHODOLOGY PROPOSED FOR PERFORMING THE ASSIGNMENT

Name of Project: “

The approach and methodology will be detailed precisely under the following topics:

1. Understanding of the assignment
2. Work Breakdown structure/ Work plan.
3. Composition of the Team
4. Organizational set up/ Construction methodology for execution of the work as outline in Section 8A
5. Documentation and procedures to be prepared, adopted and furnished to K-RIDE (Rail Infrastructure Company (Karnataka) Limited).
6. Reporting Procedure
7. Sourcing of Material

Note:

- i. **The approach and methodology should be precise and relevant to the assignment. Include Bar charts.**

B) ADDITIONAL QUALIFICATION INFORMATION/BIDDING FORMS

Form: PS1

LETTER OF TECHNICAL BID

(Seperately for each Package)
Date.....

Invitation for Bid No.:.....

To,
.....

We, the undersigned, declare that:

- (a) We have examined and have no reservations to the Bidding Documents, including Addenda issued in accordance with Instructions to Tenderer (ITT);
- (b) We offer to execute the Works in conformity with the Bidding Documents;
- (c) Our bid shall be valid for a period of 180 days from the date fixed for the bid submission deadline in accordance with the Bidding Documents, and it shall remain binding upon us and may be accepted at any time before the expiration of that period;
- (d) If our bid is accepted, we commit to obtain a performance security in accordance with the Bidding Documents;
- (e) If our bid is accepted, we commit to deploy key equipment and key personnel consistent with the requirements stipulated in Section 8A: Works Requirements.
- (f) If our bid is accepted, we commit to submit work method statements for all major activities and get these approved from the engineer prior to commencing work on such activities. We also understand that the work shall be executed as per the approved method statements and KEY DATES without any deviations and delay in completion.
- (g) We, including any subcontractors or suppliers for any part of the contract, do not have any conflict of interest in accordance with ITT clause 2.4;
- (h) We declare that we are not participating, as a Bidder or as a subcontractor, in more than one bid in this bidding process in accordance with ITT clause 2.2, other than alternative offers submitted in accordance with ITT clause 14;

- (i) We declare that we are not liable to be disqualified in Accordance with ITT clause 2.5, and we are enclosing the affidavit for the same as per the Performa given in the bid document.
- (j) We understand that this bid, together with your written acceptance thereof included in your notification of award, shall constitute a binding contract between us, until a formal contract is prepared and executed; and
- (k) We have not made any deviations from the requirement of the bidding document and we have also not made any tampering or changes in the bidding documents on which the bid is being submitted and if any tampering or changes are detected at any stage, we understand the bid will invite summary rejection and invocation of bid security declaration, the contract will be liable to be terminated along with forfeiture of performance security, even if LOA has been issued.
- (l) We understand that we will be considered for participating for which we have submitted the bid security(ies) declaration form and we will be considered for award, subject to fulfilling the eligibility criteria as given in bidding document;
- (m) If our bid is accepted, we opt to take payment into the bank account, nominated by us.
- (n) We declare that the submission of this bid confirms that no agent, middleman or any intermediary has been, or will be engaged to provide any services or any other item of work related to the award and performance of this contract. We further confirm and declare that no agency commission or any payment which may be construed as an agency commission has been, or will be, paid and that the bid price does not include any such amount. We acknowledge the right of the Employer, if he finds to the contrary, to declare our bid to be noncompliant and if the contract has been awarded to declare the contract null and void
- (o) We understand that you are not bound to accept the lowest evaluated bid or any other bid that you may receive.
- (p) A Power of Attorney to sign and submit this letter is attached.
- (q) Having inspected the site, examined the complete bid document including Employer's requirements, Conditions of Contract, Special Conditions of Contract, particular conditions of Contract, Technical Specifications, Safety, Health & Environment (SHE) manual, Eligibility Cum Qualification Criteria, Instructions to Bidder and Addenda/Corrigendum etc., thereto (if any) for above mentioned work and prepared the bid entirely in accordance with all the requirements of the bid document and agree entirely with them.
- (r) We here by confirm that we have visited the sites of work and have become conversant with the local conditions of working.
- (s) For the purpose of your evaluation, study, review and decision-making we are ready to let you inspect our business premises / site, etc.
- (t) We authorize K-RIDE or any of their authorized representative to approach, enquire, verify and check the matter furnished in our submission with the concerned client / owner of the Project / Contract and the concerned Banker of reference provided by us.

- (u) We undertake to hold in confidence all documents and information whether Technical or Commercial supplied to us at any time by or on behalf of K-RIDE in connection with this bid and without your written authority or as otherwise required by law not to publish or otherwise disclose the same.
- (v) If our bid is accepted, we agree to establish our project office in Bangalore.
- (w) We have submitted the Statement of Integrity, Eligibility, Social, and Environmental Responsibility signed and abide by the same.
- (x) We understand that this Bid shall be governed by and construed in all respects according to the laws for the time being force in India. The courts at Bangalore will have exclusive jurisdiction in the matter.
- (y) We undertake that, in competing for (and, if the award is made to us, in executing) the above contract, we will strictly observe the laws against fraud and corruption in force in India namely "Prevention of Corruption Act 1988".

We hereby confirm that this Tender complies with the Tender validity and Earnest money deposit required by the Tender documents.

- (z) We confirm and declare that by virtue of our signature below, to the best of knowledge and belief that the information provided by us as required in this Bid Document, all supporting and explanatory information is truthful and exact.

Name.....
 In the capacity
 of.....

Signed

Duly authorized to sign the Bid for and on behalf of

Date

(SEAL AND SIGNATURE OF THE BIDDER)

LETTER OF PRICE BID

(To be separately given for each package on the Letter head of the Firm)

Date.....

Invitation for Bid No.....

To:.....

We, the undersigned, declare that:

- (a) We have examined and have no reservations to the Bidding Documents, including Addenda issued in accordance with Instructions to Bidders (ITB) 8;
- (b) We offer to execute the Work in conformity with the Bidding Documents;
- (c) The total price of our Bid, indicated in the Price Bid on Karnataka e-procurement portal
- (d) We understand that this bid, together with your written acceptance thereof included in your notification of award, shall constitute a binding contract between us, until a formal contract is prepared and executed; and
- (e) We have not made any deviations from the requirement of the bidding document and we have also not made any tampering or changes in the bidding documents on which the bid is being submitted and if any tampering or changes are detected at any stage, we understand the bid will invite summary rejection and forfeiture of bid security declaration form/the contract will be liable to be terminated along with forfeiture of performance security, even if LOA has been issued.
- (f) We understand that you are not bound to accept the lowest evaluated bid or any other bid that you may receive.

Name

In the capacity of

Signed

Duly authorized to sign the Bid for and on behalf of

Date

Seal

Form: PS 3**FORMAT FOR AFFIDAVIT TO BE SUBMITTED BY BIDDER ALONGWITH THE BID**

(To be separately given for each package)

*(To be executed in presence of Public Notary on non-judicial stamp paper of the appropriate value in accordance with relevant stamp Act. The stamp paper has to be in the name of the bidder) ***

I **(Name and designation)** **..... appointed as the attorney/authorized signatory of the bidder (including its constituents), M/s. _____ (hereinafter called the bidder) for the purpose of the Bid for the work of _____ as per the bid No. _____ of K-RIDE, do hereby solemnly affirm and state on behalf of the bidder including its constituents as under:

- *1. That the bidder or any of its constituents has not been Blacklisted/ banned for business dealings for all Government Departments or by Ministry of Railways or by K-RIDE at any time and/or no such blacklisting is in force as on the deadline for submission of bids.
- *2. That none of the previous contracts of the bidder or any of its constituents had been terminated/rescinded for Contractor's failure or part terminated for its failure as a JV/ Consortium partner with forfeiture of its full Performance Security, by Rail Infrastructure Development Company (Karnataka) Ltd. during the period of last 3 years before the deadline for submission of bids.

(Add Proviso of Clause 2, (ITT) suitably, if any Contract was so terminated).

- *3. The bidder or any of its constituents has not been imposed liquidated damages of 5% or more of contract value by any Government Department or by Ministry of Railways or by K-RIDE due to delay in the implementation of any previous contract (either in the capacity of a single entity or as constituent of any other JV/ Consortium) within the period of last 2 years before the deadline for submission of bid [2 years shall be reckoned from the date on which imposed L.D. has exceeded 5% of the contract price] and there are no such accrued delay damages which has not been fully recovered before the deadline for submission of bids on account of contractor's request for deferring recovery to maintain cash flow and K-RIDE has acceded to the same in the interest of the project and the work under the previous contract in question has been completed before the deadline for submission of bid, unless imposition of such delay damages has been set aside by the Competent Authority.
4. That the Bidder or any of its constituents is neither Bankrupt/Insolvent nor is in the process of winding-up nor is such a case pending before any Court on the deadline of submission of the bid.
- *5. That the name of the Bidder or any of its constituents is not on the list of "Poor Performer" of any Government Department or by Ministry of Railways or by K-RIDE as on the deadline for submission of bid.
6. We declare that the bidder or any of its constituents have not either changed their name or created a new business entity. Consequent to having been banned business dealings for specified period which is not over or suspended business dealings or having been declared as poor performer.

7. We declare and certify that balance sheets for last five financial years including that for the latest concluded financial year are being submitted.

OR

We declare and certify that balance sheet for the latest concluded financial year has not been finalized till date and that is why we are furnishing financial data for last five financial years ignoring the latest concluded financial year.

*(# - Delete whichever is not applicable) **.*

8. We declare and certify that we have not made any misleading or false representation in the forms, statements and attachments in proof of the qualification requirements.
9. We declare that the information and documents submitted along with the bid by us are correct and we are fully responsible for the correctness of the information and documents, submitted by us.
10. We understand that in case we cease to fulfil the requirements of qualifying and eligibility criteria at any time after opening of bids and till finalization of bids, it will be our bounden duty to inform the Employer of our changed status immediately and in case of our failure to do so, our bid shall be rejected and bid security declaration form shall be forfeited. In case such failure comes to the notice of Employer at any time after award of the contract, it will lead to termination of the contract and forfeiture of Bid or Performance Security. We shall also be liable for Banning of Business dealings up to a period of five years.
11. We understand that if the contents of the affidavit are found to be false at any stage during bid evaluation, it will lead to rejection of our bid and forfeiture of the bid security. Further, we ***[insert name of the bidder]*** ** _____ and all our constituents understand that we shall be liable for banning of business dealings up to a period of five years.
12. We declare and certify that we have not made any misleading or false representation in the forms, statements and attachments in proof of the qualification requirements.
13. We also understand that our offer will be evaluated based on the documents/credentials submitted alongwith the offer and same shall be binding upon us.
14. We declare that the information and the document submitted along with the tender by us are correct and we are fully responsible for the correctness of the information and documents, submitted by us.
15. We undersigned that if the certificate regarding Eligibility Criteria submitted by us are found to be forged/false or incorrect at any time during process for evaluation of tenders, it shall lead to forfeiture of the tender EMD besides banning of business for five years in K-RIDE. Further, we (Insert name of the Tenderer)** and all our constituents understand that our offer shall be summarily rejected.
16. We also understand that if the certificate submitted by us are found to be false/forged or incorrect at any time after the award of contract, it will lead to termination of the contract, along with forfeiture of EMD/SD and performance guarantee besides any other action provided in the contract including banning of business for five year in K-RIDE.

(SEAL AND SIGNATURE OF THE BIDDER)

Verification:

We above named tenderer do hereby solemnly affirm and verify that the contents of our above affidavit are true and correct. Nothing has been concealed and no part of it is false.

(SEAL AND SIGNATURE OF THE BIDDER)

*Modify the contents wherever necessary, in terms of sub-clause 2 ITT.

** The contents in Italics are only for guidance purpose and details as appropriate, are to be filled in suitably by Bidder.

Attestation before Magistrate/Public Notary

K-RIDE

FORMAT OF BID SECURITY (BANK GUARANTEE)

WHEREAS _____ having its registered office at _____
 _____ (hereinafter called the –Bidder) has submitted his bid dated _____ for the
 work “**Signaling Outdoor and indoor works with Distributed Electronic interlocking (EI) at Yesvantpur Jn. in
 connection with doubling of Yesvantpur-Channasandra section of Bangalore Division**” (hereinafter called “the
 Works”) KNOW ALL PEOPLE by these presents that we,
 _____ having its registered office at
 _____ (hereinafter called the Bank) are bound unto the Managing
 Director, Rail Infrastructure Development Company Karnataka Ltd (**K-RIDE**), Bangalore.(hereinafter called “the
 Employer”) in the sum of Rs. _____ (Rupees _____) for which payment well and
 truly to be
 made to the said Employer the Bank binds itself, his successors and assigns by these presents;
 SEALED with the Common Seal of the said Bank this day _____.

THE CONDITIONS OF THIS OBLIGATION ARE:

- (1) If after Bid opening the Bidder withdraws his Bid during the period of Bids validity specified in the Form of Bid.
 OR
 (2) If the Bidder having been notified of the acceptance of his Bid by the Employer during the period of
 Bid Validity.
- a. Fails or confuses to execute the form of Agreement in accordance with the instructions to Bidders, if
 required; or
 - b. Fails or refuse to furnish the Performance Security, in accordance with the instruction to
 Bidders; or
 - c. Does not accept the correction of the Bid Price pursuant to clause 24

We undertake to pay to the Employer up to the above amount upon receipt of his first written demand,
 without the Employer having to substantiate his demand, provided that in his demand the Employer will
 note that the amount claimed by him is due to him owing to the conditions of one or both of the two
 conditions, specifying the occurred condition or conditions.

This Guarantee will remain in force up to and including the date 225 days after the deadline for submission
 of bids as such deadline is stated in the instructions to Bidders of as it may be extended by the Employer,
 notice of which extension(s) to the Bank is hereby waived. Any demand in respect of this Guarantee should reach
 the Bank not later than the above date

DATE _____ SIGNATURE OF THE BANK _____

WITNESS _____

SEAL _____

Form: JV/Consortium/1

**PRO-FORMA LETTER OF PARTICIPATION FROM EACH PARTNER OF JOINT VENTURE (JV)/
CONSORTIUM**

(On each Firm's Letter Head)

No.....

Dated:.....

From,

.....
.....

To,

The General Manager,
Rail Infrastructure Development Company (Karnataka) Limited,
"Samparka Soudha", 1st Floor,
B.E.P Premises (Opp. Orion Mall),
Rajajinagar 1st Block,
Bangalore - 560 010.

Gentlemen,

Re: ... "[Insert name of work]"

Ref: Your notice for Invitation for Bid (IFB)

1. We wish to confirm that our company/firm (delete as appropriate) has formed a Joint Venture/ Consortium by name of with for the purposes associated with IFB referred to above.
(Members who are not the lead partner of the JV/ Consortium should add the following paragraph) *
2. 'The JV/ Consortium is led by ... whom we hereby authorize to act on our behalf for the purposes of submission of Bid for and authorize to incur liabilities and receive instructions for and on behalf of any and all the partners or constituents of the Joint Venture/ Consortium.'

OR

(Member(s) being the lead member of the group should add the following paragraph) *

2. 'In this group we act as leader and, for the purposes of applying for qualification, represent the Joint Venture/ Consortium.'
3. In the event of our group being awarded the contract, we agree to be jointly with..... (names of other members of our JV/ Consortium) and severally liable to the (K-RIDE) Rail Infrastructure Development

Company (Karnataka) Limited, Bangalore, its successors and assigns for all obligations, duties and responsibilities arising from or imposed by the contract subsequently entered into between Rail Infrastructure Development Company (Karnataka) Limited, Bangalore and our JV/ Consortium.

4. *I/We, further agree that entire execution of the contract shall be carried out exclusively through the lead partner.

Yours faithfully,

(Signature)

(Name of Signatory)

(Capacity of Signatory)

Seal

* Delete as applicable

K-RIDE

Form: JV/Consortium/2

**FORMAT FOR POWER OF ATTORNEY FOR AUTHORISED
SIGNATORY OF JOINT VENTURE (JV)/ CONSORTIUM PARTNERS**

POWER OF ATTORNEY

(To be executed on non-judicial stamp paper of the appropriate value in accordance with relevant stamp Act. The stamp paper to be in the name of the company who is issuing the power of Attorney)

Know all men by these presents, we ... do hereby constitute, appoint and authorize Mr/Ms. who is presently employed with us and holding the position ofas our attorney, to do in our name and on our behalf, all such acts, deeds and things necessary in connection with or incidental to our bid for the work of ...Including signing and submission of all documents and providing information/responses to Rail Infrastructure Development Company (Karnataka) Limited, Bangalore, representing us in all matters, dealing with Rail Infrastructure Development Company (Karnataka) Limited, Bangalore, in all matters in connection with our bid for the said project and if successful, till the whole of the bid process.

We hereby agree to ratify all acts, deeds and things lawfully done by our said attorney pursuant to this Power of Attorney and that all acts, deeds and things done by our aforesaid attorney shall and shall always be deemed to have been done by us.

Dated this the day of 20..

(Signature of authorized Signatory)

.....

(Signature and Name in Block letters of Signatory)

Seal of Company

Witness

Witness 1:

Name:

Address:

Occupation:

Witness 2:

Name:

Address:

Occupation:

*Notes:

- i. To be executed by all the partners individually, in case of a Joint Venture/ Consortium.
- ii. The mode of execution of the Power of Attorney should be in accordance with the procedure, if any, laid down by the applicable law and the charter documents of the executant(s) and when it is so required the same should be under common seal affixed in accordance with the required procedure.
- iii. Also wherever required, the executants(s) should submit for verification the extract of the charter documents and documents such as resolution/ power of attorney in favour of the person executing this power of attorney for the designation of power hereunder on behalf of the bidder.

Form: JV/Consortium/3

**FORMAT FOR POWER OF ATTORNEY TO
LEAD PARTNER OF JOINT VENTURE (JV)/ CONSORTIUM**

*(To be executed on non-judicial stamp paper of the appropriate value in accordance with relevant stamp Act.
The stamp paper to be in the name of the company who is issuing the power of Attorney)*

POWER OF ATTORNEY

Whereas Rail Infrastructure Development Company (Karnataka) Limited Bangalore, has invited Bids for the work of

Whereas, the members of the Joint Venture/ Consortium comprising of M/s. ..., M/s., and M/s. are interested in submission of bid for the work of ... *[Insert name of work]* ... in accordance with the terms and conditions contained in the bidding documents.

Whereas, it is necessary for the members of the Joint Venture/ Consortium to designate one of them as the Lead Partner, with all necessary power and authority to do, for and on behalf of the Joint Venture/ Consortium, all acts, deeds and things as may be necessary in connection with the Joint Venture's/ Consortium's bid for the project, as may be necessary in connection the Joint Venture's/ Consortium's bid for the project.

NOW THIS POWER OF ATTORNEY WITNESSETH THAT:

We, M/s., hereby designate M/s., being one of the partners of the Joint Venture/ Consortium, as the lead partner of the Joint Venture/ Consortium, to do on behalf of the Joint Venture/ Consortium, all or any of the acts, deeds or things necessary or incidental to the Joint Venture's/ Consortium's bid for the contract, including submission of bid, participating in conferences, responding to queries, submission of information/ documents and generally to represent the Joint Venture/ Consortium in all its dealings with K-RIDE/ Railway or any other Government Agency or any person, in connection with the contract for the said work until culmination of the process of bidding till the contract agreement is entered into with the Rail Infrastructure Development Company (Karnataka) Limited, Bangalore and thereafter till the expiry of the contract agreement.

We hereby agree to ratify all acts, deeds and things lawfully done by lead member, our said attorney, pursuant to this power of attorney and that all acts deeds and things done by our aforesaid attorney shall and shall always be deemed to have been done by us/ Joint Venture/ Consortium.

Dated this the Day of 202...

.....

(Signature)

.....

(Name in Block letters of Executant)

Seal of Company

Witness 1:

Name:

Address:

Occupation:

Witness 2:

Name:

Address:

Occupation:

Notes:

1. To be executed by all the Partners of the JV/Consortium except the lead Partner.
2. The mode of execution of the Power of Attorney should be in accordance with the procedure, if any, laid down by the applicable law and the charter documents of the executant(s) and when it is so required the same should be under common seal affixed in accordance with the required procedure.

K-RIDE

Form: JV/Consortium/4

DRAFT FORMAT OF JOINT VENTURE/CONSORTIUM AGREEMENT

M/s having its registered office at (hereinafter referred to as)
acting as the Lead Partner of the first part,

and

M/s having its registered office at (here in after referred to as)
.....) in the capacity of a Joint Partner of the other part.

The expressions of and shall wherever the context admit, mean and include their respective legal representatives, successors-in-interest and assigns and shall collectively be referred to as “the Parties” and individually as “the Party”

WHEREAS:

Rail Infrastructure Development Company (Karnataka) Limited (K-RIDE) [hereinafter referred to as “Employer”] has invited bids for ... “[Insert name of work]” Vide LOA No.....awarded contract.

NOW, THEREFORE, THE PARTIES AGREE AS FOLLOWS:

1. The following documents shall be deemed to form and be read and construed as an integral part of this AGREEMENT.
 - i. Notice for Bid, and
 - ii. Bidding document
 - iii. Any Addendum/Corrigendum issued by Rail Infrastructure Development Company (Karnataka) Limited
 - iv. The bid submitted on our behalf jointly by the Lead Partner.
 - v. Letter of Acceptance issued by Rail Infrastructure Development Company (Karnataka) Ltd.
2. The ‘Parties’ have studied the documents and LOA issued to enter into Joint Venture/ Consortium as under and have agreed to participate.
3. M/s shall be the lead member of the JV/ Consortium for all intents and purpose and shall represent the Joint Venture/ Consortium in its dealing with the Employer. For the purpose of execution, the parties agree to nominate as the leader duly authorized to sign and submit all documents and enter into correspondence with the Employer.
4. The ‘Parties’ have resolved that the distribution of share and responsibilities between the JV/Consortium partners is as under
 - (a) Lead Partner Share %
 - Responsibilities**
 - (I) Key Activities and %age execution assigned
 - i.
 - (II) BOQ Schedule/Bill No. and %age execution assigned
 - i.

- ii.
- iii.

(b) Joint Venture/ Consortium Partner Share.....%

Responsibilities

(I) Key Activities and %age execution assigned

- i.

(II) BOQ Schedule/Bill No. and %age execution assigned

- i.
- ii.
- iii.

(c) Joint Venture/ Consortium Partner Share.....%

Responsibilities

(I) Key Activities and %age execution assigned

- i.

(II) BOQ Schedule/Bill No. and %age execution assigned

- i.
- ii.
- iii.

Note: In case any Bill or items of a Bill are proposed to be executed by more than one JV/ Consortium partner then indicate the breakup of that Item/Bill no. for each JV/ Consortium partner.

5. JOINT AND SEVERAL RESPONSIBILITIES

The Parties undertake that they shall be jointly and severally liable to the Employer in the discharge of all the obligations and liabilities as per the contract with the Employer and for the performance of contract awarded to their JV/Consortium.

6. ASSIGNMENT AND THIRD PARTIES

The parties shall co-operate throughout the entire period of this AGREEMENT on the basis of exclusivity and neither of the Parties shall make arrangement or enter into agreement either directly or indirectly with any other party or group of parties on matters relating to the Project except with prior written consent of the other party and the Employer.

7. EXECUTIVE AUTHORITY

The said Joint Venture/ Consortium through its authorized representative shall receive instructions, payments from the Employer. The management structure for the project shall be prepared by mutual consultations to enable completion of project to quality requirements within permitted cost and time.

8. GUARANTEES AND BONDS

Performance Security and other Securities of a JV/ Consortium shall be in the name of the JV/ Consortium that submits the bid.

9. BID SUBMISSION

Each Party shall bear its own cost and expenses for preparation and submission of the bid and all costs until conclusion of a contract with the Employer for the Project. Common expenses shall be shared by both the parties in the ratio of their actual participation.

10. INDEMNITY

Each party hereto agrees to indemnify the other party against its respective parts in case of breach/default of the respective party of the contract works of any liabilities sustained by the Joint Venture/ Consortium.

11. For the execution of the respective portions of works, the parties shall make their own arrangements to bring the required finance, plants and equipment, materials, manpower and other resources.

12. DOCUMENTS & CONFIDENTIALITY

Each Party shall maintain in confidence and not use for any purpose related to the Project all commercial and technical information received or generated in the course of preparation and submission of the bid.

13. ARBITRATION

Any dispute, controversy or claim arising out of or relating to this agreement shall be settled in the first instance amicably between the parties. If an amicable settlement cannot be reached as above, it will be settled by arbitration in accordance with the Indian Arbitration and Conciliation Act 1996 or any amendments thereof. The venue of the arbitration shall be Bangalore.

14. VALIDITY

This Agreement shall remain in force till the defect liability period is over and Securities are released.

15. This AGREEMENT is drawn in number of copies with equal legal strength and status. One copy is held by M/s and the other by M/s. &M/s and a copy submitted with the Bid.

16. This AGREEMENT shall be construed under the laws of India.

17. NOTICES BETWEEN JVI CONSORTIUM PARTNERS

Notices shall be given in writing by fax confirmed by registered mail or commercial courier to the following fax numbers and addresses:

Lead Partner	Other Partner
.....
.....
(Name & Address)	(Name & Address)

IN WITNESS WHEREOF THE PARTIES, have executed this AGREEMENT the day, month and year first before written.

M/s.....	M/s.....
.....
(Seal)	(Seal)

Witness
 1.....(Name & Address)
 2..... (Name & Address)

Bidders Qualification

To establish its qualifications to perform the contract in accordance with Section 2 (Qualification Information) the Bidder shall provide the information requested in the corresponding Information Sheets included hereunder.

To establish its qualifications to perform the contract in accordance with Section 2 (Qualification Criteria) the Bidder shall provide the information requested in the corresponding Information Sheets included hereunder.

Form ELI - 1: Bidder's Information Sheet

Bidder's Information	
Bidder's legal name	
Bidder's country of constitution	
Bidder's year of constitution	
Bidder's legal address in country of constitution	
Bidder's authorized representative (name, address, telephone numbers, fax numbers, e-mail address)	

The bidder shall attach copies of the following original documents with the form:

1. In case of single entity, articles of incorporation or constitution of the legal entity named above, in accordance with ITT clause 2.
2. Authorization to represent the firm or JV/ Consortium named in above, in accordance with ITT clause 14.
3. In case of JV/ Consortium, JV/ Consortium agreement, in accordance with ITT clause 2.

SEAL AND SIGNATURE

Form ELI - 2: JV/ Consortium Information Sheet

Each member of a JV/ Consortium must fill in this form separately

JV / Consortium Information	
Bidder's legal name	
JV/ Consortium Partner's legal name	
JV/ Consortium Partner's country of constitution	
JV/ Consortium Partner's year of constitution	
JV/ Consortium Partner's legal address in country of constitution	
JV/ Consortium Partner's authorized representative information (name, address, telephone numbers, fax numbers, e-mail address)	
Bidder's Bank Details: (a) Name of the Bank and branch: (b) Account Number: (c) IFSC code: (d) Bank's Contact Number and Fax Number: (e) PAN: (f) GST Registration No:	

The bidder shall attach copies of the following original documents with the form:

1. Articles of incorporation or constitution of the legal entity named above, in accordance with ITT clause 2.
2. Authorization to represent the firm named above, in accordance with ITT clause 14.

Note: Following needs to be submitted by the bidder;

- (a) Affidavit in case of Proprietary firm.
- (b) Partnership Deed in case of partnership firm.
- (c) Memorandum & Article of Association in case of Public/Private limited company.
- (d) Authorization/POA in favour of authorised signatory of bidder to sign the bid.

SEAL AND SIGNATURE

Form FIN-1: Financial Situation

(Each Bidder or each member of a JV/Consortium must fill in this form separately)

NAME OF BIDDER/JV/CONSORTIUM PARTNER

	Financial Data for Last 5 Years [Indian National Rupees]				
	Year 1:	Year 2:	Year 3:	Year 4:	Year 5:
1. Total Assets					
2. Current Assets					
3. Total Liabilities					
Current Liabilities					
5. Net Worth [= 1 – 3]					
6. Working Capital [= 2 - 4]					
7. Profit Before Tax (PBT)					

1. The bidder shall attach copies of the following original documents with the form

Copies of the audited balance sheets, including all related notes, and income statements for the last five years, as indicated above, complying with the following conditions.

- i. All such documents reflect the financial situation of the Bidder or partner to a JV/ Consortium, and not sister or parent companies.
- ii. Historic financial statements must be audited by a certified accountant.
- iii. Historic financial statements must be complete, including all notes to the financial statements.
- iv. Historic financial statements must correspond to accounting periods already completed and audited (no statements for partial periods shall be requested or accepted).

2. Contents of this form should be certified by a Statutory Auditor

- i. In the event that the audited accounts for the latest concluded Financial Year are not available, the Bidder shall furnish information pertaining to the last five financial years and provisional balance sheet for latest year. In case, the bidder submits audited financial information for the last six or more years, only the figures for the latest five years shall be considered for evaluation.
- ii. Financial data for last five financial years has to be submitted by the bidder along with audited balance sheets. The financial information of the Bidder must be certified by the Independent Financial Auditor (statutory Auditor) of the company appointed under the companies' Act.

- iii. In case any discrepancy in data is found between the balance sheet and the financial information submitted, the data as available in the balance sheet will be considered.
- iv. In case the audited balance sheet of the last financial year is not made available by the Bidder, he has to submit an affidavit certifying that 'The Balance Sheet has actually not been audited so far'. In such a case provisional balance sheet shall be submitted. If audited balance sheet of any year other than the last financial year is not submitted, then the bid will be considered as non-responsive
- v. In case the company's financial year is from Jan 19 to Dec 19, then it will be considered under financial year 2019 - 20 similar procedure will be applicable for other financial years also.

SEAL AND SIGNATURE OF THE BIDDER

Certified that all figures and facts submitted in this form have been furnished after full consideration of all observations/notes in Auditor's reports.

(Signature of Statutory Auditor)

Name of Statutory Auditor : _____

Registration No: _____

(Seal)

Each Bidder or each member of a JV/ Consortium must fill in this form separately:

NAME OF BIDDER/JV/CONSORTIUM PARTNER:

Sl.No.	Year	Annual Turnover	Multiplying factor	Updated Annual turnover
		INR	INR	INR
1	2017-2018			
2	2018-2019			
3	2019-2020			
4	2020-2021			
5	2021-2022			

Annual Turnover Data for the Last 5 Years (S&T Construction only)			
Year	Amount Currency	Exchange Rate	Indian National Rupees Equivalent
Average Annual Construction Turnover for last 5 Financial Years			

1. The information supplied shall be substantiated by data in the audited balance sheets and profit and loss accounts for the relevant years and submitted as attachments to form Fin-1 in respect of the bidder or all partners constituting the bidder.
2. Contents of this form should be certified by a Statutory Auditor.
3. In case the audited balance sheet of the last financial year is not made available by the Bidder, he has to submit an affidavit certifying that 'The Balance Sheet has actually not been audited so far'. In such a case provisional balance sheet shall be submitted. If audited balance sheet of any year other than the last financial year is not submitted, then the bid will be considered as non-responsive

SEAL AND SIGNATURE

Form FIN-3: Current Contract Commitments / Works in Progress

Bidders and each partner to a JV/Consortium should provide information on their current commitments on all contract that have been awarded, or which a letter of intent or acceptance has been received, or for contracts approaching completion, but for which an unqualified, full completion certificate has yet to be issued.

Contract Commitments

Sl.No	Description of work	Contract No. & date	Name & address of Employer, Tel./Fax/ Email	Value of Contract in INR	Stipulated Period of completion	Value of Balance work	Anticipated date of Completion
1							
2							
3							
4							
5							
Total							

- For calculation of 'Updated contract value" in column 5 above, assume inflation as per multiplying Factors given in FIN-2.
- Bidder should provide information on their current commitments or all contracts that have been awarded or for which a letter of intent or acceptance has been received or for contracts approaching completion but for which a completion certificate is yet to be issued.
- The exchange rate of foreign currency shall be applicable 28 days before the tender submission date. For conversion of foreign currency to Indian Rupee exchange rates published by Financial Benchmarks Private limited (www.fbil.org.in) 28 days before the date of bid submittal will be considered. In case the particular day happens to be a holiday the exchange rate published on the next working day will be considered. In case of works in foreign currency the effect of inflation is considered as included, as the exchange rate prevailing 28 days before tender submission is being considered for conversion to Indian Rupees,
Note: Enclose Certificate(s) from Engineer(s) Incharge (not below the rank of Executive Engineer) for Value of outstanding work. In case it is not feasible to furnish certificate from all the units the bidder should record the following certificate on Fin 3:

"Certified that current commitments on all the contracts that have been awarded or for which a letter of intent or acceptance has been received or for the works in progress or the works approaching completion, value of outstanding work has been indicated in the above table correctly. It is further certified that if later on the employer discovers that information provided in the table is incorrect then the employer will treat our bid invalid and it will be liable for rejection"

SEAL AND SIGNATURE

DELETED

K-RIDE

FORM NO. 2

**CHECKLIST FOR CLAUSES PERTAINING TO SUMMARY
REJECTION OF BID**

We, the undersigned, declare that we have read and understood the content of ITT clauses section:2 mentioned below. We also understand that our bid shall be summarily rejected in case we fail to comply the requirements of undermentioned clauses:

ITT Clause No. Section 2	Reason for Summary Rejection
2.5	Non-submission of Affidavit- (Form PS-3)
11.5 & 22	Non-submission of immediate information to the Employer in case Bidder ceases to fulfill eligibility in terms of ITT clause 2
11.5	Quoting more than one percentage for any schedule
11.5	Non-submission of the Letter of Technical Bid (LTB)
11.5	Non-submission of the Letter of Price Bid (LPB)
13	Bid not accompanied with bid security
14	Bid not accompanied with power of attorney/General power of Attorney to sign on behalf of the bidders

SEAL AND SIGNATURE OF THE BIDDER

Form: 3 C 1

FORMAT FOR CERTIFICATE TO BE SUBMITTED BY BIDDER ALONGWITH THE BID
(On the letter head of the Firm)

We/I, _____, having registered office at _____ do hereby certify that "I have read the clause regarding restrictions on procurement from a bidder of a country which shares a land border with India; I certify that this bidder is not from such country or, if from such a country, has been registered with the Competent Authority. I hereby certify that this bidder fulfils all requirements in this regard and is eligible to be considered. (Where applicable, evidence of valid registration by the competent Authority shall be attached.)"

Dated this _____ day of _____, 2022

For- _____

Authorized Signatory Signature _____

Full Name: _____

Place: _____

(SEAL AND SIGNATURE OF THE BIDDER)

Form: 3 C 2

**FORMAT FOR CERTIFICATE TO BE SUBMITTED BY
BIDDER ALONGWITH THE BID FOR SUB CONTRACTING**

(On the letter head of the Firm)

We/I, _____, having registered office at _____ do hereby certify that "I have read the clause regarding restrictions on procurement from a bidder of a country which shares a land border with India and on sub-contracting to contractors from such countries; I certify that this bidder is not from such a country or, if from such a country, has been registered with the competent Authority and will not sub-contractor any work to a contractor from such countries unless such contractor is registered with the competent Authority. I hereby certify that his bidder fulfils all requirements in this regard and is eligible to be considered. (Where applicable, evidence of valid registration the Competent Authority shall be attached.)"

Dated this _____ day of _____, 2022

For- _____

Authorized Signatory Signature _____

Full Name: _____

Place: _____

(SEAL AND SIGNATURE OF THE BIDDER)

Form 5

Key Personnel for the work

MINIMUM QUALIFICATION AND EXPERIENCE REQUIRED FOR KEY PERSONNEL TO BE DEPLOYED FOR THE WORK

SI . N o.	Key Personnel	Qualifications & Total Experience	Particular Experience (Minimum requirement)	Minimum Number of Personnel Required	Name of the key personnel proposed	Qualification	Total number of years of experience	Number of Years in similar works experience
1	Sr. Engineers	Engineering Graduate in Electronics/Elect.	3years Experience in construction of EI/RR/PI	2				
2	Supervisors/S&T	Diploma in Electronics/Elect.	Min 3 years Experience in construction of EI/RR/PI	2				
3	Draftsman with knowledge of AUTOCAD S&T	Minimum Diploma in Electrical/Electronics/Communication Engineering OR a combination of basic streams of Electrical/Electronics/Communication Engg with 3 years	Min 3 years with AutoCAD working , SIP and other S&T document preparation	1				

4	Wire man	5 years experience as wireman	5 years experience in S&T wiring, circuit tracing and other S&T works.	6				
---	----------	-------------------------------	--	---	--	--	--	--

Note: 1) Further details to be updated as per clause 3.3 (c) of section 2 ITT.

2) The CV's to be given for Serial No. 1 to 3 as per Form-6 of section- (Qualification information /Bidding Forms).

(Signature)

(Name of Signatory)

(Capacity of Signatory)

Seal.....

K-RIDE

Format of Curriculum Vitae (cv) for proposed key professional staff

Proposed Position:

Name of Firm:

Name of Staff:

Profession:

Date of Birth:

Years with Firm/Entity: Nationality:

Membership in Professional Societies:

Detailed Tasks Assigned:

Key Qualifications:

[Give an outline of staff member’s experience and training most pertinent to tasks on assignment. Describe degree of responsibility held by staff member on relevant previous assignments and give dates and locations.]

Education:

[Summarize college/university and other specialized education of staff member and degrees obtained.]

Employment Record:

[Starting with present position, list in reverse order every employment held. List all positions held by staff member since graduation, giving dates, names of employing organizations, titles of positions held, and locations of assignments. Also give types of activities performed and client references, where appropriate.]

Period	Name of Employing Organization	Name of the Project	Title / Position	Activity performed	Location of the Assignment

Languages:

[For each language, indicate proficiency: excellent, good, fair, or poor; in speaking, reading, and writing]

Certification:

I, the undersigned, certify that to the best of my knowledge and belief, these data correctly describe me, my qualifications, and my experience.

Date:

[Signature of staff member and authorized representative of the Firm] Day/Month/Year

Full name of staff member: _____

Full name of the authorized representative: _____

FORM CL-2

UNDERTAKING FROM NOMINATED/IDENTIFIED SUB-CONTRACTOR

(Refer Clause of EQC)

(On the Letterhead of Nominated/Identified sub-contractor)

I/We,.....(Legal Name of Specialist Subcontractor) hereby confirm that we are associating with(Legal name of the bidder) for the work of(Name of work as stated in Invitation for Bids {IFB}), for the key activity stated in clause 3.2 (c) of ITT (if applicable).

I/We hereby undertake that in case M/s.....(Legal name of the bidder) are awarded the work of(Name of work as stated in Invitation for Bids {IFB}),the key activity stated in clause 3.2 (c) of ITT shall be undertaken by us as per bid conditions (if applicable).

**STAMP & SIGNATURE OF AUTHORISED
SIGNATORY OF NOMINATED/IDENTIFIED SUB CONTRACTOR**

**STAMP & SIGNATURE OF AUTHORISED
SIGNATORY OF BIDDER**

Form CL-3

Availability of Financial Resources
(Section-2, ITT clause 3.3 (b))

Bidders must demonstrate sufficient financial resources, comprising of Working Capital supplemented by credit line statements or overdraft facilities to meet the Bidder's financial requirements for

- a) its current contract commitments, and
- b) the subject contract.

In case of a Joint Venture, each Joint Venture Partner must fill out this form separately and provide the Joint Venture Partner's name:

Joint Venture Partner: _____

Financial Resources		
No.	Source of financing	Amount (equivalent)
1	Working Capital	
2	Credit Line	
Total Available Financial Resources		

^aTo be considered, Credit Line must be substantiated by a letter from the bank issuing the line of credit, specific for the subject contract, as prescribed. Any letter or document not complying with this requirement shall not be considered as supplementary financial resources.

Note:

In case the financial statement data is other than Indian Rupees, the equivalent Indian Rupees with the exchange rates as defined in the Section-2, ITT.

Evidence of Availability of Credit Line Financial Resources
(Section-2 ITT, Clause:3(b))

[Each Bidder must fill out this form to demonstrate financial resources comprising credit line statements or overdraft facilities.]

Project Name:

Bidding Package Name and Identification Number: (to be filled in as indicated in ITT 1) ...

BANK CERTIFICATE

This is to certify that M/s is a reputed company with a good financial standing.

If the contract for the work, namely..... is awarded to the above firm, we shall be able to provide overdraft / credit facilities to the extent of Rs to meet their working capital requirements for executing the above contract.

___ Sd. ___

Name of Bank: _____

Senior Bank Manager _____

Address of the Bank _____

[In case of Joint Venture, change the text as follows:]

This is to certify that M/s who has formed a Joint Venture with M/s and M/s for participating in this bid, is a reputed company with a good financial standing.

If the contract for the work, namely..... is awarded to the above joint venture, we shall be able to provide overdraft / credit facilities to the extent of Rs..... to M/s to meet their working capital requirements for executing the above contract.

Form EXP-1**WORK EXPERIENCE CERTIFICATE**

To whom so ever it may concern
(Issued for the purpose of Quoting in K-RIDE tenders)

M/s/Sri (Name and address of the contractor) is a working contractor of this unit ad was awarded the following work. The relevant details of the work are as under: -

Sl.No	Description	Details
1	Name of work	
2	Acceptance Letter No and Date	
3	Agreement Number, date and name of the agency	
4	Agreement value in Rupees (in words and figures)	
5	Due date of completion	
6	Actual date of completion of work	
7	Value of Final Bill if passed (in words)	
8	Work completed but Final measurements not recorded. a) Amount paid so far as in CC bill No.	
9	Work completed. Final measurements recorded with negative variation a) Amount so far paid as in CC bill No.	
10	Work completed. If Final measurements recorded with Positive variation which is not sanctioned yet. Original agreement value of Last sanctioned agreement value whichever is lower.	
11	Scope of work (Broad category of works i.e., the name of the work in the agreement on which work is	
12	Details of values of major components/ works executed in the completed work.	

Note:

The Certificate to satisfy similar work should be signed by an officer not lower than JAG officer in Railways and Executive Engineer rank or equivalent grade in other department of Govt. of India/State Government/PSUs of Government of India / State Undertaking and Competent Authority of Public Listed Company.

Signature :.....

Name of officer.....

Designation:

Address:

Office seal:

Phone/FAX No.:

Date :

--00--00--00--

SECTION-4

**FORM OF TENDER, LETTER OF ACCEPTANCE,
NOTICE TO PROCEED WITH THE WORK AND
AGREEMENT FORM ETC.,**

FORM OF TENDER, LETTER OF ACCEPTANCE, NOTICE TO PROCEED WITH THE WORK AND AGREEMENT FORM ETC.,

SL. NO.	TITLE	FORM NUMBER	PAGE NO.
1	LETTER OF ACCEPTANCE	FORM-1	89
2	ISSUE OF NOTICE TO PROCEED WITH THE WORK	FORM-2	90
3	AGREEMENT FORM	FORM-3	91

K-RIDE

FORM OF TENDER (DELETED)

Please refer Form PS-1 of Section 3: Qualification Information/Bidding Forms.

K-RIDE

LETTER OF ACCEPTANCE(Letter head paper of the Employer)

_____ [date]

To: _____ [name and address of the Contractor]

Dear Sirs,

This is to notify you that your Tender dated _____ for execution of the **“Signaling Outdoor and indoor works with Distributed Electronic interlocking (EI) at Yesvantpur Jn. in connection with doubling of Yesvantpur-Channasandra section of Bangalore Division”**

Tender No: K-RIDE/DL/SnT/13/2022, Dated: -----for the Contract Price of Rupees_____.(_____[amount in words and figures], as corrected and modified in accordance with the Instructions to Tenderers is hereby accepted by our Agency.

You are hereby requested to furnish Performance Security plus additional security for unbalanced tenders in accordance with of Clause 25.5 of ITT, in the form detailed in Clause 29.1 of ITT and clause 43 of the conditions of contract for an amount of Rs._____(As defined in contract data) within 20 days of the receipt of this letter of acceptance

Yours faithfully,

Authorized Signature

Name and Title of Signatory

Name of Agency.

ISSUE OF NOTICE TO PROCEED WITH THE WORK

(Letter head of the Employer)

_____ (Date)

To

_____ (name and address of the Contractor)

Dear Sirs:

With reference to LOA, for the construction of **“Signaling Outdoor and indoor works with Distributed Electronic interlocking (EI) at Yesvantpur Jn. in connection with doubling of Yesvantpur-Channasandra section of Bangalore Division”**

a Tender Price of Rs. _____, you are hereby instructed to proceed with the execution of the said works in accordance with the contract documents.

Yours faithfully,

(Signature, name and title of signatory authorized to sign
on behalf of Employer)

AGREEMENT FORM**Agreement**

This agreement, made the _____ day of _____ 20_____,
between _____

_____ (Name and Address of Employer) (herein after called "the
Employer") of the _____ one part and
_____ [nam
e and address of contractor] (herein after called "the Contractor") of the other part.

Whereas the Employer is desirous that the Contractor execute, "**Signaling Outdoor and indoor works with Distributed Electronic interlocking (EI) at Yesvantpur Jn. in connection with doubling of Yesvantpur-Channasandra section of Bangalore Division**", Tender No.K-RIDE/DL/SnT/13/2022, Dated: _____ (herein after called "The Works") and the Employer has accepted the Tender by the Contractor for the execution and completion of such Works and the remedying of any defects therein at a contract price of Rupees.....

NOW THIS AGREEMENT WITNESSETH as follows:

1. In this Agreement, words and expression shall have the same meanings as are respectively assigned to them in the Conditions of Contract hereinafter referred to, and they shall be deemed to form and be read and construed as part of this Agreement.
2. In consideration of the payments to be made by the Employer to the Contractor as hereinafter mentioned, the Contractor hereby covenants with the Employer to execute and complete the Works and remedy any defects therein in conformity in all aspects with the provisions of the Contract.
3. The Employer hereby covenants to pay the Contractor in consideration of the execution and completion of the Works and the remedying the defects wherein the Contract Price or such other sum as may become payable under the provisions of the Contract at the times and in the manner prescribed by the Contract.
4. The following documents shall be deemed to form and be read and construed as part of this Agreement, viz:
 - i) Letter of Acceptance;
 - ii) Notice to proceed with the works;
 - iii) Contractor's Tender;
 - iv) Contract Data;
 - v) Conditions of contract (including Special Conditions of Contract and Particular Condition of Contract)
 - vi) Specifications;
 - vii) Drawings;
 - viii) Bill of Quantities; and
 - ix) Any other document listed in the Contract Data as forming part of the contract.

In witness whereof the parties thereto have caused this Agreement to be executed the day and year first before written.

The Common Seal of _____

was hereunto affixed in the presence of:

Signed, Sealed and Delivered by the said _____

in the presence of:

Binding Signature of Employer _____

Binding Signature of Contractor _____

SECTION – 5

CONDITIONS OF CONTRACT(CC) AND SPECIAL CONDITIONS OF CONTRACT (SCC)

CONDITIONS OF CONTRACT**TABLE OF CONTENTS**

SI NO.	DESCRIPTION	PAGE NO
	A. GENERAL	
1	DEFINITIONS	95-96
2	INTERPRETATION	96
3	LAW GOVERNING CONTRACT	96
4	EMPLOYERS DECISIONS	96
5	DELEGATION	96
6	COMMUNICATIONS	97
7	SUB-CONTRACTING	97
8	OTHER CONTRACTORS	97
9	PERSONNEL	97
10	EMPLOYER'S & CONTRACTOR'S RISKS	97
11	EMPLOYER'S RISKS	97
12	CONTRACTOR'S RISKS	98
13	INSURANCE	98
14	SITE INVESTIGATION REPORTS	98
15	QUERIES ABOUT THE CONTRACT DATA	98
16	CONTRACTOR TO CONSTRUCT THE WORKS	98
17	THE WORKS TO BE COMPLETED BY THE INTENDED COMPLETION	99
18	APPROVALS BY THE EMPLOYER	99
19	SAFETY	99
20	DISCOVERIES	99
21	POSSESSION OF THE SITE	99
22	ACCESS TO SITE	99
23	INSTRUCTIONS	99
24	PROCEDURE FOR RESOLUTION OF DISPUTES	100
	B. TIME CONTROL	
25	PROGRAM	100
26	EXTENSION OF THE INTENDED COMPLETION DATE	100
27	DELAYS ORDERED BY THE EMPLOYER	100
28	MANAGEMENT MEETINGS	100
	C. QUALITY CONTROL	
29	IDENTIFYING DEFECTS	101
30	TESTS	101
31	CORRECTION OF DEFECTS	101
32	UNCORRECTED DEFECTS	101
	D. COST CONTROL	
33	BILL OF QUANTITIES	101
34	VARIATIONS	101-102
35	PAYMENTS FOR VARIATIONS	102
36	SUBMISSION OF BILLS FOR PAYMENT	103
37	PAYMENTS	103
38	COMPENSATION EVENTS	103-104
39	TAX	104

SECTION – 5: CONDITIONS OF CONTRACT(CC) AND SPECIAL CONDITIONS OF CONTRACT (SCC)

40	PRICE ADJUSTMENT	104
41	LIQUIDATED DAMAGES	104-105
42	ADVANCE PAYMENTS	105
43	SECURITIES	105
44	COST OF REPAIRS	105
	E. FINISHING THE CONTRACT	
45	COMPLETION	105
46	TAKING OVER	105
47	FINAL ACCOUNT	106
48	AS BUILT DRAWINGS / OPERATING AND MAINTENANCE MANUALS	106
49	TERMINATION	106-107
50	PAYMENT UPON TERMINATION	107
51	PROPERTY	107
52	RELEASE FROM PERFORMANCE	107
	F. SPECIAL CONDITIONS OF CONTRACT	
53	LABOUR	108
54	COMPLIANCE WITH LABOUR REGULATIONS	108
55	PROTECTION OF ENVIRONMENT	108
56	CLAIMS, DISPUTES AND ARBITRATION	108-112
57	Jurisdiction of Courts	112

CONDITIONS OF CONTRACT

A. GENERAL

1. DEFINITIONS

- 1.1 Terms which are defined in the Contract Data are not also defined in the Conditions of Contract but keep their defined meanings. Bold letters are used to identify defined terms.

Bill of Quantities means the priced and completed Bill of Quantities forming part of the Tender.

Compensation Events are those defined in Clause 38 hereunder.

The **Completion Date** is the date of completion of the Works as certified by the Employer in accordance with Sub Clause 46.1.

The **Contract** is the contract between the Employer and the Contractor to execute, complete and maintain the Works. It consists of the documents listed in Clause 2.2 below.

The **Contract Data** defines the documents and other information which comprise the Contract.

The **Contractor** is a person or corporate body or Joint Venture whose Tender to carry out the Works has been accepted by the Employer.

The **Contractor's Tender** is the completed Tender document submitted by the Contractor to the Employer.

The **Contract Price** is the price stated in the Letter of Acceptance and thereafter as adjusted in accordance with the provisions of the Contract.

Days are calendar days; **months** are calendar months.

A **Defect** is any part of the Works not completed in accordance with the Contract.

The **Defects liability period** is the period named in the Contract Data and calculated from the Completion Date.

The **Employer** is the party who will employ the Contractor to carry out the Works.

Equipment is the Contractor's machinery and vehicles brought temporarily to the Site to construct the Works.

The **Initial Contract price** is the Contract Price listed in the Employer's Letter of Acceptance.

The **Intended Completion Date** is the date on which it is intended that the Contractor shall complete the Works. The Intended Completion Date is specified in the Contract Data. The Intended Completion Date may be revised only by the Employer by issuing an extension of time.

'Joint Venture' means an ad hoc association of firms that pool their resources and skills to undertake a large or complex contract in the role of "Contractor," with all firms (partners in the JV) being legally liable, jointly and severally, for the execution of the Contract in the event of a partner's withdrawal.

Materials are all supplies, including consumables, used by the contractor for incorporation in the Works.

Plant is any integral part of the Works which is to have a mechanical, electrical, electronic or chemical or biological function.

The **Site** is the area defined as such in the Contract Data.

Specification means the Specification of the Works included in the Contract and any modification or addition made or approved by the Employer.

The **Start Date** is given in the Contract Data. It is the date when the Contractor shall commence execution of the works. It does not necessarily coincide with any of the Site Possession Dates.

A Subcontractor is a person or corporate body who has a Contract with the Contractor to carry out a part of the work in the Contract which includes work on the Site.

A **Variation** is an instruction given by the Employer which varies the Works.

The **Works** are what the Contract requires the Contractor to construct, install, and turn over to the Employer, as defined in the Contract Data.

2. INTERPRETATION

2.1 In interpreting these Conditions of Contract, singular also means plural, male also means female or neuter, and the other way around. Headings have no significance. Words have their normal meaning under the language of the Contract unless specifically defined. The Employer will provide instructions clarifying queries about the Conditions of Contract.

2.2 The documents forming the Contract shall be interpreted in the following order of priority:

- (1) Agreement
- (2) Letter of Acceptance, notice to proceed with the works
- (3) Contractor's Tender
- (4) Contract Data
- (5) Conditions of Contract
- (6) Specifications
- (7) Drawings
- (8) Bill of quantities and
- (9) any other document listed in the Contract Data as forming part of the Contract.

3. LAW GOVERNING CONTRACT

3.1 The law governing the Contract is the Laws of India supplanted by the Karnataka Local Acts.

4. EMPLOYER'S DECISIONS

4.1 Except where otherwise specifically stated, the Employer will decide contractual matters between the Employer and the Contractor.

5. DELEGATION

SECTION – 5: CONDITIONS OF CONTRACT(CC) AND SPECIAL CONDITIONS OF CONTRACT (SCC)

5.1 The Employer may delegate any of his duties and responsibilities to other people after notifying the Contractor and may cancel any delegation after notifying the Contractor.

6. COMMUNICATIONS

6.1 Communications between parties which are referred to in the conditions are effective only when in writing. A notice shall be effective only when it is delivered (in terms of Indian Contract Act).

7. SUBCONTRACTING:

7.1 The Contractor may subcontract with the approval of the Employer but may not assign the Contract without the approval of the Employer in writing. Subcontracting does not alter the Contractor's obligations.

8. OTHER CONTRACTORS

8.1 The Contractor shall cooperate and share the Site with other contractors, public authorities, utilities, and the Employer.

9. PERSONNEL

9.1 The Contractor shall employ the technical personnel (of number and qualifications) as may be stipulated by K-RIDE from time to time during the execution of the work. The technical staff so employed shall be available at site as may be stipulated by the Employer.

9.2 If the Employer asks the Contractor to remove a person who is a member of the Contractor's staff or his work force stating the reasons, the Contractor shall ensure that the person leaves the Site within seven days and has no further connection with the work in the Contract.

10. EMPLOYER'S AND CONTRACTOR'S RISKS

10.1 The Employer carries the risks which this Contract states are Employer's risks, and the Contractor carries the risks which this Contract states are Contractor's risks.

11. EMPLOYER'S RISKS

11.1 The Employer is responsible for the excepted risks which are:

- (a) Rebellion, riot commotion or disorder unless solely restricted to employees of the Contractor or his Sub Contractors arising from the conduct of the Works; or
- (b) a cause due solely to the design of the Works, other than the Contractor's design; or

- (i) could not have reasonably foreseen; or

- (ii) could reasonably have foreseen, but against which he could not reasonably have taken at least one of the following measures;

- (A) prevent loss or damage to physical property from occurring by taking appropriate measures or

- (B) insure against such loss or damage

12. CONTRACTOR'S RISKS

- 12.1 All risks of loss of or damage to physical property and of personal injury and death which arise during and in consequence of the performance of the Contract other than the excepted risks are the responsibility of the Contractor.

13. INSURANCE:

- 13.1 The Contractor shall prior to commencing the works, effect and thereafter maintain insurances, in the joint names of the Employer and the Contractor, (cover from the first working day after the Start Date to the end of Defects Liability Period), in the amounts stated in the Contract Data:

- (a) for loss of or damage to the Works, Plants and Materials and the Contractor's equipment;
- (b) for liability of both Parties for loss, damage, death and injury to third parties or their property arising out of the Contractor's performance of the Contract including the Contractor's liability for damage to the Employer's property other than the Works and
- (c) for liability of both Parties and of any Employer's representative for death and injury to the Contractor's personnel except to the extent that liability arises from the negligence of the Employer, any Employer's representative or their Employees.

- 13.2 Policies and certificates for insurance shall be delivered by the Contractor to the Employer for his approval before the Start Date. All such insurance shall provide for compensation to be payable to rectify the loss or damage incurred. All payments received from insurers relating to loss or damage shall be held jointly by the Parties and used for the repair of the loss or damage or as compensation for loss or damage that is not to be repaired.

- 13.3 If the Contractor fails to effect or keep in force any of the insurances referred to in the previous sub-clauses or fails to provide satisfactory evidence, policies or receipts, the Employer may without prejudice to any other right or remedy, effect insurance for the cover relevant to such default and pay the premiums due and recover the same as a deduction from any other monies due to the Contractor. If no payments is due, the payment of the premiums shall be a debt due.

- 13.4 Alterations to the terms of an insurance shall not be made without the approval of the Employer.

- 13.5 Both Parties shall comply with any conditions of the insurance policies.

14. SITE INVESTIGATION REPORTS:

- 14.1 The Contractor, in preparing the tender, shall rely on any site investigation reports referred to in the Contract data, supplemented by any information available to the Tenderer.

15. QUERIES ABOUT THE CONTRACT DATA

- 15.1 The Employer will clarify queries on the Contract Data.

16. CONTRACTOR TO CONSTRUCT THE WORKS

16.1 The Contractor shall construct the Works in accordance with the Specification and Drawings.

17. THE WORKS TO BE COMPLETED BY THE INTENDED COMPLETION DATE

17.1 The Contractor may commence execution of the Works on the Start Date and shall carry out the Works in accordance with the program submitted by the Contractor, as updated with the approval of the Employer, and complete them by the Intended Completion Date.

18. APPROVAL BY THE EMPLOYER:

18.1 The Contractor shall submit Specification and drawings showing the proposed Temporary Works to the Employer, who is to approve them if they comply with the Specifications and Drawings.

18.2 The Contractor shall be responsible for the design of Temporary Works and Permanent works

18.3 The Employer's approval shall not alter the Contractor's responsibility for design of the Temporary Works and Permanent works

18.4 The Contractor shall obtain approval of third parties to design of the temporary Works and Permanent where required.

18.5 All Drawings prepared by the Contractor for the execution of the temporary or permanent Works, are subject to prior approval by the Employer before their use.

19. SAFETY

19.1 The Contractor shall be responsible for the safety of all activities on the Site.

20. DISCOVERIES

20.1 Anything of historical or other interest or of significant value unexpectedly discovered on the Site is the property of the Employer. The Contractor is to notify the Employer of such discoveries and carry out the Employer's instructions for dealing with them.

21. POSSESSION OF THE SITE

21.1 The Employer shall give possession of all parts of the Site to the Contractor progressively, If possession of a part is not given by the date stated in the Contract Data the Employer is deemed to have delayed the start of the relevant activities and this will be compensation event.

22. ACCESS TO THE SITE

22.1 The Contractor shall allow the Employer and any person authorized by the Employer access to the Site, to any place where work in connection with the Contract is being carried out or is intended to be carried out and to any place where materials or plant are being manufactured / fabricated / assembled for the works.

23. INSTRUCTIONS

23.1 The Contractor shall carry out all instructions of the Employer which comply with the applicable laws where the Site is located.

24 PROCEDURE FOR RESOLUTION OF DISPUTES:

- 24.1 If the Contractor is not satisfied with the decision taken by the Employer, the dispute shall be referred by either party to Arbitration within 30 days of the notification of the Employer's decision.
- 24.2 If neither party refers the dispute to Arbitration within the above 30 days, the Employer's decision will be final and binding.
- 24.3 The Arbitration shall be conducted in accordance with the arbitration procedure stated in the Special Conditions of Contract.

B. TIME CONTROL

25. PROGRAM

- 25.1 Within the time stated in the Contract Data the Contractor shall submit to the Employer for approval a Program showing the general methods, arrangements, order, and timing for all the activities in the Works.
- 25.2 The Employer's approval of the Program shall not alter the Contractor's obligations. The Contractor may revise the Program and submit it to the Employer again at any time. A revised Program is to show the effect of Variations and Compensation Events.

26. EXTENSION OF THE INTENDED COMPLETION DATE

- 26.1 The Employer shall extend the Intended Completion Date if a Compensation Event occurs or a Variation is issued which makes it impossible for Completion to be achieved by the Intended Completion Date.
- 26.2 The Employer shall decide whether and by how much to extend the Intended Completion Date within 21 days of the Contractor asking the Employer for a decision upon the effect of a Compensation Event or Variation and submitting full supporting information.

27. DELAYS ORDERED BY THE EMPLOYER

- 27.1 The Employer may instruct the Contractor to delay the start or progress of any activity within the Works.

28. MANAGEMENT MEETINGS

- 28.1 The Employer may require the Contractor to attend a management meeting. The business of a management meeting shall be to review the progress achieved and the plans for remaining work.
- 28.2 The responsibility of the parties for actions to be taken is to be decided by the Employer either at the management meeting or after the management meeting and stated in writing to be distributed to all who attended the meeting.

C. QUALITY CONTROL

29. IDENTIFYING DEFECTS

- 29.1 The Employer shall check the Contractor's work and notify the Contractor of any Defects that are found. Such checking shall not affect the Contractor's responsibilities. The Employer may instruct the Contractor to search for a Defect and to uncover and test any work that the Employer considers may have a Defect.

30. TESTS

- 30.1 If the Employer instructs the Contractor to carry out a test not specified in the Specification to check whether any work has a Defect and the test shows that it does, the Contractor shall pay for the test and any samples. If there is no Defect the test shall be a Compensation Event.

31. CORRECTION OF DEFECTS

- 31.1 The Employer shall give notice to the Contractor of any Defects before the end of the Defects Liability Period, which begins at Completion and is defined in the Contract Data. The Defects Liability Period shall be extended for as long as Defects remain to be corrected.
- 31.2 Every time notice of a Defect is given, the Contractor shall correct the notified Defect within the length of time specified by the Employer's notice.

32. UNCORRECTED DEFECTS

- 32.1 If the Contractor has not corrected a Defect within the time specified in the Employer's notice, the Employer will assess the cost of having the Defect corrected, and the Contractor will pay this amount.

D. COST CONTROL

33. BOQ

- 33.1 The BOQ shall contain items for the construction, installation, testing, and commissioning work to be done by the Contractor.
- 33.2 The BOQ is used to calculate the Contract Price. The Contractor is paid for the quantity of the work done at the rate in the BOQ for each item.

34. VARIATIONS

- 34.1 The Employer shall have power to order the Contractor to do any or all of the following as considered necessary or advisable during the progress of the work by him

SECTION – 5: CONDITIONS OF CONTRACT(CC) AND SPECIAL CONDITIONS OF CONTRACT (SCC)

- (a) Increase or decrease of any item of work included in the BOQ;
 - (b) Omit any item of work;
 - (c) Change the character or quality or kind of any item of work;
 - (d) Change the levels, lines, positions and dimensions of any part of the work;
 - (e) Execute additional items of work of any kind necessary for the completion of the works; and
 - (f) Change in any specified sequence, methods or timing of construction of any part of the work.
- 34.2 The Contractor shall be bound to carry out the work in accordance with any instructions in this connection, which may be given to him in writing by the Employer and such alteration shall not vitiate or invalidate the contract.
- 34.3 Variations shall not be made by the Contractor without an order in writing by the Employer, provided that no order in writing shall be required for increase or decrease in the quantity of an item appearing in the BOQ so long as the work executed conforms to the approved drawings.
- 34.4 The Contractor shall promptly request in writing to the Employer to confirm verbal orders and the officer issuing oral instructions shall confirm it in writing within 30 days of request, failing which the work shall be carried out as though there is no variation. In case variation is approved it shall be accompanied with BOQ, failing which the contractor shall be responsible for deviation if any.
- 35. PAYMENTS FOR VARIATIONS**
- 35.1 Payment for increase in the quantities of an item in the BOQ up to 25% of that provided in the Bill of Quantities shall be made at the rates quoted by the Contractor.
- 35.2 For quantities in excess of 125% of the tendered quantity of an item as given in the BOQ, the Contractor shall be paid at the rate entered in or derived from in the Schedule of Rates (applicable for the area of the work and current at the time of award of contract) plus or minus the overall percentage of the original tendered rates over the current Schedule of Rates prevalent at the time of award of contract.
- 35.3 If there is no rate for the additional, substituted or altered item of the work in the BOQ, efforts would be made to derive the rates from those given in the BOQ or the Schedule of Rates (applicable for the area of the work and current at the time of award of contract) and if found feasible the payment would be made at the derived rate for the item plus or minus the overall percentage of the original tendered rates over the current Schedule of Rates prevalent at the time of award of contract.
- 35.4 If the rates for additional, substituted or altered item of work cannot be determined either as at 35.1 or 35.2 or 35.3 above, the Contractor shall be requested to submit his quotation for the items supported by analysis of the rate or rates claimed, within 7 days.
- 35.5 If the Contractor's quotation is determined unreasonable, the Employer may order the Variation and make a change to the Contract Price which shall be based on Employer's own forecast of the effects of the Variation on the Contractor's costs.
- 35.6 If the Employer decides that the urgency of varying the work would prevent a quotation being given and considered without delaying the work, no quotation shall be given and the Variation

shall be treated as a Compensation Event.

- 35.7 Under no circumstances the Contractor shall suspend the work on the plea of non-settlement of rates for items falling under this Clause.

36. SUBMISSION OF BILLS FOR PAYMENT

- 36.1 The Contractor shall submit to the Employer monthly bills of the value of the work completed less the cumulative amount paid previously.

- 36.2 The Employer shall check the Contractor's bill and determine the value of the work executed which shall comprise of (i) value of the quantities of the items in the BOQ completed and (ii) valuation of Variations and Compensation Events.

- 36.3 The Employer may exclude any item paid in a previous bill or reduce the proportion of any item previously paid in the light of later information.

37. PAYMENTS

- 37.1 Payments shall be adjusted for deductions for advance payments other than recoveries in terms of contract and taxes, at source as applicable under law. The Employer shall pay the Contractor within 60 days of submission of bill. The Contractor shall be liable to pay liquidated damages for shortfall in progress.

- 37.2 Items of the Works for which no rate or price has been entered in will not be paid for by the Employer and shall be deemed covered by other rates and prices in the Contract.

38. COMPENSATION EVENTS:

- 38.1 The following are Compensation Events unless they are caused by the Contractor:

- (a) The Employer orders a delay or does not issue drawings, specifications or instructions required for execution of works on time.
- (b) The Employer instructs the Contractor to uncover or to carry out additional tests upon work which is then found to have no Defects.
- (c) The Employer gives an instruction for dealing with an unforeseen condition, caused by the Employer, or additional work required for safety or other reasons.
- (d) The effect on the Contractor of any of the Employer's Risks.
- (e) The Employer unreasonably delays issuing a Certificate of Completion.

Other Compensation Events listed in the Contract Data or mentioned in the Contract

- 38.2 If a Compensation Event would cause additional cost or would prevent the work being completed before the Intended Completion Date, the Contract Price shall be increased and/or the Intended Completion Date is extended. The Employer shall decide whether and by how much the Contract Price shall be increased and whether and by how much the Intended Completion Date shall be extended.

38.3 As soon as information demonstrating the effect of each Compensation event upon the Contractor's forecast cost has been provided by the Contractor, it is to be assessed by the Employer and the Contract Price shall be adjusted accordingly. If the Contractor's forecast is deemed unreasonable, the Employer shall adjust the Contract Price based on Employer's own forecast. The Employer will assume that the Contractor will react competently and promptly to the event.

38.4 The Contractor shall not be entitled to compensation to the extent that the Employer's interests are adversely affected by the Contractor not having given early warning or not having cooperated with the Employer.

39. TAX

39.1 The rates quoted by the Contractor shall be deemed to be inclusive of the sales, GST and other taxes that the Contractor will have to pay for the performance of this Contract. The Employer will perform such duties in regard to the deduction of such taxes at source as per applicable law.

40. PRICE ADJUSTMENT:

**CHANGE IN COSTS - PRICE ADJUSTMENT
PRICE ADJUSTMENT CLAUSE FOR WORKS CONTRACTS**

Contract price shall be adjusted for increase or decrease in rates and prices of labour, materials, fuels and lubricants in accordance with the following principles and procedures and as per formula given here under.

(a) The price Adjustment shall apply for the work done from the date of commencement up to the end of original period of completion and shall not apply to work carried out beyond the stipulated period of completion for reasons attributable to the Contractor.

(b) The Price adjustment shall be determined during each quarter from the formula given in contract data.

(c) Following expression and meanings are assigned to the work done during the quarter:

R - Total value of work done during the quarter. It would include the amount of secured advance for materials paid for (if any) during the quarter, less the amount of the secured advance recovered during the quarter. It will exclude value for works executed under variations for which price adjustment (if any) will be worked out separately based on the terms mutually agreed.

(d) To the extent that full compensation for any rise or fall in costs to the contractor is not covered by the provisions of this or other Clauses in the Contract, the unit rates included in the contract shall be deemed to include amounts to cover the contingency of such other rise or fall in costs.

41. LIQUIDATED DAMAGES

41.1 The Contractor shall pay liquidated damages to the Employer at the rate per day stated in the Contract Data for each day that the Completion Date is later than the Intended Completion Date (for the whole of the works or the milestone as stated in the Contract Data). The total amount of liquidated damages shall not exceed the amount defined in the Contract Data. The Employer

may deduct liquidated damages from payments due to the Contractor. Payment of liquidated damages does not affect the Contractor's liabilities.

- 41.2 If the Intended Completion Date is extended after liquidated damages have been paid, the Employer shall correct any overpayment of liquidated damages by the Contractor by adjusting the next payment of bill.

42. ADVANCE PAYMENTS:

- 42.1 The Employer shall make payment to the Contractor of the amounts stated in the Contract Data by the date stated in the Contract Data, against provision by the Contractor of an unconditional bank guarantee in a form acceptable to the Employer issued by a Nationalized/Scheduled Bank in amounts equal to the advance payment. The guarantee shall remain effective until the advance payment has been repaid, but the amount of the guarantee shall be progressively reduced by the amounts repaid by the Contractor. The advance payments shall be repaid with prevailing bank interest.

- 42.2 The Contractor is to use the advance payment only to pay for Mobilization expenses required specifically for execution of the Works. The Contractor shall demonstrate that advance payment has been used in this way by supplying copies of invoices or other documents to the Employer

- 42.3 The advance payment shall be repaid by deducting proportionate amounts from payments otherwise due to the Contractor, following the schedule of completed percentages of the Works on a payment basis. No account shall be taken of the advance payment or its repayment in assessing valuation of the work done, variations, price adjustments, compensation events or liquidated damages

43. SECURITIES:

The Performance Security (including additional security for unbalanced tenders) shall be provided to the Employer no later than the date specified in the Letter of Acceptance and shall be issued in an amount and form and type of instrument acceptable to the Employer. The Performance Security as indicated in the contract data shall be valid until a date 30 days from the date of expiry of Defects Liability Period and the additional security for unbalanced tenders shall be valid until a date 30 days from the date of issue of the certificate of completion. The security deposit will be released against BG

44. COST OF REPAIRS:

- 44.1 Loss or damage to the Works or Materials to be incorporated in the Works between the Start Date and the end of the Defects Correction periods shall be remedied by the Contractor at the Contractor's cost if the loss or damage arises from the Contractor's acts or omissions.

E. FINISHING THE CONTRACT

45. COMPLETION

- 45.1 The Contractor shall request the Employer to issue a Certificate of Completion of the Works and the Employer will do so upon deciding that the Work is completed.

46. TAKING OVER

46.1 The Employer shall take over the Site and the Works within seven days of issuing a certificate of Completion.

47. FINAL ACCOUNT

47.1 The Contractor shall supply to the Employer a detailed account of the total amount that the Contractor considers payable under the Contract before the end of the Defects Liability Period. The Employer shall issue a Defect Liability Certificate and certify any final payment that is due to the Contractor within 90 days of receiving the Contractor's account if it is correct and complete. If it is not, the Employer shall issue within 90 days a schedule that states the scope of the corrections or additions that are necessary. If the Final Account is still unsatisfactory after it has been resubmitted, the Employer shall decide on the amount payable to the Contractor and make payment within 60 days of receiving the Contractor's revised account.

48. AS BUILT DRAWINGS AND /OR OPERATING AND MAINTENANCE MANUALS

48.1 If "As Built Drawings" (Completion Drawing) and/or operating and maintenance manuals are required, the Contractor shall supply them by the dates stated in the Contract Data.

48.2 If the Contractor does not supply the Drawings by the dates stated in the Contract Data, or they do not receive the Employer's approval, the Employer shall withhold the amount stated in the Contract Data from payments due to the Contractor.

49. TERMINATION

49.1 The Employer may terminate the Contract if the other party causes a fundamental breach of the Contract.

49.2 Fundamental breaches of Contract include, but shall not be limited to the following:

- (a) the Contractor stops work for 45 days when no stoppage of work is shown on the current Program and the stoppage has not been authorized by the Employer;
- (b) - "DELETED"-
- (c) The Contractor becomes bankrupt or goes into liquidation other than for a reconstruction or amalgamation;
- (d) - "DELETED"-
- (e) the Employer gives Notice that failure to correct a particular Defect is a fundamental breach of Contract and the Contractor fails to correct it within a reasonable period of time determined by the Employer;
- (f) the Contractor does not maintain a security which is required;
- (g) the Contractor has delayed the completion of works by the number of days for which the maximum amount of liquidated damages can be paid as defined in the Contract data; and

SECTION – 5: CONDITIONS OF CONTRACT(CC) AND SPECIAL CONDITIONS OF CONTRACT (SCC)

- (h) if the Contractor, in the judgment of the Employer has engaged in corrupt or fraudulent practices in competing for or in the executing the Contract.

For the purpose of this paragraph: “corrupt practice” means the offering, giving, receiving or soliciting of anything of value to influence the action of a public official in the procurement process or in contract execution. “Fraudulent practice” means a misrepresentation of facts in order to influence a procurement process or the execution of a contract to the detriment of the Borrower, and includes collusive practice among Tenderers (prior to or after Tender submission) designed to establish Tender prices at artificial non-competitive levels and to deprive the Borrower of the benefits of free and open competition.”

- 49.3 When either party to the Contract gives notice of a breach of contract to the Employer for a cause other than those listed under Sub Clause 49.2 above, the Employer shall decide whether the breach is fundamental or not.
- 49.4 Notwithstanding the above, the Employer may terminate the Contract for convenience.
- 49.5 If the Contract is terminated the Contractor shall stop work immediately, make the Site safe and secure and leave the Site as soon as reasonably possible.

50. PAYMENT UPON TERMINATION

- 50.1 If the Contract is terminated because of a fundamental breach of Contract by the Contractor, the Employer shall prepare bill for the value of the work done less advance payments received up to the date of the bill, less other recoveries due in terms of the contract, less taxes due to be deducted at source as per applicable law and less the percentage to apply to the work not completed as indicated in the Contract Data. Additional Liquidated Damages shall not apply. If the total amount due to the Employer exceeds any payment due to the Contractor, the difference shall be a debt payable to the Employer.
- 50.2 If the Contract is terminated at the Employer's convenience, the Employer shall prepare bill for the value of the work done, the reasonable cost of removal of Equipment, repatriation of the Contractor's personnel employed solely on the Works, and the Contractor's costs of protecting and securing the Works and less advance payments received up to the date of the certificate, less other recoveries due in terms of the contract, and less taxes due to be deducted at source as per applicable law and make payment accordingly.

51. PROPERTY

- 51.1 All materials on the Site, Plant, Equipment, Temporary Works and Works are deemed to be the property of the Employer, if the Contract is terminated because of a contractor's default.

52. RELEASE FROM PERFORMANCE

- 52.1 If the Contract is frustrated by any event entirely outside the control of either the Employer or the Contractor the Employer shall certify that the Contract has been frustrated. The Contractor shall make the Site safe and stop work as quickly as possible after receiving this certificate and shall be paid for all work carried out before receiving it and for any work carried out afterwards to which commitment was made.

F. SPECIAL CONDITIONS OF CONTRACT

1. LABOUR :

The Contractor shall, unless otherwise provided in the Contract, make his own arrangements for the engagement of all staff and labour, local or other, and for their payment, housing, feeding and transport.

The Contractor shall, if required by the Employer, deliver to the Employer a return in detail, in such form and at such intervals as the Employer may prescribe, showing the staff and the numbers of the several classes of labour from time to time employed by the Contractor on the Site and such other information as the Employer may require.

2. COMPLIANCE WITH LABOUR REGULATIONS:

During continuance of the Contract, the Contractor and his sub-contractors shall abide at all times by all existing labour enactments and rules made there under, regulations, notifications and bye laws of the State or Central Government or local authority and any other labour law (including rules), regulations, bye laws that may be passed or notification that may be issued under any labour law in future either by the State or the Central Government or the local authority. The Contractor shall keep the Employer indemnified in case any action is taken against the Employer by the competent authority on account of contravention of any of the provisions of any Act or rules made there under, regulations or notifications including amendments. If the Employer is caused to pay or reimburse, such amounts as may be necessary to cause or observe, or for non-observance of the provisions stipulated in the notifications/bye laws/Acts/Rules/regulations including amendments, if any, on the part of the Contractor, Employer shall have the right to deduct any money due to the Contractor including his amount of security deposit. The Employer shall also have right to recover from the Contractor any sum required or estimated to be required for making good the loss or damage suffered by the Employer.

The employees of the Contractor and the Sub-Contractor in no case shall be treated as the employees of the Employer at any point of time.

3. PROTECTION OF ENVIRONMENT:

The Contractor shall take all reasonable steps to protect the environment on and off the Site and to avoid damage or nuisance to persons or to property of the public or others resulting from pollution, noise or other causes arising as a consequence of his methods of operation. During continuance of the contract, the Contractor and his sub-contractors shall abide at all times by all existing enactments on environmental protection and rules made there under, regulations, notifications and bye-laws of the State or Central Government, or local authorities and any other law, bye-law, regulations that may be passed or notification that may be issued in this respect in future by the State or Central Government or the local authority.

4. CLAIMS, DISPUTES AND ARBITRATION

4.1 Contractor's Claims

If the Contractor considers himself to be entitled to any extension of the Time for Completion and/or any additional payment, under any Clause of these Conditions or otherwise in connection with the Contract, the Contractor shall give notice to the Engineer, describing the event or circumstance giving rise to the claim. The notice shall be given as soon as practicable, and not

SECTION – 5: CONDITIONS OF CONTRACT(CC) AND SPECIAL CONDITIONS OF CONTRACT (SCC)

later than 28 days after the Contractor became aware, or should have become aware, of the event or circumstance.

If the Contractor fails to give notice of a claim within such period of 28 days, the Time for Completion shall not be extended, the Contractor shall not be entitled to additional payment, and the Employer shall be discharged from all liability in connection with the claim. Otherwise, the following provisions of this Sub-Clause shall apply.

The Contractor shall also submit any other notices which are required by the Contract, and supporting particulars for the claim, all as relevant to such event or circumstance.

The Contractor shall keep such contemporary records as may be necessary to substantiate any claim, either on the Site or at another location acceptable to the Engineer. Without admitting the Employer's liability, the Engineer may, after receiving any notice under this Sub-Clause, monitor the record-keeping and/or instruct the Contractor to keep and provide further contemporary records. The Contractor shall permit the Engineer to inspect all these records, and shall (if instructed) submit copies to the Engineer.

Within 45 days after the Contractor became aware (or should have become aware) of the event or circumstance giving rise to the claim, or within such other period as may be proposed by the Contractor and approved by the Engineer, the Contractor shall send to the Engineer a fully detailed claim which includes full supporting particulars of the basis of the claim and of the extension of time and/or additional payment claimed. If the event or circumstance giving rise to the claim has a continuing effect:

- (a) this fully detailed claim shall be considered as interim;
- (b) the Contractor shall send further interim claims at monthly intervals, giving the accumulated delay and/or amount claimed, and such further particulars as the Engineer may reasonably require; and
- (c) the Contractor shall send a final claim within 28 days after the end of the effects resulting from the event or circumstance, or within such other period as may be proposed by the Contractor and approved by the Engineer.

Within 45 days after receiving a claim or any further particulars supporting a previous claim, or within such other period as may be proposed by the Engineer and approved by the Contractor, the Engineer shall respond with approval, or with disapproval and detailed comments. He may also request any necessary further particulars, but shall nevertheless give his response on the principles of the claim within such fixed period of time.

Each Payment Certificate shall include such amounts for any claim as have been reasonably substantiated as due under the relevant provision of the Contract. Unless and until the particulars supplied are sufficient to substantiate the whole of the claim, the Contractor shall only be entitled to payment for such part of the claim as he has been able to substantiate.

The Engineer shall proceed in accordance with Sub-Clause: [Determinations] to agree or determine (i) the extension (if any) of the Time for Completion (before or after its expiry) in accordance with Sub-Clause: [Extension of Time for Completion], and/or (ii) the additional payment (if any) to which the Contractor is entitled under the Contract.

The requirements of this Sub-Clause are in addition to those of any other Sub-Clause which may apply to a claim. If the Contractor fails to comply with this or another Sub-Clause in relation to any claim, any extension of time and/or additional payment shall take account of the extent (if any) to which the failure has prevented or prejudiced proper investigation of the claim, unless the claim is excluded under the second paragraph of this Sub-Clause.

4.2 Amicable Settlement

In case any dispute between the Engineer and the Contractor for which claim has already been made by the contractor, remains unresolved, the Contractor shall, then, give notice of dissatisfaction and intention to commence arbitration to the Employer duly specifying the subject of the dispute or difference as also the amount of claim item wise. The Parties shall make attempts to settle the dispute amicably before the commencement of arbitration as per procedure set by K-RIDE. However, unless both Parties agree otherwise, demand for arbitration may be made by the Contractor after ninety days from the day on which a notice of dissatisfaction and intention to commence arbitration was given, even if no attempt at amicable settlement has been made.

Procedure for Amicable Settlement in contracts

1. Amicable Settlement Committee at senior management level shall make an attempt to resolve the issues/disputes within 90 days of request by the Contractor.
2. The committee shall comprise of the following: -
 - (i) GM /K-RIDE directly in-charge of the project;
 - (ii) Concerned finance officer, and
 - (iii) GM /K-RIDE (in the same order) directly in-charge of the project of other discipline(s) in case the issues involve other discipline(s) of the engineering
3. Whenever the Contractor submits a request for amicable settlement, MD/K-RIDE should forward the same to concerned GM /K-RIDE (in the same order) directly in-charge of the project. GM /K-RIDE on receipt of the same shall issue a note to the concerned finance officer and concerned GM/K-RIDE of other discipline in case the issues involved other discipline(s) of engineering, about the request for amicable settlement to be dealt by them and fix a date in consultation with them for a hearing. The date should then be communicated to the MD/K-RIDE, GM/ /K-RIDE of other department (if the issues involved their department) and Contractor for presenting their case before the Amicable Settlement Committee.
4. This being an additional workload like arbitration, the Committee members shall be paid fee by K-RIDE at the rates payable to the Arbitrators of K-RIDE.

4.3 Arbitration

Any dispute, in respect of which amicable settlement has not been reached, arising between the Employer and the Domestic or Foreign Contractor related to any matter arising out of or connected with this contract, then the contractor shall be entitled to demand in writing that the dispute or difference be referred to arbitration.

Only such dispute(s) or difference(s) in respect of which the demand had been made for amicable settlement under GCC 4.2 but could not be settled, shall be referred to arbitration.

The Arbitration proceedings shall commence from the day, a written and duly quantified demand for arbitration is received by Managing Director, Rail Infrastructure Development Company (Karnataka) Limited, Bangalore /K-RIDE).

SECTION – 5: CONDITIONS OF CONTRACT(CC) AND SPECIAL CONDITIONS OF CONTRACT (SCC)

The disputes so referred to arbitration shall be settled in accordance with the Indian Arbitration & Conciliation Act, 1996 and any statutory modification or re-enactment thereof.

Any dispute or difference or claim arising out of, or in connection with, or relating to the present contract or the breach, termination or invalidity thereof shall be referred and settled under the Arbitration Centre – Karnataka (Domestic and International) Rules 2012, by one or more arbitrators appointed in accordance with its rules.

4.3.1 Procedure for Appointment of Arbitrators: The arbitrators shall be appointed as per following procedure:

Any dispute or difference or claim arising out of, or in connection with, or relating to the present contract or the breach, termination or invalidity thereof shall be referred and settled under the Arbitration Centre – Karnataka (Domestic and International) Rules 2012, by one or more arbitrators appointed in accordance with its rules.

4.3.2 Arbitration proceedings shall be held at Bangalore, India or at a place where K-RIDE's (dealing the contract) office is located, and the language of the arbitration proceedings and that of all documents and communications between the Parties shall be in English.

4.3.3 Where the Arbitral award is for the payment of money, no interest shall be payable on whole or any part of the money for any period till the date on which the award is made.

4.3.4 The fees and other charges of the conciliator/arbitrators shall be as per the fee structure fixed by the employer with reference to the Rules of Arbitration Centre – Karnataka (Domestic and International) Rules 2012. The cost of arbitration shall be borne equally by the respective parties.

4.3.5 Performance under the contract shall continue during the arbitration proceedings and payments due the Contractor by the Employer shall not be withheld, unless they are the subject matter of the arbitration proceeding.

4.3.6 Excepted matters:

The following are the list of excepted matters in arbitration.

- a. Assistance by Employer for the Stores to be obtained by the Contractor.
- b. Illegal Gratification.
- c. Meaning and intent of specifications and Drawings.
- d. Rates for Non-tendered items of works.
- e. Signing of "No claim Certificate"
- f. Measurement of works.
- g. Provisions of Payment of Wages Act 1936.
- h. Provisions of Contract Labour (Regulation and Abolition) Act, 1970.
- i. Provisions of Employees Compensation Act 1923.
- j. Provisions of Mines Act 1952.
- k. Right of Employer to determine the Contract
- l. Payment on determination of Contract by Employer.

5. JURISDICTION OF COURTS

The Contract Agreement shall be subject to exclusive jurisdiction of Courts as indicated in the Contract Data. . The **Jurisdiction of Courts is Bengaluru, Karnataka**

6. If K-RIDE wishes to engage third party consultants for quality control assessment, apart from the K-RIDE quality control and field tests, the Contractor should co-operate with both Quality control authorities and the third party.
7. Defect liability period will be ONE Year from the date of commercial operations of the Section/Corridor.
8. Royalty Charges shall be recovered as per the prevailing rates by the Department of Mines & Geology, if not paid by the Contractor.
9. As per GO No. CD/300/ LET/ 2006: Dated 18-12-2007, 1% cess will be deducted from the bill as per labour welfare act.
10. All the works are to be carried out as per the Standard specification Issued from time to time.

K-RIDE

SECTION – 6
CONTRACT DATA

INDEX

Table of Contents

SL NO.	DESCRIPTION	PAGE NO.
1	MILE STONE DATES	115-117
2	INSURANCE REQUIREMENT	117
3	TERMS OF PAYMENT	117-119
4	PRICE ADJUSTMENT	119-120

K-RIDE

SECTION 6: CONTRACT DATA

Items marked "N/A" do not apply in this Contract.

The following documents are also part of the Contract:

Clause Reference

- | | |
|--|----------------------|
| <ul style="list-style-type: none"> • The Methodology and Program of Construction | (25 of GCC) |
| <ul style="list-style-type: none"> • Site Investigation Reports | (14 of GCC) |
| <ul style="list-style-type: none"> • The Schedule of Key and Critical Equipment to be deployed on the work as per agreed program of construction. | (3.3 of ITT, 25 GCC) |

The Employer is:

Name: K-RIDE

Address: K-RIDE, Bangalore

(1.1 of GCC)

Name of authorized Representative: K-RIDE

The name and identification number of the Contract: **“Signaling Outdoor and indoor works with Distributed Electronic interlocking (EI) at Yesvantpur Jn. in connection with doubling of Yesvantpur-Channasandra section of Bangalore Division”**.

Tender No: K-RIDE/DL/13/2022, Dated:

Description of Work:

The proposed work is in connection with the doubling work between BYPL-HSRA section of Bengaluru division.

- A. **“Signaling Outdoor and indoor works with Distributed Electronic interlocking (EI) at Yesvantpur Jn. in connection with doubling of Yesvantpur-Channasandra section of Bangalore Division”**.

This bid is for signaling indoor with distributed electronic interlocking and outdoor works at Yesvantpur station.

The start date shall be the date of issue of notice to proceed with the work. [1.1 of GCC]

The Intended Completion Date for the whole of the Works is

18 MONTHS INCLUDING MONSOON with the following milestones - [17, 26 of GCC]

MILESTONE DATES:**Physical works to be completed as per Milestones****i) FOR PORTION: Yesvantpur Outdoor Works**

Key Dates No. (Milestone)	Description of stage (Physical works to be completed)	Uskur station
KD 1	Preparation and approval of outdoor S&T documents like cable route plan, cable core plan, location box details etc	D+50
KD 2	Cable trenching and laying	D+200
KD-3	Location box foundation and signal foundations	D+280
KD 4	Termination of cables/Testing and meggering of cables	D+380
KD 5	Relay wiring, external wiring, alterations.	D+420
KD 6	Site acceptance test	D+480
KD 7	CRS sanction/Availing of disconnection / line block from Railways	D+510
KD 8	Training/compliance to deficiencies/Preparation of As Made documents	D+540
KD 9 (Taking over date)	Hand over from K-RIDE/Take over by Railways	D+545

ii) FOR PORTION: Yesvantpur Indoor Works

Key Dates No. (Milestone)	Description of stage (Physical works to be completed)	BYPL-HSRA and YPR-CSDR section
KD 1	Preparation and approval of indoor S&T documents like SIP, SWR, logic circuits, interface circuits, relay room floor plan etc	D+100
KD 2	Erection of CT rack, Relay racks, MLK and other indoor assets	D+150
KD-3	Relay wiring, internal wiring, alterations, bell test	D+220
KD 4	Factory acceptance test/Square sheet testing	D+250
KD 5	Installation of IPS/LMLA batteries	D+250
KD 6	Erection and installation of SM console/VDU/maintenance PC	D+300
KD 7	Site acceptance test	D+480
KD 8	CRS sanction/Availing of disconnection / line block from Railways	D+510
KD 9	Training/Preparation of As Made documents	D+540
(Taking over date) KD 10	Hand over from K-RIDE/Take over by Railways	D+545

The site is located in Bangalore and the index map drawing is attached.

The Defect Liability period is One year.

The insurance requirement is as below.

SI No.	Type of Cover	Minimum cover for Insurance ³⁶
(i)	Works and Plant and materials	The sum stated in the Agreement
(ii)	Loss or damage to equipment	Full replacement cost
(iii)	Loss or damage to property of Third Party	Full replacement cost
(iv)	Personal injury or death insurance (a) for Third Party	Rs. 20 lakhs. For occurrence without any limit for number of occurrences. The Contractor to take appropriate policy.
	(b) for Contractor's employees or labour	In accordance with the statutory requirements applicable to Govt. of Karnataka.

TERMS OF PAYMENT:

All bills shall be submitted by prime bidder only (to whom contract has been awarded) to the authority mentioned in Preamble.

Subject to any deductions or recovery which the K RIDE may be entitled to make under contract, the Contractor will be entitled to be paid from time to time by way of 'on account payment' for supply of goods and 'progress payment' for works as in the opinion of the Engineer he has executed in terms of Contract.

ON ACCOUNT PAYMENT FOR SUPPLY ITEMS:

"On Account Payment" for supply of equipment, materials will be made on receipt of equipment/materials, as indicated in Schedule **A, B, C, D, E, F, G, H, J, K, L, M & N** by K-RIDE. On Account payments made will subsequently be adjusted against payments due on Provisional Acceptance or Final Acceptance.

90% (Ninety Percent) of the value of each consignment shall be paid on receipt of materials at K-RIDE nominated site duly accepted by the Purchaser's Engineer and on production of the following documents:

- i) Acknowledgement of receipt of materials by Engineer.
- ii) Original Inspection certificates issued by Inspecting Officer.
- iii) Manufacturer's inspection certificate/Warranty Certificate that the materials are in accordance with the specifications of the contract.
- iv) Challan/ Invoice in duplicate.
- v) Indemnity Bond in the approved form (see Section 10).

10% (Ten percent) value of the supply items shall be paid after the successful completion of installation, testing & commissioning of whole system covering all materials and services as per schedule of works and issue of "Provisional Acceptance Certificate" by Engineer.

100% payment against Supply of Spares, Measuring **Instruments**, Tool Kits, and if any similar items, which is not part of installation and commissioning, will be made on receipt of materials, acceptance of the same and production of documents listed in Para 25.3.2 above.

PROGRESS PAYMENT FOR EXECUTION ITEMS:

Progress payment shall be made separately for each pure execution item/ sub-item of work given in the schedule **A, B, C, D, E, F, G, H, J, K, L, M & N** as follows.

75% (Seventy five percent) of the progress payment for the items in schedule of work for trenching and protective works and cable laying activities shall be made (cable trenching, refilling, laying of cables, cable trench on bridges/culverts). The balance **15% (Fifteen percent)** of the progress payment for these items shall be made after terminations and end to end testing from relay room to function end are completed and jointly tested by the Engineer to his satisfaction.

For all other items of work (**schedule A, B, C, D, E, F, G, H, J, K, L, M & N**), progress payment for **90% (ninety percent)** value of the work/ services will be made after the works are completed to full satisfaction of K RIDE.

10% value of the works/ services completed shall be made after the issue of Provisional Acceptance Certificate and submission of all 'As made' documents of the relevant schedules.

ON ACCOUNT PAYMENT FOR SUPPLY AND INSTALLATION ITEMS:

'On Account' payments in respect of items involving supply and installation, **75%** of the accepted rate of the schedule item will be paid on complete supply of the equipment listed in the schedule after due inspection, against production of indemnity bond and other formalities as applicable to other supply items in the schedule. The remaining **15%** payment will be released only after successful installation of the equipment under the schedule. The balance **10%** will be released on submission of all 'As made' documents of the relevant schedule.

FINAL PAYMENT:

On the basis of provisional acceptance certificate issued by the Engineer for all the works in all the sections covered in this contract, the final bill for the balance payment for each item/sub-item of work shall be submitted by the Contractor along with a clear "NO CLAIM CERTIFICATE". The provisional acceptance certificate shall be issued by the Engineer only when he has accepted the work wholly after conducting the acceptance tests on each item of work.

FINAL SETTLEMENT:

On expiry of the warranty period and issue of certificate by Engineer-in-charge regarding satisfactory completion of work and final acceptance of the entire installations in all respect, **Performance Guarantee/Security Deposit** will be released to the Contractor after adjustment of any dues payable by the contractor.

DEDUCTION FROM ON ACCOUNT PAYMENT BILLS

All costs, damages or expenses, which K-RIDE may have paid or incurred, which under the provisions of contract are Contractor's obligations, will be deducted by K-RIDE from progress payment bills/invoice of Contractor, as and when it is understood that such an expense have been incurred or paid for.

All such claims of K-RIDE shall, however, be duly supported by appropriate and certified vouchers, receipts or explanations as are available to enable the Contractor to identify such claims.

PRICE ADJUSTMENT: Applicable for schedules**CHANGE IN COSTS - PRICE ADJUSTMENT**

PRICE ADJUSTMENT CLAUSE FOR WORKS CONTRACTS: Refer Particular Conditions of Contract, Clause: Price adjustment clause

The liquidated damages for the whole of the works are

The liquidity damages for each Key dates/milestone is 0.001% of total contract price per day of delay for not achieving the Key Date/ Milestone. The maximum amount of liquidated damages for the whole of the works is Ten percent of final contract price: [GCC 41]

The amounts of the advance payment are : [GCC 42]

Nature of Advance	Amount Rs.	Conditions to be fulfilled
Mobilization	5% of the contract price (In Two Installments)	On submission of unconditional bank guarantee (further details are in Particular conditions of contract)

(The advance payment will be paid to the contractor no later than 30 days after fulfillment of the above condition.)

Repayment of advance payment for mobilization:

The recovery of the Mobilization and Plant and Machinery Advances shall be made from each bill in equal monthly instalments commencing after 15% of contract value is billed and recovery to be completed within 85% of the contract value and the recovery shall be made at the rate 10% of the amount the Interim payment certificate until such time as loan has been repaid, always provided that the loan shall be completely repaid prior to the expiry of the original time for completion pursuant to Clauses 17 and 26. The date by which "as-built" drawings (in suitable scale) in 2 sets are required is within 30 days of issue of certificate of completion of Whole or Section of the Work as the case may be. [GCC 48]

The following events shall also be fundamental breach of the contract: [GCC 49.2]

The contractor has contravened Sub-clause 7.1 and Clause 9 of Condition of contract.

The percentage to apply to the value of the work not completed representing the Employer's **30%** [GCC 50.1]

Jurisdiction of Courts :

Jurisdiction of Courts is Bengaluru, Karnataka

K-RIDE

SECTION-7
**PARTICULAR CONDITIONS OF
CONTRACT (PCC)**

BLANK PAGE

K-RIDE

PARTICULAR CONDITIONS OF CONTRACT (PCC)

The following Particular Conditions of Contract (PCC) shall supplement the Conditions of Contract (CC)/GCC/SCC/Contract Data. Whenever there is a conflict, the provisions herein shall prevail over those in the CC/GCC/SCC/Contract Data. The conditions indicated in PCC will be on priority as compared to the conditions of CC/GCC/SCC/Contract Data.

CC/SCC REFERENCE CLAUSE	DESCRIPTION
Clause-1/CC Definitions	<p>The following paras are added to the Existing CC Clauses.</p> <p>“Contract Agreement” The Parties shall enter into a Contract Agreement within 28 days after the Contractor receives the Letter of Acceptance, unless they agree otherwise.</p> <p>“Letter of Acceptance” means the letter of formal acceptance, signed by the Employer, of the Letter of Bid, including any annexed memoranda comprising agreements between and signed by both Parties. If there is no such letter of acceptance, the expression “Letter of Acceptance” means the Contract Agreement and the date of issuing or receiving the Letter of Acceptance means the date of signing the Contract Agreement.</p> <p>“Letter of Bid” means the document entitled letter of bid, which was completed by the Contractor and includes the signed offer to the Employer for the Works.</p> <p>“Drawings” means the drawings of the Works, as included in the Contract, and any additional and modified drawings issued by (or on behalf of) the Employer in accordance with the Contract.</p> <p>“Schedules” means the document(s) entitled schedules, completed by the Contractor and submitted with the Letter of Bid, as included in the Contract. Such document may include the Bill of Quantities, data, lists, and schedules of rates and/or prices.</p> <p>“Bid/Tender” means the Letter of Technical Bid and Letter of Price Bid and all other documents which the Contractor submitted with the Letter of Technical Bid and Letter of Price Bid, as included in the Contract.</p> <p>“Employer’s Requirements” means the document entitled ‘Employer’s Requirements’ as part of Works Requirements and as included in the Contract, and any additions and modifications to such document in accordance with the Contract. Such document specifies the purpose, scope, and/or design and/or other technical criteria, for the works.</p> <p>Parties and Persons</p> <p>“Party” means the Employer or the Contractor, as the context requires.</p> <p>“Engineer” means the person nominated by the Employer to act as the Engineer for the purposes of the Contract and named in the Contract Data, or other person appointed from time to time by the Employer and notified to the Contractor under New-Clause 3.4 [Replacement of the Engineer]. The person nominated to act as an engineer may be an employee of Rail Infrastructure Development Company (Karnataka) Ltd (K-RIDE) or an employee of a Project Management Consultancy firm engaged by K-RIDE for project management as per the discretion of the Employer.</p> <p>“Contractor’s Representative” means the person named by the Contractor in the Contract or appointed from time to time by the Contractor under New-Clause 4.3 [Contractor’s Representative], who acts on behalf of the Contractor.</p>

“Employer’s Representative” means the person named by the Employer in the Contract or appointed from time to time by the Employer who acts on behalf of the Employer.

“Employer’s Personnel” means the Engineer, the assistants referred to in New-Clause 3.2 [Delegation by the Engineer] and all other staff, labour and other employees of the Engineer and of the Employer; and any other personnel notified to the Contractor, by the Employer or the Engineer, as Employer’s Personnel.

“Contractor’s Personnel” means the Contractor’s Representative and all personnel whom the Contractor utilises on Site, who may include the staff, labour and other employees of the Contractor and of each Subcontractor; and any other personnel assisting the Contractor in the execution of the Works.

“Base Date” means the date 28 days prior to the deadline for submission of bids.

“Tests on Completion” means the tests which are specified in the Contract or agreed by both Parties or instructed as a Variation, and which are carried out under Clause 30 [Tests on Completion] before the Works or a Section (as the case may be) are taken over by the Employer.

“Day” means any (working or non-working) calendar day from 00:00 hrs. to 24:00 hrs.

“Time Periods” Any reference to time period commencing “from” the specified day or date “till” or “until” a specified day shall include both such days.

Any reference to **“Time”** shall be according to Indian Standard Time (IST).

Money and Payments

“Accepted Contract Amount” means the amount accepted in the Letter of Acceptance for the execution and completion of the Works and the remedying of any defects. In the Letter of Acceptance, the Accepted Contract Amount shall have two components i.e. (i) the base amount excluding GST (ii) GST component (calculated at the rate for works contract service as per GST Laws).

“Cost” means all expenditure reasonably incurred (or to be incurred) by the Contractor, whether on or off the Site, including overhead and similar charges, but does not include profit.

“Final Statement” means the statement defined in Sub-Clause 37.12 [Application for Final Payment Certificate].

“Foreign Currency” means a currency in which part (or all) of the Contract Price is payable, but not the Local Currency.

“Local Currency” means the currency in Indian Rupees.

“Statement” means a statement submitted by the Contractor as part of an application, under Clause 37 and 40 [Contract Price and Payment], for a payment certificate

Works and Goods

“Contractor’s Equipment” means all apparatus, machinery, vehicles and other things required for the execution and completion of the Works and the remedying of any defects. However, Contractor’s Equipment excludes Temporary Works, Employer’s Equipment (if any), Plant, Materials and any other things intended to form or forming part of the Permanent Works.

	<p>“Goods” means Contractor’s Equipment, Materials, Plant and Temporary Works, or any of them as appropriate.</p> <p>“Permanent Works” means the permanent works to be executed by the Contractor under the Contract.</p> <p>“Section” means a part of the Works specified in the Contract Data as a Section (if any).</p> <p>“Temporary Works” means all temporary works of every kind (other than Contractor’s Equipment) required on Site for the execution and completion of the Permanent Works and the remedying of any defects.</p> <p>Other Definitions</p> <p>“Contractor’s Documents” means the calculations, computer programs and other software, drawings, manuals, models and other documents of a technical nature (if any) supplied by the Contractor under the Contract.</p> <p>“Country” means India, the country in which the Site (or most of it) is located, where the Permanent Works are to be executed.</p> <p>“Employer’s Equipment” means the apparatus, machinery and vehicles (if any) made available by the Employer for the use of the Contractor in the execution of the Works, as stated in the Specification; but does not include Plant which has not been taken over by the Employer.</p> <p>“Laws” means all national (or state) legislation, statutes, ordinances and other laws, and regulations and by-laws of any legally constituted public authority.</p> <p>“Site” means the places where the Permanent Works are to be executed and to which Plant and Materials are to be delivered, and any other places as may be specified in the Contract as forming part of the Site.</p> <p>“Unforeseeable” means not reasonably foreseeable and against which adequate preventive precautions could not reasonably be taken by an experienced contractor by the date for submission of the Bid.</p> <p>“Railway” means a railway, or any portion of a railway for public carriage of passengers and goods as defined in the Railways ACT 1989. Any reference to railway means the Indian Railways and the respective Zonal Railway</p>
<p>Clause-1/CC</p>	<p>The following paras are added to the Existing CC Clauses.</p> <p>Employers Name and Address: K-RIDE (Rail Infrastructure Development Company (Karnataka) Limited) (A Joint venture of GoK and MoR) #8 , 1st Floor, Samparka Soudha, Dr. Rajkumar Road, Opposite Orion Mall Rajaji Nagar 1st Block Bangalore – 560010 Tele: +91 6364890850</p> <p>Employers Representative and address: General Manager/S&T K-RIDE, K-RIDE (Rail Infrastructure Development Company (Karnataka) Limited) #8, 1st Floor, Samparka Soudha,</p>

	<p>Dr. Rajkumar Road, Opposite Orion Mall Rajaji Nagar 1st Block Bangalore – 560010 Tele: +91 6364890850 E – Mail: gmst@kride.in, s.nageswararao.kride@ka.gov.in</p>
Clause -2.1/CC Interpretation.	<p>The following paras are added to the Existing CC Clauses.</p> <p>(a) provisions including the word “agree,” “agreed” or “agreement” require the agreement to be recorded in writing;</p> <p>(b) “written” or “in writing” means hand-written, type-written, printed or electronically made, and resulting in a permanent record; and</p> <p>(c) the word “tender” is synonymous with “bid”, and “tenderer” with “bidder” and the words “tender documents” with “bidding documents”</p>
Clause-2.2/CC. Priority of Documents	<p>Replace the existing sub clause 2.2 of CC</p> <p>The documents forming the Contract are to be taken as mutually explanatory of one another. For the purposes of interpretation, the priority of the documents shall be in accordance with the following sequence:</p> <ol style="list-style-type: none"> 1. Contract Agreement (if any), 2. Letter of Acceptance, notice to proceed to works, 3. Letter of bid/Contractor tender, 4. Addendum/Corrigendum including Reply to pre bid queries, 5. Schedules (including Priced Bill of Quantities), 6. Particular Conditions of Contract, 7. Conditions of Contract/SCC and Contract Data 8. Works/Employer’s Requirements, 9. Technical Specifications, 10. Drawings, 11. any other documents forming part of the Contract. <p>If an ambiguity or discrepancy is found in the documents, the Engineer shall issue necessary clarification or instruction.</p>
Clause-6.1/CC, Communications	<p>The following para is added to the existing CC clause:</p> <p>Wherever these Conditions provide for the giving or issuing of approvals, certificates, consents, determinations, notices, requests and discharges, these communications shall be: in writing and delivered by hand (against receipt), sent by mail or courier, or transmitted using any of the agreed systems of electronic transmission as stated in the Contract Data; and delivered, sent or transmitted to the address for the recipient’s communications as stated in the Contract Data.</p>
Clause- 7/CC	<p>The following paras are added to the Existing CC Clauses.</p> <p>7.1 Definition of nominated Subcontractor</p> <p>In the Contract, “nominated Subcontractor” means a Subcontractor:</p> <p>(a) who is stated in the Contract as being a nominated Subcontractor, or</p>

- (b) whom the Engineer, under Clause 7/CC [Sub-contracting], instructs the Contractor to employ as a Subcontractor.

Sub-contractors

The Contractor shall not subcontract the whole of the Works. The Contractor shall be responsible for the acts or defaults of any Subcontractor, his agents or employees, as if they were the acts or defaults of the Contractor.

Unless otherwise stated in the Conditions of Contract:

- (a) The Contractor shall not be required to obtain consent to suppliers solely of Materials, or to a subcontract for which the Subcontractor is named in the Contract or as specifically provided in the Contract data or value of any sub-contract for Works, provided that such works are not for the key activities.
- (b) The prior consent of the Engineer shall be obtained to other proposed Subcontractors and/or suppliers. While submitting his proposal in this regard, the Contractor shall ensure that;
- (i) Total value of Works requiring such consent for subcontracting shall not be more than 50% (fifty per cent) of the Contract Price;
 - (ii) The proposed subcontractor must have executed works of 40% of value of the proposed subcontract through a single contract during last seven years; and
 - (iii) No banning/blacklisting/declaration as poor performer by K-RIDE is in force on the proposed subcontractor (on the date of grant of consent by the Engineer);
 - (iv) No contract of the proposed subcontractor has been terminated by K-RIDE during the last two years (to be reckoned from the date of grant of consent by the Engineer);
 - (v) The Contractor shall submit the proposal for subcontracting with the name, particulars and the relevant experience of the proposed subcontractor.
- (c) The Contractor shall give the Engineer not less than 28 days' notice of the intended date of the commencement of each Subcontractor's work, and of the commencement of such work on the Site;
- (d) Each subcontract shall include provisions which would entitle the Employer to require the subcontract to be assigned to the Employer under New-Clause 4.23/PCC [Assignment of Benefit of Subcontract] (if or when applicable) or in the event of termination under Sub-Clause 49.7/PCC. [Termination by Employer]; and
- (e) On getting consent from the Engineer, the Contractor shall provide to the Engineer copy of the agreement entered with such subcontractor.

The Contractor shall ensure that the requirements imposed on the Contractor by New-Clause 1.6/PCC [Confidential Details] apply equally to each Subcontractor.

Where practicable, the Contractor shall give fair and reasonable opportunity for contractors from the Country to be appointed as Subcontractors.

The Contractor shall endeavor to resolve all matters and payments amicably and speedily with the sub-contractors.

The Contractor shall indemnify and hold the Employer harmless against and from any claim of subcontractors or suppliers of the materials.

The Contractor shall release payment to the Sub-contractors/Suppliers promptly and shall endeavor to resolve all issues amicably and speedily with the Sub-contractors/Suppliers, so that the execution of work is not affected in any manner whatsoever.

In case a Sub-contractor/Supplier represents to the Engineer in writing with supporting documents, stating that he has not received payment due as per the agreement/work or purchase order for the works executed by such Sub-contractor or supplies made by such Supplier, which have been covered in previous Payment Certificates and the Engineer finds such representation having merit, the Engineer, before issuing next Payment Certificate, may forward a copy of the representation to the Contractor requesting the Contractor to supply reasonable evidence that the amount stated to be outstanding by the Sub-contractor/Supplier for the works executed or supplies made, which have been covered in previous Payment Certificates has been paid and if not, why the same is not payable. The Engineer may recommend to make payment to the Sub-contractor/Supplier unless the Contractor submits reasonable evidence to the Engineer:

- (i) that the amount claimed has been paid, or
- (ii) satisfying the Engineer in writing that the Contractor is entitled to withhold or that the amount is not payable.

On the recommendation of the Engineer, the Employer may (at his sole discretion) directly pay to the Sub-contractor/Supplier the amount due for and on behalf of the Contractor, part or all of such amounts previously certified (less applicable deductions) as are found due to the Sub-contractor/Supplier by the Engineer. The Employer shall adjust the amount paid directly to the Sub-contractor/Supplier from any amount due by it to the Contractor. The Contractor shall repay the amount, in case no amount is found due by the Employer to the Contractor.

That the payment by Employer, on behalf of the Contractor to its Sub-contractor/Supplier, shall not alter any terms of agreement between the Employer and the Contractor and nor the same shall result in any privity of contract between the Employer and the Sub-contractor/Supplier.

Assignment of Contractor's and Sub-contractor's Obligations:

The Contractor shall not assign a right or benefit under the Contract without first obtaining Employer's prior written consent, otherwise than by:

- A. a charge in favor of the Contractor's bankers of any money due or to become due under the Contract, or
- B. assignment to the Contractor's insurers (in cases where the insurers have discharged the Contractor's loss or liability) of the Contractor's right to obtain relief against any other party liable.

If a Subcontractor's obligations extend beyond the expiry date of Defects Liability Period, then the Contractor shall assign the benefits of such obligations to the Employer.

In the event that a sub-contractor of any tier provides to the Contractor or any other sub-contractor a warranty in respect of Plant, Materials or services supplied in connection with the Works, or undertakes a continuing obligation of any nature whatsoever in relation to such Plant, Materials or services (including without limitation an obligation to maintain stocks of spare parts) extending for a period exceeding that of the Defects Liability Period or where there is more than one Defects Liability Period exceeding that of the latest Defects Liability Period, and if the Engineer so directs in writing within 21 days of the expiry of the Defects Liability Period or the latest Defects Liability Period (as the case may be), the Contractor shall immediately assign or

obtain the assignment of the benefit of such warranty or obligation to the Employer or at the direction of the Employer, to any third party.

Specialist Subcontracting

If an Applicant intends to subcontract any highly specialized elements of the Works to specialist subcontractors, such elements and the proposed subcontractors shall be clearly identified, and the experience and capacity of the subcontractors shall be described in the relevant Information Forms.

Acceptable Substitutes

With reference to subcontracting & specialist subcontracting, the Employer may require Applicants to provide more information about their proposals. If any proposed subcontractor is found ineligible or unsuitable to carry out an assigned task, the Employer may request the Applicant to propose an acceptable substitute, and may conditionally pre-qualify the Applicant accordingly, before issuing an invitation to tender.

7.2 Objection to Nomination

The Contractor shall not be under any obligation to employ a nominated Subcontractor against whom the Contractor raises reasonable objection by notice to the Engineer as soon as practicable, with supporting particulars. An objection shall be deemed reasonable if it arises from (among other things) any of the following matters, unless the Employer agrees to indemnify the Contractor against and from the consequences of the matter:

- (a) there are reasons to believe that the Subcontractor does not have sufficient competence, resources or financial strength;
- (b) the subcontract does not specify that the nominated Subcontractor shall indemnify the Contractor against and from any negligence or misuse of Goods by the nominated Subcontractor, his agents and employees; or
- (c) the subcontract does not specify that, for the subcontracted work (including design, if any), the nominated Subcontractor shall:
 - (i) undertake to the Contractor such obligations and liabilities as will enable the Contractor to discharge his obligations and liabilities under the Contract, and
 - (ii) Indemnify the Contractor against and from all obligations and liabilities arising under or in connection with the Contract and from the consequences of any failure by the Subcontractor to perform these obligations or to fulfil these liabilities.

7.3 Payments to nominated Subcontractors

The Contractor shall pay to the nominated Subcontractor the amounts which the Engineer certifies to be due in accordance with the subcontract. These amounts plus other charges shall be included in the Contract Price in accordance with sub-paragraph (b) of Sub-Clause 34.5/PCC [Provisional Sums], except as stated in Sub-Clause 7.4/PCC [Evidence of Payments].

7.4 Evidence of Payments

Before issuing a Payment, Certificate which includes an amount payable to a nominated Subcontractor, the Engineer may request the Contractor to supply reasonable evidence that the nominated Subcontractor has received (Within 7 days of receipt of previous payment by the contractor) all amounts due in accordance with previous Payment Certificates, less

	<p>applicable deductions for retention or otherwise. Unless the Contractor, submits this reasonable evidence to the Engineer, or</p> <ul style="list-style-type: none"> (i) satisfies the Engineer in writing that the Contractor is reasonably entitled to withhold or refuse to pay these amounts, and (ii) submits to the Engineer reasonable evidence that the nominated Subcontractor has been notified of the Contractor's entitlement, <p>then the Employer may (at his sole discretion) pay, direct to the nominated Subcontractor, part or all of such amounts previously certified (less applicable deductions) as are due to the nominated Subcontractor and for which the Contractor has failed to submit the evidence described in sub-paragraphs (a) or (b) above. The Contractor shall then repay, to the Employer, the amount which the nominated Subcontractor was directly paid by the Employer.</p> <p>7.5 Assignment of Benefit of Subcontract</p> <p>If a Subcontractor's obligations extend beyond the expiry date of the relevant Defects Notification Period and the Engineer, prior to this date, instructs the Contractor to assign the benefit of such obligations to the Employer, then the Contractor shall do so. Unless otherwise stated in the assignment, the Contractor shall have no liability to the Employer for the work carried out by the Subcontractor after the assignment takes effect.</p>
<p>Clause11/CC</p>	<p>The following paras are added to the Existing CC Clauses.</p> <p>Risk and Responsibility</p> <p>11.1 Indemnities</p> <p>The Contractor shall indemnify and hold harmless the Employer, the Employer's Personnel, Employers Representative and their respective agents, against and from all claims, damages, losses and expenses (including legal fees and expenses) in respect of:</p> <ul style="list-style-type: none"> (a) bodily injury, sickness, disease or death, of any person including railway user whatsoever arising out of or in the course of or by reason of the Contractor's design (if any), the execution and completion of the Works and the remedying of any defects, unless attributable to any negligence, wilful act or breach of the Contract by the Employer, the Employer's Personnel, or any of their respective agents, and (b) damage to or loss of any property, real or personal (other than the Works), to the extent that such damage or loss arises out of or in the course of or by reason of the Contractor's design (if any), the execution and completion of the Works and the remedying of any defects, unless and to the extent that any such damage or loss is attributable to any negligence, wilful act or breach of the Contract by the Employer, the Employer's Personnel,, their respective agents, or anyone directly or indirectly employed by any of them. <p>The Employer shall indemnify and hold harmless the Contractor, the Contractor's Personnel, and their respective agents, against and from all claims, damages, losses and expenses (including legal fees and expenses) in respect of (1) bodily injury, sickness, disease or death, which is attributable to any negligence, wilful act or breach of the Contract by the Employer, the Employer's Personnel, or any of their respective agents, and (2) the matters for which liability may be excluded from insurance cover, as described in sub-paragraphs (d)(i), (ii) and (iii) of Sub-Clause 13.8/PCC [Insurance Against Injury to Persons and Damage to Property].</p>

11.2 Contractor's Care of the Works

The Contractor shall take full responsibility for the care of the Works and Goods from the Commencement Date until the Taking-Over Certificate is issued (or is deemed to be issued under Sub-Clause 46.1/PCC [Taking Over of the Works and Sections]) for the Works, when responsibility for the care of the Works shall pass to the Employer. If a Taking-Over Certificate is issued (or is so deemed to be issued) for any Section or part of the Works, responsibility for the care of the Section or part shall then pass to the Employer.

After responsibility has accordingly passed to the Employer, the Contractor shall take responsibility for the care of any work which is outstanding on the date stated in a Taking-Over Certificate, until this outstanding work has been completed.

If any loss or damage happens to the Works, Goods or Contractor's Documents during the period when the Contractor is responsible for their care, from any cause not listed in Sub-Clause 11.3/PCC [Employer's Risks], the Contractor shall rectify the loss or damage at the Contractor's risk and cost, so that the Works, Goods and Contractor's Documents conform with the Contract.

The Contractor shall be liable for any loss or damage caused by any actions performed by the Contractor after a Taking-Over Certificate has been issued. The Contractor shall also be liable for any loss or damage which occurs after a Taking-Over Certificate has been issued and which arose from a previous event for which the Contractor was liable.

11.3 Employer's Risks

Clause 11 of CC and clause 38 of CC are substituted with clause 11.3 of PCC as below:

The risks referred to herein below, in so far as they directly affect the execution of the works in the Country, are:

- (a) war, hostilities (whether war be declared or not), invasion, act of foreign enemies,
- (b) rebellion, terrorism, sabotage by persons other than the Contractor's Personnel, revolution, insurrection, military or usurped power, or civil war, within the Country,
- (c) riot, commotion or disorder within the Country by persons other than the Contractor's Personnel,
- (d) munitions of war, explosive materials, ionising radiation or contamination by radio-activity, within the Country, except as may be attributable to the Contractor's use of such munitions, explosives, radiation or radio-activity,
- (e) pressure waves caused by aircraft or other aerial devices travelling at sonic or supersonic speeds,
- (f) use or occupation by the Employer of any part of the Permanent Works, except as may be specified in the Contract, and
- (g) design of any part of the Works by the Employer's Personnel or by others for whom the Employer is responsible.

11.4 Consequences of Employer's Risks:

If and to the extent that any of the risks listed in Sub-Clause 11.3/PCC above results in loss or damage to the Works, Goods or Contractor's Documents, the Contractor shall promptly give notice to the Engineer and shall rectify this loss or damage to the extent required by the Engineer.

If the Contractor suffers delay and/or incurs Cost from rectifying this loss or damage, the Contractor shall give a further notice to the Engineer and shall be entitled subject to Sub-Clause 4.1/SCC [Contractor's Claims] to:

- (a) an extension of time for any such delay, if completion is or will be delayed, under Sub-Clause [Extension of Time for Completion], and
- (b) In the case of sub-paragraphs (f) and (g) of Sub-Clause 11.3/PCC [Employer's Risks], Cost shall be payable.

After receiving this further notice, the Engineer shall proceed in accordance with New-Clause 3.5/PCC [Determinations] to agree or determine these matters.

11.5 Intellectual and Industrial Property Rights

In this Sub-Clause, "infringement" means an infringement (or alleged infringement) of any patent, registered design, copyright, trade mark, trade name, trade secret or other intellectual or industrial property right relating to the Works; and "claim" means a claim (or proceedings pursuing a claim) alleging an infringement.

Whenever a Party does not give notice to the other Party of any claim within 28 days of receiving the claim, the first Party shall be deemed to have waived any right to indemnity under this Sub-Clause.

The Employer shall indemnify and hold the Contractor harmless against and from any claim alleging an infringement which is or was:

- (a) an unavoidable result of the Contractor's compliance with the Contract, or
- (b) a result of any Works being used by the Employer:
 - (i) for a purpose other than that indicated by, or reasonably to be inferred from, the Contract, or
 - (ii) in conjunction with anything not supplied by the Contractor, unless such use was disclosed to the Contractor prior to the Base Date or is stated in the Contract.

The Contractor shall indemnify and hold the Employer harmless against and from any other claim which arises out of or in relation to (i) the manufacture, use, sale or import of any Goods, or (ii) any design for which the Contractor is responsible.

If a Party is entitled to be indemnified under this Sub-Clause, the indemnifying Party may (at its cost) conduct negotiations for the settlement of the claim, and any litigation or arbitration which may arise from it. The other Party shall, at the request and cost of the indemnifying Party, assist in contesting the claim. This other Party (and its Personnel) shall not make any admission which might be prejudicial to the indemnifying Party, unless the indemnifying Party failed to take over the conduct of any negotiations, litigation or arbitration upon being requested to do so by such other Party.

	<p>11.6 Limitation of Liability</p> <p>Neither Party shall be liable to the other Party for loss of use of any Works, loss of profit, loss of any contract or for any indirect or consequential loss or damage which may be suffered by the other Party in connection with the Contract, provided that this exclusion shall not apply to any obligation of the Contractor to pay Delay Damages to the Employer under Sub-Clause 26.6/PCC [Delay Damages].</p> <p>The total liability of the Contractor to the Employer, under or in connection with the Contract other than under New-Clause 4.37/PCC [Electricity, Water and Gas], New Clause 4.38/PCC [Employer's Equipment and Free-Issue Material], Sub-Clause 11.1/PCC [Indemnities] and Sub-Clause 11.5/PCC [Intellectual and Industrial Property Rights], shall not exceed the sum as specified in the Contract Data or if nothing is specified in the Contract Data, the accepted Contract Amount.</p> <p>This Sub-Clause shall not limit liability in any case of fraud, deliberate default or reckless misconduct by the defaulting Party.</p> <p>Maximum total liability of Contractor is accepted contract amount.</p> <p>11.7 Use of Employer's Accommodation/ Facilities</p> <p>The Contractor shall take full responsibility for the care of the Employer provided accommodation and facilities, if any, as detailed in the Specification, from the respective dates of hand-over to the Contractor until cessation of occupation (where hand-over or cessation of occupation may take place after the date stated in the Taking-Over Certificate for the Works).</p> <p>If any loss or damage happens to any of the above items while the Contractor is responsible for their care arising from any cause whatsoever other than those for which the Employer is liable, the Contractor shall, at his own cost, rectify the loss or damage to the satisfaction of the Engineer.</p>
<p>Clause 13/CC</p>	<p>The following paras are added to the Existing CC Clauses.</p> <p>INSURANCE</p> <p>13.6 General Requirements for Insurances</p> <p>In this Clause, "insuring Party" means, for each type of insurance, the Party responsible for effecting and maintaining the insurance specified in the relevant Sub-Clause.</p> <p>Wherever the Contractor is the insuring Party, each insurance shall be effected with insurers and in terms approved by the Employer. These terms shall be consistent with any terms agreed by both Parties before the date of the Letter of Acceptance. This agreement of terms shall take precedence over the provisions of this Clause.</p> <p>If a policy is required to indemnify joint insured, the cover shall apply separately to each insured as though a separate policy had been issued for each of the joint insured. If a policy indemnifies additional joint insured, namely in addition to the insured specified in this Clause, (i) the Contractor shall act under the policy on behalf of these additional joint insured except that the Employer shall act for Employer's Personnel, (ii) additional joint insured shall not be entitled to receive payments directly from the insurer or to have any</p>

other direct dealings with the insurer, and (iii) the insuring Party shall require all additional joint insured to comply with the conditions stipulated in the policy.

Periods for submission of insurance:

- a) evidence of insurance: Before start date of work.
- b) relevant policies: Before start date of work.

Each policy insuring against loss or damage shall provide for payments to be made in the currencies required to rectify the loss or damage. Payments received from insurers shall be used for the rectification of the loss or damage.

The relevant insuring Party shall, within the respective periods stated in the Contract Data (calculated from the Commencement Date), submit to the other Party:

- (a) evidence that the insurances described in this Clause have been effected, and
- (b) copies of the policies for the insurances described in Sub-Clause 13.7/PCC [Insurance for Works and Contractor's Equipment] and Sub-Clause 13.8/PCC [Insurance against Injury to Persons and Damage to Property].
- (c) If the contractor fails to submit evidence and copies of the policies as mentioned in (a) & (b) above to prove that the policies have been obtained within the period specified in the contract data, and submits the same later on and from the submitted evidence it is found that the policies have not been obtained within the period specified, the Employer shall recover double the cost of the premium for the period the policies have been delayed.

When each premium is paid, the insuring Party shall submit evidence of payment to the other Party. Whenever evidence or policies are submitted, the insuring Party shall also give notice to the Engineer.

Each Party shall comply with the conditions stipulated in each of the insurance policies. The insuring Party shall keep the insurers informed of any relevant changes to the execution of the Works and ensure that insurance is maintained in accordance with this Clause.

Neither Party shall make any material alteration to the terms of any insurance without the prior approval of the other Party. If an insurer makes (or attempts to make) any alteration, the Party first notified by the insurer shall promptly give notice to the other Party.

If the insuring Party fails to effect and keep in force any of the insurances it is required to effect and maintain under the Contract, or fails to provide satisfactory evidence and copies of policies in accordance with this Sub-Clause, the other Party may (at its option and without prejudice to any other right or remedy) effect insurance for the relevant coverage and pay the premiums due. The insuring Party shall pay double the amount of these premiums to the other Party, and the Contract Price shall be adjusted accordingly.

Nothing in this Clause limits the obligations, liabilities or responsibilities of the Contractor or the Employer, under the other terms of the Contract or otherwise. Any amounts not insured or not recovered from the insurers shall be borne by the Contractor and/or the Employer in accordance with these obligations, liabilities or responsibilities. However, if the insuring Party fails to effect and keep in force an insurance which is available and which it is required to effect and maintain under the Contract, and the other Party neither approves

the omission nor effects insurance for the coverage relevant to this default, any moneys which should have been recoverable under this insurance shall be paid by the insuring Party.

Payments by one Party to the other Party shall be subject to New-Clause 2.4/PCC [Employer's Claims] or Sub-Clause 4.1/SCC [Contractor's Claims], as applicable.

The Contractor shall be entitled to place all insurance relating to the Contract (including, but not limited to the insurance referred to Clause 13/CC/PCC with insurers from any eligible source country.

13.7 Insurance for Works and Contractor's Equipment

The Contractor shall insure the Works, Plant, Materials, including those issued by the Employer and Contractor's Documents for not less than the full reinstatement cost including the costs of demolition, removal of debris and professional fees and profit, subject to a maximum value indicated in Contract Data. This insurance shall be effective from the date by which the evidence is to be submitted under sub-paragraph (a) of Sub-Clause 13.6/PCC [General Requirements for Insurances], until the date of issue of the Taking-Over Certificate for the Works.

The insuring Party shall maintain this insurance to provide cover until the date of issue of the Performance Certificate, for loss or damage for which the Contractor is liable arising from a cause occurring prior to the issue of the Taking-Over Certificate, and for loss or damage caused by the Contractor in the course of any other operations (including those under New-Clause 6/PCC [Defects Liability]).

The insuring Party shall insure the Contractor's Equipment for not less than the full replacement value, including delivery to Site. For each item of Contractor's Equipment, the insurance shall be effective while it is being transported to the Site and until it is no longer required as Contractor's Equipment.

Unless otherwise stated in the Conditions of Contract/SCC, insurances under this Sub-Clause:

- (a) shall be effected and maintained by the Contractor as insuring Party,
- (b) shall be in the joint names of the Parties, who shall be jointly entitled to receive payments from the insurers, payments being held or allocated between the Parties for the sole purpose of rectifying the loss or damage,
- (c) shall cover all loss and damage from any cause not listed in Sub-Clause 11.3/PCC [Employer's Risks],
- (d) shall also cover loss or damage to a part of the Works which is attributable to the use or occupation by the Employer of another part of the Works, and loss or damage from the risks listed in sub-paragraphs (c), (g) and (h) of Sub-Clause 11.3/PCC [Employer's Risks], excluding (in each case) risks which are not insurable at commercially reasonable terms, with deductibles per occurrence of not more than the amount stated in the Contract Data (if an amount is not so stated, this sub-paragraph (d) shall not apply), and
- (e) may however exclude loss of, damage to, and reinstatement of:
 - i) part of the Works which is in a defective condition due to a defect in its design, materials or workmanship (but cover shall include any other parts which are lost or

damaged as a direct result of this defective condition and not as described in sub-paragraph (ii) below),

- ii) a part of the Works which is lost or damaged in order to reinstate any other part of the Works if this other part is in a defective condition due to a defect in its design, materials or workmanship,
- iii) a part of the Works which has been taken over by the Employer, except to the extent that the Contractor is liable for the loss or damage, and
- iv) [DELETED]

If, more than one year after the Base Date, the cover described in sub-paragraph (d) above ceases to be available at commercially reasonable terms, the Contractor shall (as insuring Party) give notice to the Employer, with supporting particulars. The Employer shall then (i) be entitled subject to New-Clause 2.4/PCC [Employer's Claims] to payment of an amount equivalent to such commercially reasonable terms as the Contractor should have expected to have paid for such cover, and (ii) be deemed, unless he obtains the cover at commercially reasonable terms, to have approved the omission under Sub-Clause 13.6/PCC [General Requirements for Insurances].

13.8 Insurance against injury to Persons and Damage to Property

The insuring Party shall insure against each Party's liability for any loss, damage, death or bodily injury which may occur to any physical property (except things insured under Sub-Clause 13.7/PCC [Insurance for Works and Contractor's Equipment]) or to any person (except persons insured under Sub-Clause 13.9/PCC [Insurance for Contractor's Personnel]), which may arise out of the Contractor's performance of the Contract and occurring before the issue of the Performance Certificate.

This insurance shall be for a limit per occurrence of not less than the amount stated in the Contract Data, with no limit on the number of occurrences. If an amount is not stated in the Contract Data, this Sub-Clause shall not apply.

Unless otherwise stated in the Special Conditions of Contract, the insurances specified in this Sub-Clause:

- (a) shall be effected and maintained by the Contractor as insuring Party,
- (b) shall be in the joint names of the Parties,
- (c) shall be extended to cover liability for all loss and damage to the Employer's property including Railways Property (except things insured under Sub-Clause 13.7/PCC) arising out of the Contractor's performance of the Contract, and
- (d) may however exclude liability to the extent that it arises from:
 - (i) the Employer's right to have the Permanent Works executed on, over, under, in or through any land, and to occupy this land for the Permanent Works,
 - (ii) damage which is an unavoidable result of the Contractor's obligations to execute the Works and remedy any defects, and
 - (iii) a cause listed in Sub-Clause 11.3/PCC [Employer's Risks], except to the extent that cover is available at commercially reasonable terms.

13.9 Insurance for Contractor's Personnel

The Contractor shall abide by the provisions of ESIC Act, 1948 (extended from time to time) to take care of insurance against liability for claims, damages, losses and expenses

	<p>(including legal fees and expenses) arising from injury, sickness or disease. In addition, the contractor shall also maintain insurance against liability for claim of death of any person employed by the Contractor or any other of the Contractor's Personnel.</p> <p>The Employer and the Engineer shall also be indemnified under the policy of insurance, except that this insurance may exclude losses and claims to the extent that they arise from any act or neglect of the Employer or of the Employer's Personnel.</p> <p>The insurance shall be maintained in full force and effect during the whole time that these personnel are assisting in the execution of the Works. For a Subcontractor's employees, the insurance may be effected by the Subcontractor, but the Contractor shall be responsible for compliance with this Clause.</p> <p>Maximum number of deductibles for insurance of Employer's risks: Nil</p>
<p>Clause- 22/CC. Right of Access to the Site</p>	<p>The following para is added to the existing CC clause:</p> <p>The Employer shall give the Contractor right of access to, and possession of, all parts of the Site within the time (or times) stated in the Contract Data. The right and possession may not be exclusive to the Contractor. If, under the Contract, the Employer is required to give (to the Contractor) possession of any foundation, structure, plant or means of access, the Employer shall do so in the time and manner stated in the Specification. However, the Employer may withhold any such right or possession until the Performance Security has been received.</p> <p>If no such time is stated in the Contract Data, the Employer shall give the Contractor right of access to, and possession of, the Site within such times as may be required to enable the Contractor to proceed in accordance with the programme submitted under Sub-Clause 25.3/PCC [Programme].</p> <p>If the Contractor suffers delay as a result of a failure by the Employer to give any such right or possession within such time, the Contractor shall give notice to the Engineer and shall be entitled to:</p> <p>(a) an extension of time for any such delay, if completion is or will be delayed, under Sub-Clause 26.5/PCC [Extension of Time for Completion], and</p> <p>After receiving this notice, the Engineer shall proceed in accordance with New-Clause 3.5/PCC [Determinations] to agree or determine these matters.</p> <p>However, if and to the extent that the Employer's failure was caused by any error or delay by the Contractor, including an error in, or delay in the submission of, any of the Contractor's Documents, the Contractor shall not be entitled to such extension of time or new rates.</p> <p>Right of access to the work site will be provided to the successful Contractor. A minimum corridor of 9m will be available. The Contractor to note this while making Launching plans. The Contractor shall prepare, at his cost, approach roads to the site of work and this cost will not be reimbursed by the Employer. The Employer reserves the right to make use of these service roads for themselves or other Contractors working on the project, as and when necessary, without any payment to the Contractor. The barricading to the extent feasible subject to a maximum of 9m width (LHS+RHS) shall be permitted for carrying out the works and suitable barricading width for off-road structures in stages as per the approved sequence of construction. The employer shall grant the contractor right of access to, and/ or possession of the site progressively for the completion of works. The contractor</p>

	will draw/ modify the schedule for completion of work according to progressive possession/ right of such sites.
Clause 25 of CC	<p>The following paras are added to the Existing CC Clauses.</p> <p>25.3 Programme</p> <p>The Contractor shall submit a detailed time programme to the Engineer within 28 days after receiving the notice under Sub-Clause 26.3/PCC [Commencement of Works]. The program shall include the physical and Financial Progress vis-à-vis program and forecast cash flow adopting Project Management Software Primavera/Sure Track/MS Project or as mutually agreed. The program must identify the milestones, interface requirements and program reporting elements. The Contractor shall supply, free of cost one set of authorized software to the Engineer and the soft copy of structured program for the project. This shall be updated every month. The Contractor shall also submit a revised programme whenever the previous programme is inconsistent with actual progress or with the Contractor's obligations. Each programme shall include:</p> <ul style="list-style-type: none"> (a) the order in which the Contractor intends to carry out the Works, including the anticipated timing of each stage of design (if any), Contractor's Documents, procurement, manufacture of Plant, delivery to Site, construction, erection and testing, (b) each of these stages for work by each nominated Subcontractor (as defined in Clause 7/PCC [Nominated Subcontractors]), (c) the sequence and timing of inspections and tests specified in the Contract, and (d) a supporting report which includes: <ul style="list-style-type: none"> (i) a general description of the methods which the Contractor intends to adopt, and of the major stages, in the execution of the Works, and (ii) details showing the Contractor's reasonable estimate of the number of each class of Contractor's Personnel and of each type of Contractor's Equipment, required on the Site for each major stage. <p>Unless the Engineer, within 21 days after receiving a programme, gives notice to the Contractor stating the extent to which it does not comply with the Contract, the Contractor shall proceed in accordance with the programme, subject to his other obligations under the Contract. The Employer's Personnel shall be entitled to rely upon the programme when planning their activities.</p> <p>The Contractor shall promptly give notice to the Engineer of specific probable future events or circumstances which may adversely affect the work, increase the Contract Price or delay the execution of the Works. The Engineer may require the Contractor to submit an estimate of the anticipated effect of the future event or circumstances, and/or a proposal under Sub-Clause 34.3/PCC [Variation Procedure].</p> <p>If, at any time, the Engineer gives notice to the Contractor that a programme fails (to the extent stated) to comply with the Contract or to be consistent with actual progress and the Contractor's stated intentions, the Contractor shall submit a revised programme to the Engineer within 15 days in accordance with this Sub-Clause.</p>

<p>Clause 26 of CC</p>	<p>The following paras are added to the Existing CC Clauses.</p> <p>26.3 Commencement of Works</p> <p>The Engineer shall give the Contractor not less than 7 days' notice of the Commencement of work. Unless otherwise stated in the Special Conditions of Contract, the Commencement of work shall be within the number of days after the Contractor receives the Letter of Acceptance as specified in Contract Data.</p> <p>The Contractor shall commence the execution of the Works as soon as is reasonably practicable after the Commencement Date, and shall then proceed with the Works with due expedition and without delay.</p> <p>26.4 Time for Completion</p> <p>The Contractor shall complete the whole of the Works, and each Section (if any), within the Time for Completion for the Works or Section (as the case may be), including:</p> <ul style="list-style-type: none"> (a) achieving the passing of the Tests on Completion, and (b) completing all work which is stated in the Contract as being required for whole of the Works or Section(s) to be considered to be completed for the purposes of taking-over under Sub-Clause 46.1/PCC [Taking Over of the Works and Sections]. <p>26.5 Extension of Time for Completion</p> <p>The Contractor shall be entitled subject to Sub-Clause 4.1/SCC [Contractor's Claims] to an extension of the Time for Completion if and to the extent that completion for the purposes of Sub-Clause 46.1/PCC [Taking-Over of the Works and Sections] is or will be delayed by any of the following causes:</p> <ul style="list-style-type: none"> a) a Variation (unless an adjustment to the Time for Completion has been agreed under Sub-Clause 34.3/PCC [Variation Procedure]) or other substantial change in the quantity of an item of work included in the Contract, b) a cause of delay giving an entitlement to extension of time under a Sub-Clause of these Conditions, c) exceptionally adverse climatic conditions, d) Unforeseeable shortages in the availability of personnel or Goods caused by epidemic or governmental actions, or e) any delay, impediment or prevention caused by or attributable to the Employer, the Employer's Personnel, or the Employer's other contractors. <p>If the Contractor considers himself to be entitled to an extension of the Time for Completion, the Contractor shall give notice to the Engineer in accordance with Sub-Clause 4.1/SCC [Contractor's Claims]. When determining each extension of time under Sub-Clause 4.1/SCC the Engineer shall review previous determinations and may increase, but shall not decrease, the total extension of time.</p> <p>26.6 Delays Caused by Authorities</p> <p>If the following conditions apply, namely:</p> <ul style="list-style-type: none"> (a) the Contractor has diligently followed the procedures laid down by the relevant legally constituted public authorities in the Country,
-------------------------------	---

(b) these authorities delay or disrupt the Contractor's work, and

(c) the delay or disruption was Unforeseeable,

then this delay or disruption will be considered as a cause of delay under sub-paragraph (b) of Sub-Clause 26.5/PCC [Extension of Time for Completion].

26.7 Rate of Progress

If, at any time:

(a) actual progress is too slow to complete within the Time for Completion, and/or

(b) progress has fallen (or will fall) behind the current programme under Sub-Clause 25.3/PCC [Programme],

other than as a result of a cause listed in Sub-Clause 26.5/PCC [Extension of Time for Completion], then the Engineer may instruct the Contractor to submit, under Sub-Clause 25.3/PCC [Programme], a revised programme and supporting report describing the revised methods which the Contractor proposes to adopt in order to expedite progress and complete within the Time for Completion.

Unless the Engineer notifies otherwise, the Contractor shall adopt these revised methods, which may require increases in the working hours and/or in the numbers of Contractor's Personnel and/or Goods, at the risk and cost of the Contractor. If these revised methods cause the Employer to incur additional costs, the Contractor shall subject to New-Clause 2.4/PCC [Employer's Claims] pay these costs to the Employer, in addition to delay damages (if any) under Sub-Clause 26.8/PCC below

26.8 Extension of Time for Completion with Delay Damages

If the Contractor fails to comply with Sub-Clause 26.4/PCC [Time for Completion for entire work or for specified section wise completion period], and he is not entitled to an extension of time under sub clause 26.5/PCC then the employer may grant extension of time with delay damage in such case, the Contractor shall subject to New-Clause 2.4/PCC [Employer's Claims] pay delay damages to the Employer for this default. These delay damages shall be the sum stated in the Contract Data, which shall be paid for every day which shall elapse between the relevant Time for Completion and the date stated in the Taking-Over Certificate. However, the total amount due under this Sub-Clause shall not exceed the maximum amount of delay damages (if any) stated in the Contract Data.

Further, if the contractor fails to achieve physical/financial targets as per the agreed programme for a consecutive period of 3 months without any valid reasons, other than attributable to the contractor, a provisional recovery of delay damages shall be made from the next interim payment certificate @ 1/10th of the sum of delay damages stated in the contract data, for the entire period of 3 months. Such recovery shall continue from the further interim payment certificates till the contractor is able to make good the shortfall and achieve the cumulative targets as per agreed programme. On achieving the cumulative progress targets as per agreed programme, the entire amount recovered till that month, shall be refunded to the contractor in the next interim payment certificate. In case the contractor is unable to make good the shortfall and achieve the cumulative targets resulting in delay in completion of the project, then the provisional recoveries made shall be adjusted against the delay damages to be finally imposed on the contractor.

These delay damages shall be the only damages due from the Contractor for such default, other than in the event of termination under Sub-Clause 49.7/PCC [Termination by Employer] prior to completion of the Works. These damages shall not relieve the Contractor from his obligation to complete the Works, or from any other duties, obligations or responsibilities which he may have under the Contract.

26.9 Suspension of Work

The Engineer may at any time instruct the Contractor to suspend progress of part or all of the Works. During such suspension, the Contractor shall protect, store and secure such part or the Works against any deterioration, loss or damage.

The Engineer may also notify the cause for the suspension. If and to the extent that the cause is notified and is the responsibility of the Contractor, the following Sub-Clauses 26.10, 26.11 and 26.12 of PCC shall not apply.

26.10 Consequences of Suspension

If the Contractor suffers delay and/or incurs Cost from complying with the Engineer's instructions under Sub-Clause 26.9/PCC [Suspension of Work] and/or from resuming the work, the Contractor shall give notice to the Engineer and shall be entitled subject to Sub-Clause 4.1/SCC [Contractor's Claims] to:

- (a) an extension of time for any such delay, if completion is or will be delayed, under Sub-Clause 26.5/PCC [Extension of Time for Completion], and
- (b) payment of any such Cost, which shall be included in the Contract Price.

After receiving this notice, the Engineer shall proceed in accordance with New-Clause 3.5/PCC [Determinations] to agree or determine these matters.

The Contractor shall not be entitled to an extension of time for, or to payment of the Cost incurred in, making good the consequences of the Contractor's faulty design, workmanship or materials, or of the Contractor's failure to protect, store or secure in accordance with Sub-Clause 26.9/PCC [Suspension of Work].

If suspension is ordered by the Engineer for reasons other than those mentioned in Sub Clause 26.9/PCC then the Contractor's entitlement is in the table below. However, Engineer's decision is final and binding in regard to defining suspension and specifying the suspension period. Contractor has no right to claim or appeal against this decision

Sr. No	Suspension Period	Extension of Time	Compensation for the suspension period	Remarks
1	Up to 60 days	NO	NO	Engineer may give extension of time in exceptional circumstances
2	60-90 days	YES	NO	Extension of time as considered proper by the Engineer

3	Above 90 days	YES	<p>A. As per Daily rate of wages for idle labour/employees</p> <p>B. 70% of the rate for hire charges for idle plant and machinery (excluding cost of fuel and lubricants)</p> <p>C. 15% above all these items to cover overhead costs</p>	Compensation as assessed by the Engineer on submission of documentary proof by the Contractor to Engineer's satisfaction
---	---------------	-----	--	--

26.11 Payment for Plant and Materials in Event of Suspension

The Contractor shall be entitled to payment of the value (as at the date of suspension) of Plant and/or Materials, if:

- (a) the work on Plant or delivery of Plant and/or Materials has been suspended for more than 28 days,
- (b) the Contractor has marked the Plant and/or Materials as the Employer's property in accordance with the Engineer's instructions, and
- (c) Such materials or plant is received at site

26.12 Prolonged Suspension

If the suspension under Sub-Clause 26.9/PCC [Suspension of Work] has continued for more than 84 days, the Contractor may request the Engineer's permission to proceed. If the Engineer does not give permission within 28 days after being requested to do so, the Contractor may, by giving notice to the Engineer, treat the suspension as an omission under Clause 34/PCC [Variations and Adjustments] of the affected part of the Works. If the suspension affects the whole of the Works, the Contractor may give notice.

26.13 Resumption of Work

After the permission or instruction to proceed is given, the Contractor and the Engineer shall jointly examine the Works and the Plant and Materials affected by the suspension. The Contractor shall make good any deterioration or defect in or loss of the Works or Plant or Materials, which has occurred during the suspension

26.14 Bonus for early completion:

In the event that the Project Completion Date occurs prior to the Scheduled Completion Date, the Contractor shall be entitled to receive a payment of bonus equivalent to 1% (one per cent) of the Contract Price for per month (part of the month to be excluded) by which the Project Completion Date precedes the Scheduled Completion Date, but subject to a maximum of 3% (three per cent) of the Contract Price. Provided, however, that the payment of bonus, if any, shall be made only after the issue of the Completion Certificate. For the

avoidance of doubt, the Parties agree that for the purpose of determining the bonus payable hereunder, the Contract Price shall always be deemed to be the amount and shall exclude any revision thereof for any reason.

If the Contractor achieves completion of the whole of the Works or any section(s) prior to the intended Completion Date prescribed in Contract data (Extension of time pursuant to Clause 26.5/PCC or any other clause of these conditions will not be considered), the Employer shall pay to the Contractor a sum stated in the Contract data as bonus for early completion, for every calendar month which shall elapse between the date of completion of all items of works as stipulated in the contract, including variations ordered by the Engineer and the time prescribed in Clause 26.4.

For the purpose of calculating bonus payments, the time given in the Bid for completion of the whole works or any section(s) is fixed and unless otherwise agreed, no adjustment of the time by reasons of granting an extension of time pursuant to clause 26.5/PCC or any other clause of these conditions will be allowed. Any period falling short of completed month shall be ignored for the purpose of computing the period relevant for the payment of bonus.

Amount of bonus for early completion

1% of initial Contract Price per month (part of the month to be excluded) for substantial completion of work.

Maximum limit of bonus

3% of Contract Price.

(For earlier completion of the work as a whole from the stipulated original date of completion, a bonus payment of as above shall be paid to the contractor. The engineer's decision is final and binding on the contractor so far as bonus payment to the contractor is concerned. If bonus payment is made, earlier penalties levied for delay caused to various intermediate Key Dates will be refunded.)

26.15 Suspension of unsafe Construction Works

1. Upon recommendation of the Authority's Engineer to this effect, or on its own volition in cases of emergency or urgency, the Authority may by notice require the Contractor to suspend forthwith the whole or any part of the Works if, in the reasonable opinion of the Authority's Engineer or the Authority, as the case may be, such work threatens the safety of the Users and or other persons on or about the Railway Project.
2. The Contractor shall, pursuant to the notice under the above clause, suspend the Works or any part thereof for such time and in such manner as may be specified by the Authority and thereupon carry out remedial measures to secure the safety of suspended works, the Users, other persons and vehicles on or about the Railway Project including pedestrians. The Contractor may by notice require the Authority's Engineer to inspect such remedial measures forthwith and make a report to the Authority recommending whether or not the suspension hereunder may be revoked. Upon receiving the recommendations of the Authority's Engineer, the Authority shall either revoke such suspension or instruct the Contractor to carry out such other and further remedial measures as may be necessary in the reasonable opinion of the Authority, and the procedure set forth in this Clause shall be repeated until the suspension hereunder is revoked.

	<p>3. Subject to the provisions of the contract, all reasonable costs incurred for maintaining and protecting the Works or part thereof during the period of suspension (the "Preservation Costs"), shall be borne by the Contractor.</p> <p>4. If suspension of Works is for reasons not attributable to the Contractor, the Authority's Engineer shall determine any Time Extension to which the Contractor is reasonably entitled.</p>
<p>Clause-30/CC</p>	<p>The following paras are added to the Existing CC Clauses.</p> <p>30.2 Contractor's Obligations</p> <p>The Contractor shall carry out the Tests on Completion in accordance with this Clause and New-Clause 5.4/PCC [Testing], after providing the documents in accordance with sub-paragraph (d) of New--Clause 4.1/PCC [Contractor's General Obligations].</p> <p>The Contractor shall give to the Engineer not less than 21 days' notice of the date after which the Contractor will be ready to carry out each of the Tests on Completion. Unless otherwise agreed, Tests on Completion shall be carried out within 14 days after this date, on such day or days as the Engineer shall instruct.</p> <p>In considering the results of the Tests on Completion, the Engineer shall make allowances for the effect of any use of the Works by the Employer on the performance or other characteristics of the Works. As soon as the Works, or a Section, have passed any Tests on Completion, the Contractor shall submit a certified report of the results of these Tests to the Engineer.</p> <p><u>Contractor's Obligations:</u> The Contractor shall carry out the Tests on Completion at his own cost in accordance with the Contract and shall provide the documents in accordance with New-Clauses 3.1/PCC and the Contractor shall give, to the Engineer, 21days' notice of the date after which the Contractor will be ready to carry out the Tests on Completion. Unless otherwise agreed, such Tests shall be carried out within 14 days after this date, on such day or days as the Engineer shall instruct.</p> <p>Unless otherwise stated in Conditions of Contract/SCC, the Tests on Completion shall be carried out in the following sequence</p> <ol style="list-style-type: none"> (a) pre-commissioning test, which shall include appropriate instructions and ("dry" or "cold") functional tests to demonstrate that each item of the Plant and Work can safely undertake the next stage (b) Commissioning Test shall include the specified operational tests to demonstrate Works or Sections can be operated safely and as specified under all available operating condition (c) trial operation which shall demonstrate that the Works or Section perform reliably and in accordance with the Contract <p>The Contractor at his own cost shall arrange all tools, equipment, gadgets, facilities or as deemed necessary by the Engineer for such tests, in considering the results of the Tests on Completion, the Engineer shall make allowances for the effect of any use of the Works by the Employer on the performance or other characteristics of the Works. As soon as the Works, or a Section, have passed the Tests on Completion described in sub-paragraphs (a) (b) or (c),the Contractor shall provide the Engineer and the Employer with a certified report of the results of all such Tests</p>

30.3 Delayed Tests

If the Tests on Completion are being unduly delayed by the Employer, New-Clause 5.4/PCC [Testing] (fifth paragraph) and/or Sub-Clause 46.3/PCC [Interference with Tests on Completion] shall be applicable.

If the Tests on Completion are being unduly delayed by the Contractor, the Engineer may by notice require the Contractor to carry out the Tests within 21 days after receiving the notice. The Contractor shall carry out the Tests on such day or days within that period as the Contractor may fix and of which he shall give notice to the Engineer.

If the Contractor fails to carry out the Tests on Completion within the period of 21 days, the Employer's Personnel may proceed with the Tests at the risk and cost of the Contractor. The Tests on Completion shall then be deemed to have been carried out in the presence of the Contractor and the results of the Tests shall be accepted as accurate.

30.4 Retesting

If the Works, or a Section, fail to pass the Tests on Completion, New-Clause 5.5/PCC [Rejection] shall apply, and the Engineer or the Contractor may require the failed Tests, and Tests on Completion on any related work, to be repeated under the same terms and conditions

30.5 Failure to Pass Tests on Completion

If the Works, or a Section, fail to pass the Tests on Completion repeated under Sub-Clause 30.4/PCC [Retesting], the Engineer shall be entitled to:

- (a) order further repetition of Tests on Completion under Sub-Clause 30.4;
- (b) if the failure deprives the Employer of substantially the whole benefit of the Works or Section, reject the Works or Section (as the case may be), in which event the Employer shall have the same remedies as are provided in sub-paragraph (c) of New-Clause 6.4/PCC [Failure to Remedy Defects]; or
- (c) issue a Taking-Over Certificate, if the Employer so requests.

In the event of sub-paragraph (c), the Contractor shall proceed in accordance with all other obligations under the Contract, and the Contract Price shall be reduced by such amount as shall be appropriate to cover the reduced value to the Employer as a result of this failure. Unless the relevant reduction for this failure is stated (or its method of calculation is defined) in the Contract, the Employer may require the reduction to be (i) agreed by both Parties (in full satisfaction of this failure only) and paid before this Taking-Over Certificate is issued, or (ii) determined and paid under New-Clause 2.4 [Employer's Claims] and New-Clause 3.5 [Determinations].

30.6 Contractor's obligations

Notwithstanding the provisions of New-clauses 4.1/PCC, clause 30.2 to 30.5/PCC the provisions in subsequent sub-clauses shall apply for works of Permanent Way, signaling and telecommunication and railway electrification excluding General Electrical Services.

- (a) The Contractor shall be responsible for the execution of temporary and/or permanent works which may require the prior sanction/approval of Commissioner of Railway Safety (CRS) in accordance with extant rules for "The Railways opening for Public Carriage of Passengers" was amended from time to time. And applicable as and when the works are undertaken. The Contractor shall initiate the process for approval at least **63** (sixty-

	<p>three) days prior to undertaking such works which require the approval of Commissioner of Railway Safety (CRS) and furnish draft documentation to the Engineer.</p> <p>(b) The Contractor shall ensure that existing services and operations for public carriage of passengers or goods, are not affected except those, which are essentially required to be regulated for execution of works. Such items of works shall be planned and coordinated through the Engineer.</p> <p>(i) Prior to the commencement of commercial operations of passenger traffic, the Employer may permit freight train operations to Railway after certification by the authorized person of Zonal Railway. The Contractor shall be responsible for maintaining the facilities ensuring safety of operations as per specifications.</p>
<p>Clause 34/CC</p>	<p>The following paras are replaced to the Existing CC Clause 34.</p> <p>VARIATIONS AND ADJUSTMENTS.</p> <p>34.1 Right to Vary</p> <p>Variations may be initiated by the Employer at any time prior to issuing the Taking-Over Certificate for the Works, either by an instruction or by making a request to the Contractor to submit a proposal.</p> <p>The Contractor shall execute and be bound by each variation till the price does not exceed 25% of the agreement value as specified in LOA/Original agreement. For variation beyond the above the contractor shall be bound to execute, unless the Contractor promptly gives notice to the Engineer stating (with supporting particulars) that the Contractor cannot readily obtain the Goods required for the Variation. Upon receiving this notice, the Engineer shall cancel, confirm or vary the instruction.</p> <p>Each Variation may include:</p> <ul style="list-style-type: none"> (a) changes to the quantities of any item of work included in the Contract, (b) changes to the quality and other characteristics of any item of work, (c) changes to the levels, positions and/or dimensions of any part of the Works, (d) omission of any work unless it is to be carried out by others, (e) any additional work, Plant, Materials or services necessary for the Permanent Works, including any associated Tests on Completion, boreholes and other testing and exploratory work, or (f) changes to the sequence or timing of the execution of the Works. <p>The Contractor shall not make any alteration and/or modification of the Permanent Works, unless and until the Engineer instructs or approves a Variation</p> <p>34.2 Value Engineering</p> <p>The Contractor may, at any time, submit to the Engineer a written proposal which (in the Contractor's opinion) will, if adopted, (i) accelerate completion, (ii) reduce the cost to the Employer of executing, maintaining or operating the Works, (iii) improve the efficiency or value to the Employer of the completed Works, or (iv) otherwise be of benefit to the Employer.</p>

The proposal shall be prepared at the cost of the Contractor and shall include the items listed in Sub-Clause 34.3/PCC [Variation Procedure].

If a proposal, which is approved by the Engineer, includes a change in the design of part of the Permanent Works, then unless otherwise agreed by both Parties:

- (a) the Contractor shall design this part,
- (b) sub-paragraphs (a) to (d) of New-Clause 4.1/PCC [Contractor's General Obligations] shall apply, and
- (c) if this change results in a reduction in the contract value of this part, the Engineer shall proceed in accordance with New-Clause 3.5/PCC [Determinations] to agree or determine a fee, which shall be included in the Contract Price. This fee shall be half (50%) of the difference between the following amounts:
 - (i) such reduction in contract value, resulting from the change, excluding adjustments under Sub-Clause 34.7/PCC [Adjustments for Changes in Legislation] and Sub-Clause PVC/Contract Data [Adjustments for Changes in Cost], and
 - (ii) the reduction (if any) in the value to the Employer of the varied works, taking account of any reductions in quality, anticipated life or operational efficiencies.

However, if amount (i) is less than amount (ii), there shall not be a fee.

34.3 Variation Procedure

If the Engineer requests a proposal, prior to instructing a Variation, the Contractor shall respond in writing as soon as practicable, either by giving reasons why he cannot comply (if this is the case) or by submitting:

- (a) a description of the proposed work to be performed and a programme for its execution,
- (b) the Contractor's proposal for any necessary modifications to the programme according to Sub-Clause 25.3/PCC [Programme] and to the Time for Completion, and
- (c) the evaluation of the Variation shall be as specified in New-Clause 35/PCC [Payment for Variation].

The Engineer shall, as soon as practicable after receiving such proposal (under Sub-Clause 34.2/PCC [Value Engineering] or otherwise), respond with approval, disapproval or comments. The Contractor shall not delay any work whilst awaiting a response.

Each instruction to execute a Variation, with any requirements for the recording of Costs, shall be issued by the Engineer to the Contractor, who shall acknowledge receipt.

Each Variation shall be evaluated in accordance with New-Clause 7 [Measurement and Evaluation], unless the Engineer instructs or approves otherwise in accordance with this Clause.

34.4 Payment in Applicable Currencies

If the Contract provides for payment of the Contract Price in more than one currency, then whenever an adjustment is agreed, approved or determined as stated above, the amount payable in each of the applicable currencies shall be specified. For this purpose, reference shall be made to the actual or expected currency proportions of the Cost of the varied work, and to the proportions of various currencies specified for payment of the Contract Price.

34.5 Provisional Sums

Each Provisional Sum shall only be used, in whole or in part, in accordance with the Engineer's instructions, and the Contract Price shall be adjusted accordingly. The total sum paid to the Contractor shall include only such amounts, for the work, supplies or services to which the Provisional Sum relates, as the Engineer shall have instructed. For each Provisional Sum, the Engineer may instruct:

- (a) work to be executed (including Plant, Materials or services to be supplied) by the Contractor and valued under Sub-Clause 34.3/PCC [Variation Procedure]; and/or
- (b) Plant, Materials or services to be purchased by the Contractor, from a nominated Subcontractor (as defined in Clause 7 [Nominated Subcontractors]) or otherwise; and for which these shall be included in the Contract Price:
 - (i) the actual amounts paid (or due to be paid) by the Contractor, and
 - (ii) a sum for overhead charges and profit, calculated as a percentage of these actual amounts by applying the relevant percentage rate (if any) stated in the appropriate Schedule. If there is no such rate, the percentage rate stated in the Contract Data shall be applied.

The Contractor shall, when required by the Engineer, produce quotations, invoices, vouchers and accounts or receipts in substantiation

34.6 Day work

For work of a minor or incidental nature, the Engineer may instruct that a Variation shall be executed on a daywork basis. The work shall then be valued in accordance with the Daywork Schedule included in the Contract, and the following procedure shall apply. If a Daywork Schedule is not included in the Contract, this Sub-Clause shall not apply.

Before ordering Goods for the work, the Contractor shall submit quotations to the Engineer. When applying for payment, the Contractor shall submit invoices, vouchers and accounts or receipts for any Goods.

Except for any items for which the Daywork Schedule specifies that payment is not due, the Contractor shall deliver each day to the Engineer accurate statements in duplicate which shall include the following details of the resources used in executing the previous day's work:

- (a) the names, occupations and time of Contractor's Personnel,
- (b) the identification, type and time of Contractor's Equipment and Temporary Works, and
- (c) the quantities and types of Plant and Materials used.

One copy of each statement will, if correct, or when agreed, be signed by the Engineer and returned to the Contractor. The Contractor shall then submit priced statements of these resources to the Engineer, prior to their inclusion in the next Statement under Sub-Clause 37.1/PCC [Application for Interim Payment Certificates]

34.7 Adjustments for Changes in Legislation

Contract Price shall be adjusted to take account of any increase or decrease in Cost resulting from a change in the Laws of the Country (including the introduction of new Laws and the repeal or modification of existing Laws) or in the judicial or official governmental interpretation of such Laws, made after the Base Date, which affect the Contractor in the performance of obligations under the Contract.

	<p>If the Contractor suffers (or will suffer) delay and/or incurs (or will incur) additional Cost as a result of these changes in the Laws or in such interpretations, made after the Base Date, the Contractor shall give notice to the Engineer and shall be entitled subject to Sub-Clause 4.1/SCC [Contractor's Claims] to:</p> <p>(a) an extension of time for any such delay, if completion is or will be delayed, under Sub-Clause 26.5/PCC [Extension of Time for Completion], and</p> <p>(b) payment of any such Cost, which shall be included in the Contract Price.</p> <p>After receiving this notice, the Engineer shall proceed in accordance with New-Clause 3.5 [Determinations] to agree or determine these matters.</p> <p>In case there is a decrease in cost as a result of changes of Law by Legislation after the Base Date, the Engineer shall proceed in accordance with New-Clause 3.5 (determination) to agree or determine these matters without waiting for Contractor's / Employer's Notice.</p> <p>Notwithstanding the foregoing, the Contractor shall not be entitled to such an extension of time if the same shall already have been taken into account in determining an extension and such Cost shall not be separately paid if the same shall already have been taken into account in the indexing of any inputs to the table of adjustment data in accordance with the provisions of Sub-Clause PVC/Contract Data.</p> <p>34.8 VITIATION CLAUSE: DELETED</p>
<p>Clause 35/CC</p>	<p>The clause 35 of CC is substituted with following paras.</p> <p>1. Variations/ new items:</p> <p>1.1 The Employer shall have the power to order the Contractor to do any or all of the following as considered necessary or advisable during the progress of the work by him.</p> <ol style="list-style-type: none"> a. increase or decrease of any item of work included in the Bill of Quantities (BOQ) b. Omit any item of work c. Change the character or quality or kind of any item of work d. Change the levels, lines, positions, and dimensions of any part of the work; e. Execute additional items of work of any kind necessary for the completion of the works f. Change in any specified sequence, method, or timing of construction of any part of the work. <p>1.2 The Contractor shall be bound to carry out the work in accordance with any instructions in this connection, which may be given to him in writing by the Employer and such alteration shall not vitiate or invalidate the Contract.</p> <p>1.3 Variations shall not be made by the Contractor without an order in writing by the Employer, provided that no order in writing shall be required for an increase or decrease in the quantity of an item appearing in the BOQ so long as the work executed conforms to the approved drawings.</p> <p>1.4 The Contractor shall not make any alteration and/or modification of the Works, unless and until the Engineer instructs or gives consent to a Variation.</p> <p>1.5 If the Construction and/or Manufacture Documents or Works are not in accordance with the Contract, the rectification shall not constitute a Variation.</p>

2. Payments for Variations/new items

- 2.1 Payment for the increase in the quantities of an item in the BOQ up to 25% of that provided in the Bill of Quantities shall be made at the rates quoted by the Contractor.
- 2.2 For quantities in excess of 125% of the tendered quantity of an item as given in the BOQ, the Contractor shall be paid at the reasonable rate derived from the details mentioned in para no. 5 (applicable for the area of work and current at the time of variations), plus-minus the overall percentage of the original tendered rates over the current schedule of rates prevalent at the time of contract.
- 2.3 If there is no rate for the additional, substituted, or altered item of the work in the BOQ, efforts would be made to derive the rates from those given in the BOQ or the Schedule of Rates (applicable for the area of the work and current at the time of award of Contract) and if found feasible the payment would be made at the derived rate for the item plus or minus the overall percentage of the original tendered rates over the current Schedule of Rates prevalent at the time of award of Contract.
- 2.4 If the rates for additional, substituted, or altered items of work cannot be determined either as at 2.1, 2.2, or 2.3 above, the Contractor shall be requested to submit his quotation for the items supported by analysis of the rate or rates claimed, within 7 days.
- 2.5 If the Contractor's quotation is determined unreasonable, the Employer may order the Variation and make a change to the Contract Price which shall be based on the Employer's own forecast of the effects of the Variation on the Contractor's costs.
- 2.6 Under no circumstances the Contractor shall suspend the work on the plea of non-settlement of rates for items falling under this Clause.

3. Procedure for the operation of new items/ variations

The following procedure is to be followed in dealing with the proposal for variation in contractual quantity and/or new items

- 3.1 If any item of work that is not provided for in the BOQ or in case of variation in BOQ Quantity is to be operated, the contractor shall take the instructions in writing from the Engineer as per the relevant Clause specified in the conditions of the contract on Variations.
- 3.2 The contractor on receipt of the instructions shall submit a proposal with the details as specified in the Contract including the proposed rates for the items and proper analysis for the same. (New items and Beyond 125% of individual items in case of variation)
- 3.3 The Engineer on receipt of the claim from the contractor for new items and/or variation in BOQ quantity, shall scrutinize the same and determine the rates strictly based on the specific contract conditions and submit the same with his recommendations to the concerned HOD who shall forward the same to the

	<p>standing committee for further scrutiny. (New items and Beyond 125% of individual items in case of variation)</p> <p>3.4 The nominated committee shall examine the proposal and submit its recommendations for the approval of the Competent Authority</p> <p>4. Rate for variation and new items</p> <p>General principle to be adopted shall be, in case of relevant LAR is available it should be considered. In the absence of relevant LAR, SOR rates/ analysis mentioned as per SOR to be followed.</p> <p>In case of General Electrical works and utility shifting works policy letter issued from time to time by government of Karnataka shall be followed. For Traction related works policy mentioned in para 3 above shall be followed.</p> <p>The rate for new items or variations beyond 125% may be derived from the latest reasonable rates of following sequence: KRIDE LAR SWR LAR BMRCL LAR SOR of KPWD/KPTCL USSOR Railways SOR of CPWD</p> <p>In the absence/conflict of above (LAR/ SOR) rate may be derived as below.</p> <ol style="list-style-type: none"> a. Cost of Materials at current market price, as may be actually utilized in the final finished Permanent Works, including a reasonable percentage for wastage and transportation. b. Cost of enabling works, if any, (unless provided for separately) worked out on the above basis but with less stringent quality. Specifications minus the salvage value of serviceable material released after completion of work and cost of material released as scrap. c. Cost of labor actually used at the site of work at rates under Payment of Minimum Wages Act for the area of work for each category of workers, further enhanced by a percentage of 10o/o of the aforesaid rates to account for labor not directly utilized at the Site and other ancillary and incidental expenses on labor. d. Hire charges for Plant and Machinery, scaffolding, shuttering, forms, etc. required to be used at the site of the work. The tools used by the various trades shall not be counted as Plant & Machinery for this purpose. e. An amount of 10% of items a, b, c & d above to allow for the Contractor's overheads and profit. This percentage shall also apply to the estimated cost of Materials supplied free to the contractor. f. All taxes as applicable on above.

<p>Clause 37/CC</p>	<p>The clause 37 of CC is replaced with the following.</p> <p>Payments.</p> <p>37.1 Application for Interim Payment Certificates</p> <p>Payments shall be adjusted for deductions for advance payments other than recoveries in terms of contract and taxes, at source as applicable under law. The Contractor shall be liable to pay liquidated damages for shortfall in progress. Items of the Works for which no rate or price has been entered in will not be paid for by the Employer and shall be deemed covered by other rates and prices in the Contract.</p> <p>The Contractor shall submit a Statement in six copies to the Engineer in accordance with the payment procedure specified by the Engineer, after the end of each month, in a form approved by the Engineer, showing in detail the amounts to which the Contractor considers himself to be entitled, together with supporting documents which shall include the report on the progress during this month in accordance with New-Clause 4.39/PCC [Progress Reports] and Record Measurement Sheets.</p> <p>The Statement shall include the following items, as applicable, which shall be expressed in the various currencies in which the Contract Price is payable, in the sequence listed:</p> <ul style="list-style-type: none"> (a) the estimated contract value of the Works executed and the Contractor's Documents produced up to the end of the month (including Variations but excluding items described in sub-paragraphs (b) to (g) below); (b) any amounts to be added and deducted for changes in legislation and changes in cost, in accordance with Sub-Clause 34.7/PCC [Adjustments for Changes in Legislation] and Sub-Clause PVC/Contract Data [Adjustments for Changes in Cost]; (c) any amount to be deducted for retention, calculated by applying the percentage of retention stated in the Contract Data to the total of the above amounts, until the amount so retained by the Employer reaches the limit of Retention Money (if any) stated in the Contract Data; (d) Any amounts to be added and deducted for the advance payments and repayments in accordance with sub clause 42.0/PCC [Advance Payment]; (e) any amounts to be added and deducted for Materials in accordance with New-Clause 13/PCC [Materials intended for the Works]; (f) any other additions or deductions which may have become due under the Contract or otherwise, including those under Clause 4.1/SCC [Claims, Disputes and Arbitration]; and (g) the deduction of amounts certified in all previous Payment Certificates. (h) for invoicing as per GST Laws, the estimated contract value of the Works executed in terms of (a) above and any amounts added or deducted as per (b), (e) to (g) above is to be broken up in two components i.e. (i) the base amount excluding GST (ii) GST component (calculated at the rate for works contract service as per GST Laws). (i) Statement of interim payments certificates should be submitted by the Contractor to the Engineer by the 7th day of each month for the work executed upto the end of the previous month. (j) An amount to be deducted for the payments to be made to different Departments towards payments liable to be made by the Contractor
----------------------------	---

37.2 Schedule of Payments

If the Contract includes a schedule of payments specifying the installments in which the Contract Price will be paid, then unless otherwise stated in this schedule:

- (a) the installments quoted in this schedule of payments shall be the estimated contract values for the purposes of sub-paragraph (a) of Sub-Clause 37.1/PCC [Application for Interim Payment Certificates];
- (b) New-Clause 13/PCC [Provisional payment against material at site] shall not apply; and
- (c) if these installments are not defined by reference to the actual progress achieved in executing the Works, and if actual progress is found to be less than that on which this schedule of payments was based, then the Engineer may proceed in accordance with New-Clause 3.5/PCC [Determinations] to agree or determine revised installments, which shall take account of the extent to which progress is less than that on which the installments were previously based.

If the Contract does not include a schedule of payments, the Contractor shall submit non-binding estimates of the payments which he expects to become due during each quarterly period. The first estimate shall be submitted within 42 days after the Commencement Date. Revised estimates shall be submitted at quarterly intervals, until the Taking-Over Certificate has been issued for the Works.

37.3 Issue of Interim Payment Certificates

No amount will be certified or paid until the employer has received and approved the performance security. Thereafter, the Engineer shall within two days after receiving a statement and supporting documents (including Contractor's certificate in terms of Sub-Clause 1.22/SCC, issue to the Employer a provisional interim payment certificate which shall state the amount which the Engineer determines to be due after preliminary check as per K-RIDE's procedure order. After this the Engineer shall, within 28 days after receiving a statement and supporting documents, issue to the employer an Interim Payment Certificate which shall state the amount which the Engineer fairly determines to be due, with supporting particulars.

However, prior to issuing the Taking-Over Certificate for the Works, the Engineer shall not be bound to issue the Interim Payment Certificate in an amount which would (after retention and other deductions) be less than the minimum amount of Interim Payment Certificates (if any) stated in the Contract Data. In this event, the Engineer shall give notice to the Contractor accordingly.

An Interim Payment Certificate shall not be withheld for any other reason, although:

- (a) if anything supplied or work done by the Contractor is not in accordance with the Contract, the cost of rectification or replacement may be withheld until rectification or replacement has been completed; and/or
- (b) if the Contractor was or is failing to perform any work or obligation in accordance with the Contract, and had been so notified by the Engineer, the value of this work or obligation may be withheld until the work or obligation has been performed.

The Engineer may in any Payment Certificate make any correction or modification that should properly be made to any previous Payment Certificate. A Payment Certificate shall not be deemed to indicate the Engineer's acceptance, approval, consent or satisfaction.

37.4 Payment

The Employer shall pay to the Contractor:

- (a) the first installment of the advance payment within 42 days after issuing the Letter of Acceptance or within 21 days after receiving the documents in accordance with New-Clause 4.19/PCC [Performance Security] and Sub-Clause 42.0/PCC [Advance Payment], whichever is later;
- (b) (i) After preliminary scrutiny and certifications by the Engineer, payment of 80% of the certified net payment due (after recoveries and deductions), shall be made by the Employer within 10 days of receiving a statement and supporting documents by the Engineer subject to the condition that last interim payment certificate has been settled after detailed check. In the event of the contractor submitting bills based on false measurements, Project Director should issue a written warning to him to the effect that the facility of 80% payment without detailed check will be withdrawn in future. If the contractor repeats the misconduct this facility should be withdrawn.
- (ii) The amount certified in each Interim Payment Certificate within 56 days after the Engineer receives the Statement and supporting documents. Any discrepancy shall be rectified in the next payment to the Contractor; and
- (c) the amount certified in the Final Payment Certificate within 56 days after the Employer receives this Payment Certificate or, the undisputed amount shown in the Final Statement, within 56 days after the date of notification of the suspension.

Payment of the amount due, unless specified in the Contract Data, shall be made in INR into the bank account, nominated by the Contractor.

However, in case of JV, direct payment to individual JV partners shall be made on joint certification (about the net amounts payable to individual partners) by the authorized representative of the JV and concerned respective authorized representative of individual JV partners, after making requisite recoveries/deductions from the gross payment. In case of any dispute regarding the net amounts payable to individual partners, the Engineer shall decide the same on the basis of the execution of items of works under Schedules/Bills indicated in the JV agreement as the responsibility of execution of each JV partner. Payment to individual JV partners shall be treated as payment made to the JV. The said payment shall not alter any obligation of the JV and its individual Partners under the Agreement and their obligations under the agreement shall remain joint and several.

A foreign company (either single entity or JV partner), shall have to submit proof of having opened their project office in India before any payment (including advance payment) is released to such a company. The required proof here shall be a copy of the report containing information as per format prescribed by Reserve Bank of India submitted to the Director General of Police (DGP) of the state concerned in which project office has been established.

37.5 DELETED**37.6 Delayed Payment**

If the Contractor does not receive payment in accordance with Sub-Clause 37.4/PCC [Payment], the Contractor shall be entitled to receive interest compounded monthly on the amount unpaid during the period of delay. This period shall be deemed to commence on

the date for payment specified in Sub-Clause 37.4/PCC [Payment], irrespective (in the case of its sub-paragraph (b)) of the date on which any Interim Payment Certificate is issued.

Unless otherwise stated in the Special Conditions of Contract, the interest amount be calculated at the annual rate of 7% (seven percent).

The Contractor shall be entitled to this payment without formal notice or certification, and without prejudice to any other right or remedy, if the Contractor submits the complied (Fulfilled) documents.

37.7 DELETED

37.8 DELETED

37.9 DELETED

37.10 DELETED

37.11 Statement at Completion

Within 84 days after receiving the Taking-Over Certificate for the Works, the Contractor shall submit to the Engineer six copies of a Statement at completion with supporting documents, in accordance with Sub-Clause 37.7/PCC [Application for Interim Payment Certificates], showing:

- (a) the value of all work done in accordance with the Contract up to the date stated in the Taking- Over Certificate for the Works,
- (b) any further sums which the Contractor considers to be due, and
- (c) an estimate of any other amounts which the Contractor considers will become due to him under the Contract. Estimated amounts shall be shown separately in this Statement at completion.

The Engineer shall then certify in accordance with Sub-Clause 37.3/PCC [Issue of Interim Payment Certificates].

Within 56 days after receiving the Performance Certificate, the Contractor shall submit, to the Engineer, six copies of a draft final statement as per procedure prescribed by the Engineer, with supporting documents showing in detail in a form approved by the Engineer:

37.12 Application for Final Payment Certificate

Within 56 days after receiving the Performance Certificate, the Contractor shall submit, to the Engineer, six copies of a draft final statement as per procedure prescribed by the Engineer, with supporting documents (including Contractor's certificate in terms of Sub-Clause 1.22/SCC showing in detail in a form approved by the Engineer:

- (a) the value of all work done in accordance with the Contract, and
- (b) any further sums which the Contractor considers to be due to him under the Contract or otherwise.

If the Engineer disagrees with or cannot verify any part of the draft final statement, as per procedure prescribed by the Engineer the Contractor shall submit such further information as the Engineer may reasonably require and shall make such changes in the draft as may be agreed between them. The Contractor shall then prepare and submit to the Engineer

the final statement as agreed. This agreed statement is referred to in these Conditions as the "Final Statement".

However, if, following discussions between the Engineer and the Contractor and any changes to the draft final statement which are agreed, it becomes evident that a dispute exists, the Engineer shall deliver to the Employer (with a copy to the Contractor) an Interim Payment Certificate for the agreed parts of the draft final statement. Thereafter, if the dispute is finally resolved under Sub-Clause 4.SCC [Obtaining Dispute Board's Decision] or Sub-Clause 4.2/SCC [Amicable Settlement], the Contractor shall then prepare and submit to the Employer (with a copy to the Engineer) a Final Statement.

37.13 Discharge

When submitting the Final Statement, the Contractor shall submit a discharge which confirms that the total of the Final Statement represents full and final settlement of all moneys due to the Contractor under or in connection with the Contract. This discharge may state that it becomes effective when the Contractor has received the Performance Security and the outstanding balance of this total, in which event the discharge shall be effective on such date

37.14 Issue of Final Payment Certificate

Within 28 days after receiving the Final Statement and discharge in accordance with Sub-Clause 37.12/PCC [Application for Final Payment Certificate] and Sub-Clause 37.13/PCC [Discharge], the Engineer shall issue, to the Employer, the Final Payment Certificate which shall state:

- (a) the amount which he fairly determines is finally due, and
- (b) after giving credit to the Employer for all amounts previously paid by the Employer and for all sums to which the Employer is entitled, the balance (if any) due from the Employer to the Contractor or from the Contractor to the Employer, as the case may be.

If the Contractor has not applied for a Final Payment Certificate in accordance with Sub-Clause 37.12/PCC [Application for Final Payment Certificate] and Sub-Clause 37.13/PCC [Discharge], the Engineer shall request the Contractor to do so. If the Contractor fails to submit an application within a period of 28 days, the Engineer shall issue the Final Payment Certificate for such amount as he fairly determines to be due.

37.15 Cessation of Employer's Liability

The Employer shall not be liable to the Contractor for any matter or thing under or in connection with the Contract or execution of the Works, except to the extent that the Contractor shall have included an amount expressly for it:

- (a) in the Final Statement and also
- (b) (except for matters or things arising after the issue of the Taking-Over Certificate for the Works) in the Statement at completion described in Sub-Clause 37.11/PCC [Statement at Completion].

However, this Sub-Clause shall not limit the Employer's liability under his indemnification obligations, or the Employer's liability in any case of fraud, deliberate default or reckless misconduct by the Employer

37.16 Currencies of Payment

- a) The Contract Price shall be paid in Indian Rupees (INR).

37.17 Tax Deduction at Source: Tax deductions will be made at source as per statutory requirement from every payment made to the Contractor at rates notified from time to time.

- i. **Income tax deduction:** Income Tax deduction shall be as per law.
- ii. **Labour Cess & Royalties:** The labour Cess & Royalties will be deducted as per norms of applicable law from each IPCs and remitted to the respective Authorities

37.18 Production of Vouchers

- a. The Contractor shall, whenever required by the Engineer, produce or cause to be produced for examination by the Engineer, any quotation, invoice, cost or other account books, vouchers, receipts, letters, memoranda or any copy of or extract from any such documents and also furnish information and returns, as may be required, relating to the execution of this Contract or relevant for verifying or ascertaining the cost of execution of this Contract or ascertaining the Materials supplied by the Contractor are in accordance with the Specifications laid down in the Contract. The Engineer's decision on the question of relevancy of any documents, information or returns shall be final and binding on the parties
- b. If any part or item of the Work is allowed to be carried out by a Sub-Contractor, assignee or any subsidiary or allied firm, the Engineer shall have power to secure the books of such Sub-Contractor, assignee or any subsidiary or allied firm through the Contractor, and shall have power to examine and inspect the same. The above obligations are without prejudice to the obligations of the Contractor under any statute, rules or orders.

37.19 Withholding and Lien For Sums Claimed

- (i) The Employer shall have lien on and over all materials of every description, tools, tackles, plant, equipment or any amount due and/or that may become due and payable to the Contractor under the Contract, and / or on and over the deposit of Performance Security or other amount or amounts made under the Contract and which may become payable to the Contractor. Employer may exercise a general lien also.
- (ii) And further, unless the Contractor pays and clears immediately on demand any claim of the Employer, the Employer shall at all times be entitled to deduct the amount of the said claim from the amount, securities and / or deposits which may have become or will become payable to the Contractor under the existing contract, or under any other Contract or transaction whatsoever between the Employer and the Contractor even if the matter stands referred to Arbitration. The Contractor shall have no claim for any interest or damage whatsoever in respect of any amounts withheld or treated as withheld under the lien referred to above and duly notified as such to the Contractor

37.20 Signature on Receipts for Payments

Every receipt of payment to Contractor including refund of the Performance Security shall be signed by the person authorized to do so on his behalf. In the event of death of any of the Contractor's partners in case the Contractor is a partnership firm, during the currency of the Contract, it is hereby expressly agreed that every receipt by any one of surviving Contractor's partners, shall, if so signed as aforesaid, be a good and sufficient discharge as aforesaid, provided that nothing in this Clause shall be deemed to prejudice or affect

any claim, which the Employer may hereafter have against the legal representatives of any Contractor's partner so dying, for or in respect of breach of any of the conditions of the Contract. Provided also that nothing contained in this clause shall be deemed to prejudice or affect the respective rights and obligations of the Contractor's partners, or of the legal heirs / representatives of any deceased Contractor / partner interest

37.21 Post Payment Audit

It is an agreed term of the Contract, that the Employer reserves to himself the right to carry out a post payment audit and / or technical examination of the Works, and the Final bill including all supporting vouchers, abstracts, etc., and to make a claim on the Contractor for the refund of any excess amount paid to him, if as a result of such examination, any over-payment to him is discovered to have been made in respect of any work done or alleged to have been done by the Contractor, under the Contract. If any under-payment is discovered, the same shall be paid by the Employer to the Contractor. Such payments or recoveries, however, shall not carry any interest.

37.22 Recovery of money due to the Employer

All damages (including, without limitation, liquidated damages), costs, charges, expenses, debts, or sums for which the Contractor is liable to the Employer under any provision of the Contract may be deducted by the Employer from amount due to the Contractor under the Contract including, without limitation, and the Employer shall have the power to recover any balance not so deducted from amount due to the Contractor under any other contract between the Employer and the Contractor

When the Contractor has assigned to a third party the right to receive amount due, or, to become due, under the Contract to the Contractor or charged such amount in favour of a third party, the Employer's right to deduct damages (including without limitation liquidated damages), costs, charges, expenses, debts or sums for which the Contractor is liable to the Employer from amount due to the Contractor under the Contract shall be limited to the right expressed above.

37.23 TERMS OF PAYMENT:

All bills shall be submitted by prime bidder only (to whom contract has been awarded) to the authority mentioned in Preamble.

Subject to any deductions or recovery which the K RIDE may be entitled to make under contract, the Contractor will be entitled to be paid from time to time by way of 'on account payment' for supply of goods and 'progress payment' for works as in the opinion of the Engineer he has executed in terms of Contract.

ON ACCOUNT PAYMENT FOR SUPPLY ITEMS:

"On Account Payment" for supply of equipment, materials will be made on receipt of equipment/ materials, as indicated in Schedule **A, B, C, D, E, F, G, H, J, K, L, M & N** by K-RIDE. On Account payments made will subsequently be adjusted against payments due on Provisional Acceptance or Final Acceptance.

90% (Ninety Percent) of the value of each consignment shall be paid on receipt of materials at K-RIDE nominated site duly accepted by the Purchaser's Engineer and on production of the following documents:

- i) Acknowledgement of receipt of materials by Engineer.
- ii) Original Inspection certificates issued by Inspecting Officer.
- iii) Warranty/Manufacturer's inspection certificate that the materials are in accordance with the specifications of the contract.
- iv) Challan/ Invoice in duplicate.
- v) Indemnity Bond in the approved form (see Section 10).

10% (Ten percent) value of the supply items shall be paid after the successful completion of installation, testing & commissioning of whole system covering all materials and services as per schedule of works and issue of "Provisional Acceptance Certificate" by Engineer.

100% payment against Supply of Spares, Measuring **Instruments**, Tool Kits, and if any similar items, which is not part of installation and commissioning, will be made on receipt of materials, acceptance of the same and production of documents listed in Para 25.3.2 above.

PROGRESS PAYMENT FOR EXECUTION ITEMS:

Progress payment shall be made separately for each pure execution item/ sub-item of work given in the schedule **A, B, C, D, E, F, G, H, J, K, L, M & N** as follows.

75% (Seventy five percent) of the progress payment for the items in schedule of work for trenching and protective works and cable laying activities shall be made (cable trenching, laying, refilling, laying on culverts/bridges). The balance **15% (Fifteen percent)** of the progress payment for these items shall be made after terminations and end to end testing from relay room to function end are completed and jointly tested by the Engineer to his satisfaction.

For all other items of work (**schedule A, B, C, D, E, F, G, H, J, K, L, M & N**), progress payment for **90% (ninety percent)** value of the work/ services will be made after the works are completed to full satisfaction of K RIDE.

10% value of the works/ services completed shall be made after the issue of Provisional Acceptance Certificate and submission of all 'As made' documents of the relevant schedules.

ON ACCOUNT PAYMENT FOR SUPPLY AND INSTALLATION ITEMS:

'On Account' payments in respect of items involving supply and installation, 75% of the accepted rate of the schedule item will be paid on complete supply of the equipment listed in the schedule after due inspection and other formalities as applicable to other supply items in the schedule. The remaining 15% payment will be released only after successful installation of the equipment under the schedule. The balance 10% will be released on submission of all 'As made' documents of the relevant schedule.

FINAL PAYMENT:

On the basis of provisional acceptance certificate issued by the Engineer for all the works in all the sections covered in this contract, the final bill for the balance payment for each

	<p>item/sub-item of work shall be submitted by the Contractor along with a clear "NO CLAIM CERTIFICATE". The provisional acceptance certificate shall be issued by the Engineer only when he has accepted the work wholly after conducting the acceptance tests on each item of work.</p> <p>FINAL SETTLEMENT:</p> <p>On expiry of the warranty period and issue of certificate by Engineer-in-charge regarding satisfactory completion of work and final acceptance of the entire installations in all respect, Performance Guarantee/Security Deposit will be released to the Contractor after adjustment of any dues payable by the contractor.</p> <p>DEDUCTION FROM ON ACCOUNT PAYMENT BILLS</p> <p>All costs, damages or expenses, which K-RIDE may have paid or incurred, which under the provisions of contract are Contractor's obligations, will be deducted by K-RIDE from progress payment bills/invoice of Contractor, as and when it is understood that such an expense have been incurred or paid for.</p> <p>All such claims of K-RIDE shall, however, be duly supported by appropriate and certified vouchers, receipts or explanations as are available to enable the Contractor to identify such claims.</p>
<p>Clause-38/CC</p>	<p>The clause 38 of CC is substituted with the following para.</p> <p>38.1 Compensation Event:</p> <p>The risks referred to in Sub-Clause 11.4/PCC below, in so far as they directly affect the execution of the works in the Country, are:</p> <ul style="list-style-type: none"> (a) war, hostilities (whether war be declared or not), invasion, act of foreign enemies, (b) rebellion, terrorism, sabotage by persons other than the Contractor's Personnel, revolution, insurrection, military or usurped power, or civil war, within the Country, (c) riot, commotion or disorder within the Country by persons other than the Contractor's Personnel, (d) munitions of war, explosive materials, ionising radiation or contamination by radio-activity, within the Country, except as may be attributable to the Contractor's use of such munitions, explosives, radiation or radio-activity, (e) pressure waves caused by aircraft or other aerial devices travelling at sonic or supersonic speeds, (f) use or occupation by the Employer of any part of the Permanent Works, except as may be specified in the Contract, (g) design of any part of the Works by the Employer's Personnel or by others for whom the Employer is responsible.
<p>Clause-40/CC</p>	<p>The following paras are added to the Existing CC Clauses.</p> <p>CONTRACT PRICE</p>

	<p>40.1 The Contract Price</p> <p>Unless otherwise stated in the Special Conditions of Contract:</p> <ul style="list-style-type: none"> (a) the Contract Price shall be agreed or determined under Clause 35/PCC [Payment for Variation] and be subject to adjustments in accordance with the Contract; (b) the Contractor shall pay all taxes, duties and fees required to be paid by him under the Contract, and the Contract Price shall not be adjusted for any of these costs except as stated in Sub-Clause 34.7/PCC [Adjustments for Changes in Legislation]; (c) any quantities which may be set out in the Bill of Quantities or other Schedule are estimated quantities and are not to be taken as the actual and final quantities: <ul style="list-style-type: none"> (i) of the Works which the Contractor is required to execute, or (ii) for the purposes of New-Clause 7/PCC [Measurement and Evaluation]; and (d) the Contractor shall submit to the Engineer, within 28 days after the Commencement Date, a proposed breakdown of each lump sum price in the Schedules, if applicable. The Engineer may take account of the breakdown when preparing Payment Certificates, but shall not be bound by it. (e) It may be noted that in the event of the Contractor not making the due payments stated in sub-clause (b) above, and the concerned party puts up a claim with the Employer / Engineer, then the Employer / Engineer may make such payments and deduct the same from the sums due to the Contractor. <p>Change in Law</p> <p>Change in Law means the occurrence or coming into force of the following, at any time after the last Date of submission of tender:</p> <p>Any new Central and State Taxes, duties, cess, levies, which is imposed or any existing Central and State Taxes, duties, cess, levies & royalties are withdrawn after the due date of submission of tender and which impacts the performance of the contractor with increased cost or which results in extra financial gains to the contractor due to decreased cost in execution of contract. Such additional or reduced cost shall be certified by the Engineer after examining records provided by the contractor and shall be paid by or credited to the employer.</p> <p>However, change in the rate of any existing Central & State taxes (except GST), duties, cess, levies will not be considered as change in Law. Any risk of change in rate of existing Central and State Taxes (except GST), duties, cess, levies lies with and shall be borne by the Contractor.</p>
<p>Clause 42/CC</p>	<p>The following paras are replaced to the Existing CC Clauses.</p> <p>Advance Payment:</p> <p>42.1 Mobilization Advance</p> <p>The Employer shall make payment, as an Interest bearing advance for mobilization, when the Contractor submits a guarantee in accordance with this Sub-Clause. The total advance payment, the number and timing of instalments (if more than one), and the applicable currencies and proportions, shall be as stated in the Contract Data.</p> <p>Unless and until the Employer receives this guarantee, or if the total advance payment is not stated in the Contract Data, this Sub-Clause shall not apply.</p>

Mobilisation Advance	Installments
As per request of the Contractor subject to a maximum of 5%	Two Equal

The Engineer shall issue an interim payment certificate for the first installment of mobilisation advance after receiving an application for advance payment (under sub clause 37.1/PCC [Application for Interim Payment Certificates]) and after the Employer receives (i) the Performance Security in accordance with New-Clause 4.19/PCC [Performance Security] and (ii) a guarantee in amounts and currencies equal to the advance payment plus 5%. The next installment shall be released only when the contractor submits statement of having utilized the previous installment of mobilization advance and the Employer is satisfied that the utilization has been done in purposeful manner.

The Mobilization Advance shall be interest bearing and secured by BG equivalent to 105% of the advance amount

Mobilization advance payment: Comprises of the percentage of Accepted Contract Amount payable in the currencies and proportions in which the Accepted Contract Amount is payable and in installments as mentioned below;

Timing of Mobilization Advance Payment: First Installment within 21 (Twenty-one) days from the date of receipt of Bank guarantee acceptable to Employer.

Second Installment shall be released only when the contractor submits statement of having utilized the First Installment of mobilization Advance and the Employer is satisfied that the utilization has been done in purposeful manner. This shall be released within 21 days from the date of receipt of Bank guarantee acceptable to the Employer.

Interest on Advance Payment: At the rate of SBI MCLR+2% simple interest per annum on reducing balances. **The Interest rate is applicable from the date of submission of IPC / advance request by contractor.**

42.2 Advance against Plant and Machinery

This advance is payable in Indian Rupees/respective currencies as quoted in the Tender and accepted by the Employer against plant, equipment and machinery, provided the same have reached the site, or in the case of new items meant specifically for the works, firm purchase order has been placed and the invoices received. The plant and machinery shall be valued by the Engineer as follows:

- (a) New items: 80% of purchase price
- (b) Used items in working order: 80% of the depreciated value as assessed by the Engineer
- (c) Items valued at less than Rs. 1,000,000 (Rs. One million) per unit: Not to be considered

The total advance for Plant and Machinery shall be limited to 5% of the Contract Price and will carry an interest rate of SBI MCLR +2% simple interest per annum on reducing balances. It will be paid against submission of Bank Guarantees for 110% of advance value for each stage of advance to be given by each member of the consortium/JV in

proportion to their participation as per format given in section 10: Formats, from an Indian Schedule bank (excluding Cooperative Banks) or from a schedule Foreign Bank as defined in Section 2(e) of RBI Act 1934 read with Second Schedule. All bank Guarantees should be payable in Bangalore at the designated branch.

The Contractor should give an Undertaking that “No advance/loan has been taken against the subject plant & machinery from any other individual/financial institution/ organisation etc.” If a wrong/false undertaking is given, all the BGs can be forfeited and the contract is liable for termination under clause 49 of CC/PCC.

The Advance against Plant and Machinery will be paid within 30 days after receipt of the Contractor’s written request by the Employer which is recommended by the Engineer and submission of Bank Guarantees for procurement of plant and machinery.

Wherever Bank Guarantee or any other instrument is to be extended or fresh BG to be obtained, the cost towards getting extension of BG or fresh BG and other incidental charges will be on Contractor’s account

The Contractor;

(i) Shall submit the invoice and RC book (wherever applicable) in original, at the time of obtaining advance amount.

(ii) Shall furnish all four Bank Guarantees one time as per Condition of Contract.

(iii) Shall execute an Indemnity bond in favour of an Employer as against Third Party claim.

(iv) Shall not seek the possession of machinery brought to the site till the Advance obtained from Employer is fully settled.

The contractor should ensure that in the case of “Machinery and Equipment Advance” insurance and hypothecation in favour of the Employer should be done. The contractor should submit the proof of document related to Insurance and Hypothecation to the Engineer who will certify that the insurance and hypothecation to the Employer has been done in proper manner.

Employer shall be the sole custodian of the entire plant and machinery whenever the advance amount is given to the contractor and the same shall remain in the custody of Employer, till the Advance obtained from Employer, is fully settled.

The machinery and equipment brought to the site shall be exclusively intended for the execution of the work of Employer and shall not be removed without the consent of the Engineer.

The Contractor shall indemnify and hold harmless, the Employer against all actions, suits, proceedings, claims, damages, losses, expenses, demands pertaining to Advance amount towards plant and machinery.

The Contractor shall not remove any Equipment or Machinery from the site without the prior permission of the Engineer.

The contractor;

a) Shall not mortgage/create charge/hypothecate/encumber, in any way the machineries and equipment brought to site from the amounts advanced by Employer and shall give an undertaking in writing to that effect in favour of Employer.

b) Shall not sell or alienate any part/portion of machinery and equipment without the consent of Employer.

c) In the event of any such sale/alienation of any portion or part of machinery, Employer shall hold First Charge and the proceeds of such sale or alienation shall be appropriated towards the loan/ credit/ advance in respect of plant and machinery brought to the site by contractor.

42.3 Guarantees

Advances as mentioned in sub-clauses 42.1/PCC above, shall be payable against acceptable Bank Guarantees from banks as specified in New-clause 4.19/PCC. The guarantees shall be in the form as given in Section 10 (Contract Forms) or in another form approved by the Employer. The Contractor shall ensure that the guarantees are valid and enforceable until the advance amount paid as has been repaid, but its amount may be progressively reduced by the amount repaid by the Contractor as indicated in the Payment Certificates. If the terms of the guarantee specify its expiry date, and the advance payment has not been repaid by the date 28 days prior to the expiry date, the Contractor shall extend the validity of the guarantee until the advance payment has been repaid.

42.4 Recovery of Advances

Unless stated otherwise in the Contract Data, the advance payment shall be repaid through percentage deductions from the interim payments determined by the Engineer in accordance with Sub-Clause 37.3/PCC [Issue of Interim Payment Certificates], as follows:

- (a) deductions shall commence in the next interim Payment Certificate following that in which the total of all certified interim payments (excluding the advance payment) exceeds 15 percent of the Accepted Contract Amount Less Provisional Sums or passage of six months from the date of release of first advance payment, whichever is earlier; and
- (b) deductions shall be made for accrued interest on the advance up to the month and advance at the rate stated in the Contract Data of the amount of each Interim Payment Certificate (excluding the advance payment and deductions and repayments of retention) in the currencies and proportions of the advance payment until such time as the advance payment and accrued interest has been repaid; provided that the advance payment and accrued interest shall be completely repaid prior to the time when 85 percent of the Accepted Contract Amount has been certified for payment. If the amount of interim payment certificate is not sufficient for recovery of accrued interest or in the opinion of the Employer satisfactory progress is not being achieved by the contractor, then the contractor will have to deposit the accrued interest and return the mobilisation advance in part or in full as demanded by the Employer, failing which Employer shall have the right to encash the Bank Guarantee(s)

	<p>The contractor shall always have the option to start repayment earlier and/or to complete the repayment earlier than the due date.</p> <p>If the advance payment has not been repaid prior to the issue of the Taking-Over Certificate for the Works or prior to termination under Clause 49.0/PCC [Termination by Employer] or New-Clause 8/PCC [Force Majeure] (as the case may be), the whole of the balance then outstanding shall immediately become due and payable by the Contractor to the Employer.</p> <p>42.5 Repayment rate of Advance payment: 10% (Ten percent) of the amount of each running account bill payment.</p> <p>42.6 Advances to be Used only for this Work</p> <p>The advances shall be used by the Contractor strictly for the purpose of the Contract, and for the purpose for which they are paid. Under no circumstances, shall the advances be diverted for other purposes. Any such diversion shall be construed as a breach of the Contract and the Contractor shall be asked to return the advance at once and pay interest at 15% per annum till the advance is recovered back from him. The Contractor shall return the advance and pay the interest in one go without demur.</p> <p>Employer retains the right for any other remedy prescribed for breach of Contract in this regard.</p> <p>The Contractor, if required by the Engineer shall provide the details of utilisation of Mobilisation advance.</p>
<p>Clause 46/CC</p>	<p>The clause 46 of CC replaced with the following paras.</p> <p>Employer Taking Over</p> <p>46.1 Taking Over of the Works and Sections</p> <p>The Employer shall take over the Site and the Works within after issuing a certificate of Completion. Except as stated in Sub-Clause 30.5/PCC [Failure to Pass Tests on Completion], the Works shall be taken over by the Employer/Railway when (i) the Works have been completed in accordance with the Contract, including the matters described in Sub-Clause 26.4/PCC [Time for Completion] and except as allowed in sub-paragraph (a) below, and (ii) a Taking-Over Certificate for the Works has been issued, or is deemed to have been issued in accordance with this Sub-Clause.</p> <p>The Contractor may apply by notice to the Engineer for a Taking-Over Certificate not earlier than 14 days before the Works will, in the Contractor's opinion, be complete and ready for taking over. If the Works are divided into Sections, the Contractor may similarly apply for a Taking-Over Certificate for each Section.</p> <p>In case the works are to be taken over in accordance with sub-clause 30.6/PCC, the completed works shall be taken over by the Zonal Railway with the procedure specified by the Engineer.</p> <p>The Engineer shall, within 28 days after receiving the Contractor's application:</p> <p>(a) issue the Taking-Over Certificate to the Contractor, stating the date on which the Works or Section were completed in accordance with the Contract, except for any minor outstanding work and defects which will not substantially affect the use of the Works or</p>

Section for their intended purpose (either until or whilst this work is completed and these defects are remedied); or

- (b) reject the application, giving reasons and specifying the work required to be done by the Contractor to enable the Taking-Over Certificate to be issued. The Contractor shall then complete this work before issuing a further notice under this Sub-Clause.

If the Engineer fails either to issue the Taking-Over Certificate or to reject the Contractor's application within the period of 28 days, and if the Works or Section (as the case may be) are substantially in accordance with the Contract, the Taking-Over Certificate shall be deemed to have been issued on the last day of that period.

46.2 Taking Over of Parts of the Works

The Engineer may, at the sole discretion of the Employer, issue a Taking-Over Certificate for any part of the Permanent Works.

The Employer shall not use any part of the Works (other than as a temporary measure which is either specified in the Contract or agreed by both Parties) unless and until the Engineer has issued a Taking-Over Certificate for this part. However, if the Employer does use any part of the Works before the Taking-Over Certificate is issued:

- (a) the part which is used shall be deemed to have been taken over as from the date on which it is used,
- (b) the Contractor shall cease to be liable for the care of such part as from this date, when responsibility shall pass to the Employer, and
- (c) if requested by the Contractor, the Engineer shall issue a Taking-Over Certificate for this part.

After the Engineer has issued a Taking-Over Certificate for a part of the Works, the Contractor shall be given the earliest opportunity to take such steps as may be necessary to carry out any outstanding Tests on Completion. The Contractor shall carry out these Tests on Completion as soon as practicable before the expiry date of the relevant Defects Notification Period.

If the Contractor incurs Cost as a result of the Employer taking over and/or using a part of the Works, other than such use as is specified in the Contract or agreed by the Contractor, the Contractor shall (i) give notice to the Engineer and (ii) be entitled subject to Sub-Clause 4.1/SCC [Contractor's Claims] to payment of any such Cost, which shall be included in the Contract Price. After receiving this notice, the Engineer shall proceed in accordance with New—Clause 3.5/PCC [Determinations] to agree or determine this Cost and profit.

If a Taking-Over Certificate has been issued for a part of the Works (other than a Section), the delay damages thereafter for completion of the remainder of the Works shall be reduced. Similarly, the delay damages for the remainder of the Section (if any) in which this part is included shall also be reduced. For any period of delay after the date stated in this Taking-Over Certificate, the proportional reduction in these delay damages shall be calculated as the proportion which the value of the part so certified bears to the value of the Works or Section (as the case may be) as a whole. The Engineer shall proceed in accordance with New-Clause 3.5/PCC [Determinations] to agree or determine these proportions. The provisions of this paragraph shall only apply to the daily rate of delay

	<p>damages under Sub-Clause 26.8/PCC [Delay Damages], and shall not affect the maximum amount of these damages</p> <p>46.3 Interference with Tests on Completion</p> <p>If the Contractor is prevented, for more than 14 days, from carrying out the Tests on Completion by a cause for which the Employer/Engineer/other Contractors of the Employer, are responsible, the Employer shall be deemed to have taken over the Works or Section (as the case may be) on the date when the Tests on Completion would otherwise have been completed.</p> <p>The Engineer shall then issue a Taking-Over Certificate accordingly, and the Contractor shall carry out the Tests on Completion as soon as practicable, before the expiry date of the Defects Notification Period. The Engineer shall require the Tests on Completion to be carried out by giving 14 days' notice and in accordance with the relevant provisions of the Contract.</p> <p>If the Contractor suffers delay and/or incurs Cost as a result of this delay in carrying out the Tests on Completion, the Contractor shall give notice to the Engineer and shall be entitled subject to Sub-Clause 4.1/SCC [Contractor's Claims] to:</p> <ul style="list-style-type: none"> (a) an extension of time for any such delay, if completion is or will be delayed, under Sub-Clause 26.5/PCC [Extension of Time for Completion], and (b) payment of any such Cost, which shall be included in the Contract Price. <p>After receiving this notice, the Engineer shall proceed in accordance with New-Clause 3.5/PCC [Determinations] to agree or determine these matters.</p> <p>46.4 Surfaces Requiring Reinstatement</p> <p>Except as otherwise stated in a Taking-Over Certificate, a certificate for a Section or part of the Works shall not be deemed to certify completion of any ground or other surfaces requiring reinstatement.</p>
<p>Clause-49/CC</p>	<p>The following paras are added to the existing CC Clauses.</p> <p>TERMINATION BY EMPLOYER</p> <p>49.6 Notice to Correct</p> <p>If the Contractor fails to carry out any obligation under the Contract as mentioned below, but not limited to the obligations mentioned herein below, the Engineer/ Employer may serve the contractor with a 14 days' notice in writing calling upon the Contractor to make good the failure and to remedy it. If the Contractor;</p> <ul style="list-style-type: none"> (a) fails to comply with New-Clause 4.19/PCC [Performance Security], (b) abandons the Works or otherwise plainly demonstrates the intention not to continue performance of his obligations under the Contract, (c) without reasonable excuse fails to: <ul style="list-style-type: none"> (i) proceed with the Works in accordance with Clause 26/CC/PCC [Commencement, Delays and Suspension], or (ii) comply with a notice issued under New-Clause 5.5 [Rejection] or New-Clause 5.6/PCC [Remedial Work], within 28 days after receiving it, or

	<p>(iii) adhere to the agreed programme of work / activity on the critical path, by a margin of 10% of the stipulated period, or</p> <p>(iv) take steps to deploy competent and adequate number of personnel, and equipment to achieve progress as per agreed programme or</p> <p>(v) adhere to the instructions of Engineers/Employer persistently or</p> <p>(vi) comply any provision of the contract or</p> <p>(vii) provide the Engineer/Employer or their representative proper facilities for inspecting the works or any part thereof as required, under New-Clause 5.3/PCC (Inspection) and New-clause 5.4/PCC (Testing).</p> <p>(d) subcontracts the whole or major part of the Works or assigns the Contract without prior written consent of the Employer.,</p> <p>If the Contractor does not, within 14 days of receipt of notice under this sub-clause, proceed to make good his default in so far as the same is capable of being made good and carry on the work of complying with such direction as contained in the notice under sub clause 49.6/PCC to the entire satisfaction of the Engineer/Employer, the Employer shall be entitled to take action under sub-clause 49.6/PCC, 49.7/PCC below,</p> <p>In case of Contractor's repeated failure to adhere to the agreed program, and whereas the contractor has been served with a Notice to Correct under Clause 49.6 of PCC, if the Contractor approaches K-RIDE with a revised program with specific monthly physical and financial targets along with the proposal to deploy matching inputs in the form of manpower and other resources to the satisfaction of the Employer, then the Employer may consider whether to proceed with termination of the contract under Clause 49.7/PCC or to continue with the contract. However, the request to continue with the contract shall only be considered if the Contractor supports his earnestness to adhere to the revised program by submitting additional Performance Security in the form of Bank Guarantee(s) of specified number and value as decided by the Employer (total value of which will not exceed 10% of the contract price). The encashment of these additional Bank Guarantee(s) shall be linked with the non-achievement of agreed physical/financial targets agreed upon by the Contractor and the Employer.</p> <p>In case the Contractor's failure is limited to only some of the works, and in response to Notice to Correct under Clause 49.6 of PCC, the contractor approaches the Employer that such works may be offloaded from him and got executed through another agency and additional cost incurred, if any, should be recovered from his dues, the Employer, on being convinced that the anticipated additional cost for such works will not be substantial and can be recovered from the dues of the contractor and that such offloading will help in improving the overall progress of the project, may</p> <p>agree to such offloading without any repercussion on the performance security and/or additional bank guarantees, if any, submitted by the contractor. However, the Employer will not be under any compulsion to agree to such a request. The Contractor shall be informed of the LOA issued to other agency(ies) for such works.</p> <p>In case the Contractor does not approach the employer for offloading but the Employer is convinced that:</p> <p>(i) offloading of some works will help in improving the progress of the project;</p>
--	---

- (ii) termination/part termination of the contract at this stage will not be in the interest of the project;
- (iii) the anticipated additional cost for such works will not be substantial and can be recovered from the dues of the Contractor;

The Employer may issue 7 days' notice to the Contractor stating the resources required to be deployed against each work. If the Contractor fails to deploy the required resources as indicated in the notice, the employer shall offload such works and proceed with getting the works executed through other agency(ies). The Contractor shall be informed of the LOA issued to other agency(ies) for such works.

Offloading under the sub clause 49.6/PCC shall be without any repercussion on the performance security and/or additional bank guarantees, if any, submitted by the contractor. The Contractor would have no future claim on this account and the extra expenditure so incurred, if any, by the Employer in getting the offloaded work done, shall be recovered from subsequent payment certificates or any other dues of the Contractor

49.7 Termination by Employer

The Employer shall be entitled to terminate the Contract as a whole or any part or parts (as may be specified in the Notice of Termination under any of the above Sub-Clause issue) if the Contractor:

- (a) fails to comply with the directions contained in the notice under Sub-Clause 49.6/PCC [Notice to Correct],
- (b) becomes bankrupt or insolvent, goes into liquidation, has a receiving or administration order made against it by Court or Statutory Authority him, compounds with his creditors, or carries on business under a receiver, trustee or manager for the benefit of his creditors, or if any act is done or event occurs which (under applicable Laws) has a similar effect to any of these acts or events, or
- (c) gives or offers to give (directly or indirectly) to any person any bribe, gift, gratuity, commission or other thing of value, as an inducement or reward:
 - (i) for doing or forbearing to do any action in relation to the Contract, or
 - (ii) for showing or forbearing to show favour or disfavour to any person in relation to the Contract,

or if any of the Contractor's Personnel, agents or Subcontractors gives or offers to give (directly or indirectly) to any person any such inducement or reward as is described in this sub-paragraph (c). However, lawful inducements and rewards to Contractor's Personnel shall not entitle termination

In any of these events or circumstances, the Employer may, by Notice Terminate the contract with immediate effect.

The Employer's election to terminate the Contract shall not prejudice any other rights of the Employer, under the Contract or otherwise.

The Contractor shall remove all his plants and machinery from the site then leave the Site and deliver any required Goods, all Contractors' Documents, and other design documents made by or for him, to the Engineer within 7 days from the issue of Notice of Termination, failing which Delay Damages as prescribed for delay in completion of works shall be imposed as per provision of clause 26.8/PCC However, the Contractor shall use his best efforts to comply immediately with any reasonable instructions included in the notice of

Termination (i) for the assignment of any subcontract, and (ii) for the protection of life or property or for the safety of the Works.

After termination, the Employer may complete the Works and/or arrange for any other entities to do so. The Employer and these entities may then use any Goods, Contractor's Documents and other design documents made by or on behalf of the Contractor for completing the work.

49.8 Valuation at Date of Termination

As soon as practicable after a notice of termination under Sub-Clause 49.7/PCC [Termination by Employer] has taken effect, the Engineer shall proceed in accordance with Sub-Clause 3.5/PCC [Determinations] to agree or determine the value of the Works, Goods and Contractor's Documents, and any other sums due to the Contractor for work executed in accordance with the Contract. For this purpose, the contractor shall be notified the date for witnessing of measurements and handing over of the materials for which contractor has already been paid. In case the contractor fails to attend or send a representative even after such notice, the Engineer shall ex parte proceed with measurements of the works executed and taking over of plants and materials etc. for which payment has already been made to the contractor, which shall be treated as final.

49.9 Payment after Termination

After a notice of termination under Sub-Clause 49.7/PCC [Termination by Employer] has taken effect, the Employer may:

- (a) proceed in accordance with New-Clause 2.4/PCC [Employer's Claims],
- (b) encash the Performance Guarantee and forfeit the Performance Security:
 - i. In full including additional Performance Guarantee amount if any taken in terms of ITT and not due for release on the date of issue of termination letter, in case of termination of the contract as a whole; or
 - ii. in part/parts proportionate to the contract price of the bill/schedule to which the terminated part of work belongs i.e.

$$P = (A \times B) \div C \text{ where,}$$

P = Proportionate Bank Guarantee Amount

A = Contract Price of the particular bill/schedule to which the terminated part of work belongs

B = Performance Guarantee amount in terms of CC New- clause 4.19/PCC

C = Total Contract Price

Plus, additional Performance Guarantee amount if any taken in terms of ITT and not due for release on the date of issue of termination letter against that particular bill/Schedule to which the terminated part of the work belongs in case of termination in part/parts.

- (c) release any payment due to the contractor for works executed prior to termination and evaluation under clause 49.8/PCC (valuation at date of termination, however, if by this time the Contractor has failed to make a payment due to the Employer, the same will be deducted from the payment due and any balance remaining shall then be paid to the Contractor.)

49.10 Employer's Entitlement to Termination for Convenience

The Employer shall be entitled to terminate the Contract, at any time for the Employer's convenience, by giving notice of such termination to the Contractor. The termination shall take effect 28 days after the later of the dates on which the Contractor receives this notice or the Employer returns the Performance Security. The Employer shall not terminate the Contract under this Sub-Clause in order to execute the Works himself or to arrange for the Works to be executed by another contractor or to avoid a termination of the Contract by the Contractor.

After this termination, the Contractor shall proceed in accordance with the relevant clause and shall be paid in accordance with New-Clause 8/PCC [Payment and Release in case of Optional Termination].

49.11.1. Requirements after Termination

Upon Termination of this Agreement in accordance with the provisions of this clause 49, the Contractor shall comply with and conform to the following:

- (a) deliver to the Authority all Plant and Materials which shall have become the property of the Authority under this clause 49;
- (b) deliver all relevant records, reports, Intellectual Property and other licenses pertaining to the Works, other design documents and in case of Termination occurring after the Provisional Certificate has been issued, the "as built" Drawings for the Works;
- (c) transfer and/or deliver all Applicable Permits to the Authority to the extent permissible under Applicable Laws; and
- (d) vacate the Site within seven days.

49.11.2 Other rights and obligations of the Parties

Upon Termination for any reason whatsoever

- (a) property and ownership in all Materials, Plant and Works and the Railway Project shall, as between the Contractor and the Authority, vest in the Authority in whole, free from any and all Encumbrances; provided that the foregoing shall be without prejudice to Clause 49.11.3;
- (b) risk of loss or damage to any Materials, Plant or Works and the care and custody thereof shall pass from the Contractor to the Authority; and
- (c) the Authority shall be entitled to restrain the Contractor and any person claiming through or under the Agreement from entering upon the Site or any part of the Project except for taking possession of materials, stores, implements, construction plants and equipment of the Contractor, which have not been vested in the Authority in accordance with the provisions of this Agreement.

49.11.3 Payment on Termination

After termination under Sub-Clause-49.7/PCC the Employer shall return the Performance Security, and shall pay the Contractor an amount calculated and certified in accordance with the following conditions:

- A. The value of approved materials actually brought to the site and reasonably required to execute the works during next three months, as per approved programme, and

B. Value of work completed up to date by the Contractor at rates specified in the Contract, after taking into account any deductions, retentions, and setoff.

C. In addition, a sum not exceeding 2% (two percent) of the value of the work remaining incomplete on the date of Termination notice taking effect.

The payment as above are full compensation for termination under this clause and the Contractor has no claim for damages or other entitlements whether under the contract or otherwise.

In case of termination/ foreclosure of the Contract under whatsoever circumstances, any remaining tools, plants, equipment's and surplus materials of the Employer with the Contractor will be returned to the Employer at Employer's depot at the Contractor's cost. In case of the failure of the Contractor to do so, the Employer will be entitled to recover their cost from the Contractor from the amount becoming due to the Contractor or from any other amount due in any other contracts.

The decision of the Engineer of the amount to be recovered will be final decision and full credit at rates initially charged to the Contractor shall be allowed for such materials. Similarly, the Employer shall be entitled to recover the cost of the unreturned material, plants, equipment and tools from the Contractor, where such material have been supplied free of cost and plants, equipment and tools, free of cost or on lease basis to the Contractor as stipulated in the Contract.

49.12 Survival

Termination of this Contract

- a. shall not relieve the Contractor or the Employer of any obligations already incurred hereunder which expressly or by implication survives Termination hereof and
- b. except as otherwise provided in any provision of this Contract expressly limiting the liability of either party, shall not relieve either party of any obligations or liabilities for loss or damage to the other Party arising out of or caused by acts or omissions of such Party prior to the effectiveness of such Termination or arising out of such Termination

49.13 Corrupt or Fraudulent Practices

If the Employer determines that the Contractor has engaged in corrupt, fraudulent, collusive or coercive practices, in competing for or in executing the Contract, then the Employer may, after giving 14 days' notice to the Contractor, terminate the Contractor's employment under the Contract and expel him from the Site, and the provisions of Clause 49 CC/PCC shall apply as if such expulsion had been made under Sub-Clause 49.7/PCC.

For the purposes of this Sub-Clause:

- (a) "corrupt practice" means the offering, giving, receiving of soliciting of anything of "value to influence the action of a public official in the procurement process or in the Contract execution.
- (b) "fraudulent practice" means a misrepresentation of facts in order to influence a procurement process or the execution of the Contract to the detriment of the Employer, and includes collusive practice among Bidders (prior to or after bid submission) designed to establish bid prices at artificial non-competitive levels and to deprive the Employer of the benefits of free and open competition

	<p>(c) collusive practice” means a scheme or arrangement between two or more bidders, with or without the knowledge of the Employer, designed to establish bid prices at artificial, non-competitive levels.</p> <p>(d) “coercive practice” means harming or threatening to harm, directly or indirectly, persons or their property to influence their participation in the procurement process or affect the execution of a contract.</p>
<p>Clause 1/SCC</p>	<p>The following New-paras are added to the Existing SCC Clauses.</p> <p>1.1 Engagement of Staff and Labour</p> <p>Except as otherwise stated in the Specification, the Contractor shall make arrangements for the engagement of all staff and labour, local or otherwise, and for their payment, housing, feeding and transport.</p> <p>The Contractor is encouraged, to the extent practicable and reasonable, to employ staff and labor with appropriate qualifications and experience from sources within the Country.</p> <p>1.2 Rates of Wages and Conditions of Labour</p> <p>The Contractor shall pay rates of wages, and observe conditions of labour, which are not lower than those established for the trade or industry where the work is carried out. If no established rates or conditions are applicable, the Contractor shall pay rates of wages and observe conditions which are not lower than the general level of wages and conditions observed locally by employers whose trade or industry is similar to that of the Contractor.</p> <p>If the Employer is obliged to provide amenities or arrange payment of wages to contract labour employed by the contractor either directly or through sub-contractor under the contract on account of failures on the part the contractor to provide the amenities and / or arrange payment of wages to the contract labour as required of him under the provision of the applicable acts / rules made there under, the Engineer/Employer shall be at liberty without prejudice to the rights of Engineer/Employer under Section 20(2) and 21(4) of the Contract Labour (Regulation and Abolition) Act 1970 to recover the whole or part of the expenditure so incurred on the wages so paid by the Engineer/Employer/Railway from the security deposit and/or from any sum or sums due to the Contractor whether under this contract or any other contract.</p> <p>The Contractor shall inform the Contractor’s Personnel about their liability to pay personal income taxes in the Country in respect of such of their salaries, wages, allowances, and any benefits as are subject to taxes under the Laws of the Country for the time being in force, and the Contractor shall perform such duties in regard to such deductions thereof as may be imposed on him by such Laws.</p> <p>The Contractor shall keep the Employer indemnified in case any action is taken against the Employer by the competent authority on account of contravention of any of the provisions of any Act or rules made there-under, regulation or notifications including amendment. If the Employer is caused to pay or reimburse, such amounts as may be necessary to cause or observe, or for non-observance of the provisions stipulated in the notifications/bye laws/Acts/Rules/ regulations including amendments, if any, on the part of the Contractor, the Engineer/Employer shall have the right to deduct any money due to the contractor including his amount of performance security. The Employer/Engineer shall also have right to recover from the Contractor any sum required or estimated to be required for making good the loss or damage suffered by the Employer.</p>

The employees of the Contractor and the Sub-Contractor in no case shall be treated as the employees of the Employer at any point of time.

The Contractor shall duly comply with the provisions of the Apprentices Act 1961 (III of 1961), the rules made there under and the orders that may be issued from time to time under the said Act and the said Rules and on his failure or neglect to do so he shall be subject to all liabilities provide by the said Act and said Rules.

The Contractor and his Sub Contractors shall comply with all applicable Labour Laws, and should not employ Child Labour for construction and maintenance activities. The Contractor shall provide appropriate facilities for children in Construction Camp sites.

The Contractors shall not differentiate wages between men and women for work of equal value

1.3 Persons in the Service of Employer

The Contractor shall not recruit, or attempt to recruit, staff and labour from amongst persons in the service of the Employer or the Engineer

1.4 Labour Laws

The Contractor shall comply with all the relevant Labour Laws applicable to the Contractor's Personnel, including Laws relating to their employment, health, safety, welfare, immigration, and emigration, and shall allow them all their legal rights. The Contractor and his sub-contractors shall be responsible to ensure at his own cost, compliance to all laws, bye-laws, rules and regulations for the time being in force pertaining to the employment of local or imported labour and shall take all necessary precautions to ensure and preserve the health and safety of all staff employed directly or through sub-contractors or petty contractors on the works which shall include all the acts listed in Appendix – 1 but not limited to the same.

The Contractor shall require his employees to obey all applicable Laws, including those concerning safety at work.

During continuance of the Contract, the Contractor and his Sub-Contractors shall abide at all times by all existing labor enactments and rules made thereunder, regulations, notifications and bye laws of the State or Central government or local authority and any other labor laws (including rules), regulations, bye laws that may be passed or notification that may be issued under any labor law in future either by the State or the Central Government or the local authority. Salient features of some of the major labor laws that are applicable to construction industry are given in Appendix 1 to these Conditions of Contract

1.5 Working Hours

No work shall be carried out on the Site on locally recognized days of rest, or outside the normal working hours stated in the Contract Data, unless:

- (a) otherwise stated in the Contract,
- (b) the Engineer gives consent, or
- (c) the work is unavoidable, or necessary for the protection of life or property or for the safety of the Works, in which case the Contractor shall immediately advise the Engineer.
- (d) The Contractor, generally will have to carry out work during night hours also and in shifts unless specifically provided otherwise in the Contract. No increase in rates or extra payments shall be admissible for night work. Wherever night working is carried out by

Contractor, temporary lighting arrangements as per approved layout shall be provided, installed, maintained for the duration of the contract and removed after completion of work. Flashing lights to warn the traffic on roads shall be used at all times on all obstructions. No extra payment will be made for the provision of temporary lighting, flashing lights and for maintenance. It is to be noted that the works are being undertaken in an urban area.

- (e) Should there be complaints received by members of the public regarding excessive noise or vibration, etc. especially at night, and if such complaints are valid, then the contractor shall take remedial measures to prevent such nuisance. No extra payment will be made to the contractor for the provision of such measures.
- (f) Working hours during the Defect liability period will be curtailed when certain system become operational

1.6 Facilities for Staff and Labour

Except as otherwise stated in the Specification, the Contractor shall provide and maintain all necessary accommodation and welfare facilities for the Contractor's Personnel. The Contractor shall also provide facilities for the Employer's Personnel as stated in the Specification.

The Contractor shall not permit any of the Contractor's Personnel to maintain any temporary or permanent living quarters within the structures forming part of the Permanent Works.

1.7 Health and Safety

The Contractor shall at all times take all reasonable precautions to maintain the health and safety of the Contractor's Personnel. In collaboration with local health authorities, the Contractor shall ensure that medical staff, first aid facilities, sick bay and a standing arrangement for ambulance service are available at a phone call at all times at the Site and at any accommodation for Contractor's and Employer's Personnel, and that suitable arrangements are made for all necessary welfare and hygiene requirements and for the prevention of epidemics.

In the event of any outbreak of illness of an epidemic nature, the Contractor shall comply with and carry out such regulations, orders and requirements as may be made by the Government or the local medical or sanitary authorities, for the purpose of dealing with and overcoming the same. The Contractor shall appoint an accident prevention officer at the Site, responsible for maintaining safety and protection against accidents. This person shall be qualified for this responsibility, and shall have the authority to issue instructions and take protective measures to prevent accidents. Throughout the execution of the Works, the Contractor shall provide whatever is required by this person to exercise this responsibility and authority.

The Contractor shall send, to the Engineer, details of any accident as soon as practicable after its occurrence.

HIV-AIDS Prevention. The Contractor shall conduct an HIV-AIDS awareness programme via an approved service provider, and shall undertake such other measures as are specified in this Contract to reduce the risk of the transfer of the HIV virus between and among the Contractor's Personnel and the local community, to promote early diagnosis and to assist affected individuals

Epidemics

In the event of any outbreak of illness of an epidemic nature, the Contractor shall comply with and carry out such regulations, orders and requirements as may be made by the Government or the local medical or sanitary authorities, for the purpose of dealing with and overcoming the same.

Records of Safety and Health

The Contractor shall maintain such records and make such reports concerning safety, health and welfare of persons and damage to property as the Engineer may from time to time prescribe.

Submission of Returns

The contractor shall be responsible for timely submission of all returns and statements to the concerned authorities in full compliance of all rules, bye-laws and regulations for the time being in force.

The Contractor shall throughout the contract (including the Defects Notification Period): (i) conduct Information, Education and Consultation Communication (IEC) campaigns, at least every other month, addressed to all the Site staff and labor (including all the Contractor's employees, all Sub-Contractors and Consultants' employees, and all truck drivers and crew making deliveries to Site for construction activities) and to the immediate local communities, concerning the risks, dangers and impact, and appropriate avoidance behavior with respect to of Sexually Transmitted Diseases (STD)—or Sexually Transmitted Infections (STI) in general and HIV/AIDS in particular; (ii) provide male or female condoms for all Site staff and labor as appropriate; and (iii) provide for STI and HIV/AIDS screening, diagnosis, counseling and referral to a dedicated national STI and HIV/AIDS program, (unless otherwise agreed) of all Site staff and labor.

The Contractor shall include in the program to be submitted for the execution of the Works under Sub-Clause 25.3 an alleviation program for Site staff and labour and their families in respect of Sexually Transmitted Infections (STI) and Sexually Transmitted Diseases (STD) including HIV/AIDS. The STI, STD and HIV/AIDS alleviation program shall indicate when, how and at what cost the Contractor plans to satisfy the requirements of this Sub-Clause and the related specification. For each component, the program shall detail the resources to be provided or utilized and any related sub-contracting proposed. The program shall also include provision of a detailed cost estimate with supporting documentation. Payment to the Contractor for preparation and implementation this program shall not exceed the Provisional Sum dedicated for this purpose.

1.8 Contractor's Superintendence

Throughout the execution of the Works, and as long thereafter as is necessary to fulfil the Contractor's obligations, the Contractor shall provide all necessary superintendence to plan, arrange, direct, manage, inspect and test the work.

Superintendence shall be given by a sufficient number of persons having adequate knowledge of the language for communications (defined in Sub-Clause 3/CC [Law and Language]) and of the operations to be carried out (including the methods and techniques required, the hazards likely to be encountered and methods of preventing accidents), for the satisfactory and safe execution of the Works.

The Contractor shall employ the key personnel named in the Schedule of Personnel as referred to in the Contract Data to carry out the functions stated in the Schedule or other

personnel approved by the Engineer. The Engineer will approve any proposed replacement of key personnel only if their qualifications, abilities and relevant experience are substantially equal to or better than those of the personnel listed in the Schedule.

The Contractor shall not employ any retired government Gazetted officer, who has either not completed one year after the date of retirement, or has not obtained permission to employment with the Contractor

1.9 Contractor's Personnel

The Contractor's Personnel shall be appropriately qualified, skilled and experienced in their respective trades or occupations. The Engineer may require the Contractor to remove (or cause to be removed) any person employed on the Site or Works, including the Contractor's Representative if applicable, who:

- (a) persists in any misconduct or lack of care,
- (b) carries out duties incompetently or negligently,
- (c) fails to conform with any provisions of the Contract, or
- (d) persists in any conduct which is prejudicial to safety, health, or the protection of the environment.

If the Engineer asks the Contractor to remove a person who is a member of the Contractor's staff or his work force stating the reasons, the Contractor shall ensure that the person leaves the Site within seven (7) days and has no further connection with the work in the Contract. The replacement person shall be appointed within fourteen (14) days of the notification by the Engineer.

A reasonable proportion of the Contractor's Superintending Staff shall have a working knowledge of the English language or the Contractor shall have available on site at all times a sufficient number of competent interpreters to ensure the proper transmission of instructions and information. If appropriate, the Contractor shall then appoint (or cause to be appointed) a suitable replacement person

1.10 Records of Contractor's Personnel and Equipment

The Contractor shall submit, to the Engineer, details showing the number of each class of Contractor's Personnel and of each type of Contractor's Equipment on the Site. Details shall be submitted each calendar month, in a form approved by the Engineer, until the Contractor has completed all work which is known to be outstanding at the completion date stated in the Taking-Over Certificate for the Works

1.11 Disorderly Conduct

The Contractor shall at all times take all reasonable precautions to prevent any unlawful, riotous or disorderly conduct by or amongst the Contractor's Personnel, and to preserve peace and protection of persons and property on and near the Site

1.12 Foreign Personnel

The Contractor may bring in to the country any foreign personnel who are necessary for the execution of the Works to the extent allowed by the applicable Laws. The Contractor shall ensure that these personnel are provided with the required residence visas and work permits. The Employer will, without any financial liability, if requested by the Contractor, use his best endeavours in a timely and expeditious manner to assist the Contractor in

obtaining any local, state, national, or government permission required for bringing in the Contractor's personnel.

The Contractor shall be responsible for the return of these personnel to the place where they were recruited or to their domicile. In the event of the death in the Country of any of these personnel or members of their families, the Contractor shall similarly be responsible for making the appropriate arrangements for their return or burial. Contractor shall also be responsible for any legal liabilities during their stay.

1.13 Supply of Foodstuffs

The Contractor shall arrange for the provision of a sufficient supply of suitable food as may be stated in the Specification at reasonable prices for the Contractor's Personnel for the purposes of or in connection with the Contract

1.14 Supply of Water

The Contractor shall, having regard to local conditions, provide on the Site an adequate supply of drinking and other water for the use of the Contractor's Personnel

1.15 Measures against Insect and Pest Nuisance

The Contractor shall at all times take the necessary precautions to protect the Contractor's Personnel employed on the Site from insect and pest nuisance, and to reduce their danger to health. The Contractor shall comply with all the regulations of the local health authorities, including use of appropriate insecticide

The Contractor shall provide his staff and labour with suitable prophylactics for the prevention of malaria, and take steps to prevent the formation of stagnant pools of water. He shall comply with all the regulations of the local health authorities in these respects and shall in particular arrange to spray thoroughly with approved insecticides all buildings erected on the site such treatment shall be carried out at least once a year or as instructed by the Engineer. The Contractor shall warn his staff and labour of the dangers of diseases like Malaria, Filariasis and other contagious diseases etc. and also regarding, Scorpions, Snakes, Wild animals etc. and preventive actions required to be taken by the labour and staff.

1.16 Alcoholic Liquor or Drugs

The Contractor shall not, otherwise than in accordance with the Laws of the Country, import, sell, give barter or otherwise dispose of any alcoholic liquor or drugs, or permit or allow importation, sale, gift barter or disposal thereto by Contractor's Personnel.

1.17 Arms and Ammunition

The Contractor shall not give, barter, or otherwise dispose of, to any person, any arms or ammunition of any kind, or allow Contractor's Personnel to do so.

1.18 Festivals and Religious Customs

The Contractor shall respect the Country's recognized festivals, days of rest and religious or other customs

1.19 Funeral Arrangements

The Contractor shall be responsible, to the extent required by local regulations, for making any funeral arrangements for any of his local employees who may die while engaged upon the Works.

1.20 Prohibition of Forced or Compulsory Labour

The contractor shall not employ "forced or compulsory labour" in any form. "Forced or compulsory labour" consists of all work or service, not voluntarily performed, that is extracted from an individual under threat of force or penalty.

1.21 Prohibition of Harmful Child Labour

The Contractor shall not employ any child to perform any work that is economically exploitative, or is likely to be hazardous to, or to interfere with, the child's education, or to be harmful to the child's health or physical, mental, spiritual, moral, or social development.

1.22 Employment Records of Workers

The Contractor shall keep complete and accurate records of the employment of labour at the Site. The records shall include the names, ages, genders, hours worked and wages paid to all workers. These records shall be summarized on a monthly basis and shall be available for inspection by the Engineer during normal working hours. These records shall be included in the details to be submitted by the Contractor under Sub-Clause 1.10/SCC of PCC [Records of Contractor's Personnel and Equipment].

In addition to the above, the Contractor shall register his firm/company etc. on website 'www.shramikkalyan.indianrailways.gov.in' and upload requisite details of labour and their payment in this portal. These details shall be available in public domain. The Registration/ updation on Portal shall be done as under:

- (a) Contractor shall apply for onetime registration of his company/firm etc. in the Shramikkalyan portal with requisite details subsequent to issue of Letter of Acceptance. Employer/Engineer shall approve the contractor's registration in the portal within 7 days of receipt of such request.
- (b) Contractor once approved by any Employer/Engineer, can create password with login ID (PAN No.) for subsequent use of portal for all LoAs issued in his favour.
- (c) The contractor once registered on the portal, shall provide details of his Letter of Acceptances (LoA) / Contract Agreements on shramikkalyan portal within 15 days of issue of any LoA for approval of concerned Employer/Engineer. Employer/Engineer shall update (if required) and approve the details of LoA filled by contractor within 7 days of receipt of such request.
- (d) After approval of LoA by Employer/Engineer, contractor shall fill the salient details of contract labours engaged in the contract and ensure updating of each wage payment to them on shramikkalyan portal on monthly basis.
- (e) It shall be mandatory upon the contractor to ensure correct and prompt uploading of all salient details of engaged contractual labour & payments made thereof after each wage period.

	<p>While processing payment of any 'Interim Payment Certificate' or 'Final Payment Certificate' or release of 'Advances' or 'Performance Guarantee / Security deposit', contractor shall submit a certificate to the Engineer or Engineer's representatives that "I have uploaded the correct details of contract labours engaged in connection with this contract and payments made to them during the wage period in Railway's Shramikkalyan portal at 'www.shramikkalyan.indianrailways.gov.in' till ____Month, ____Year."</p>
<p>Clause Price adjustment/ Contract data</p>	<p>REPLACE THE SUB-CLAUSE OF PRICE ADJUSTMENT IN CONTRACT DATA WITH THE FOLLOWING:</p> <p>PRICE VARIATION CLAUSE (PVC) Adjustment for changes in cost for the work of S&T utility shifting etc.. of suburban corridor-4</p> <p>Contract price shall be adjusted for increase or decrease in rates and prices of labour, materials, fuels and lubricants in accordance with the following principles and procedures and as per formula given here under.</p> <p>The amounts payable to the Contractor shall be adjusted for rises or falls in the cost of labour, Goods and other inputs to the Works, by the addition or deduction of the amounts determined by the formulae prescribed in this Sub-Clause. To the extent that full compensation for any rise or fall in Costs is not covered by the provisions of this or other Clauses, the Accepted Contract Amount shall be deemed to have included amounts to cover the contingency of other rises and falls in costs.</p> <p>(A) Adjustment Formula</p> <p>The adjustment to be applied to the amount otherwise payable to the Contractor, as valued in accordance with the appropriate Schedule and certified in Payment Certificates, shall be determined from formulae in which the Contract Price is payable. No adjustment is to be applied to work valued on the basis of Cost or current prices. The formulae shall be of the following:</p> <p>Following expressions and meanings are assigned to the work done during each month.</p> <p>R=Total value of work done during the month shall include the value of materials on which secured advance has been granted, if any during the month less the value of materials in respect of which the secured advance has been recovered, if any, during the month. This excludes the cost of work on items for which rates were fixed under Variations Clause 35/PCC for which the escalation will be regulated as mutually agreed at the time of fixation of rate.</p> <p>Following expressions and meanings are assigned to the work done during each month.</p> <p>$V=VL +VF+VM+VP+VS+VC$ Where</p> <p>V = Total adjustment on account of all components.</p> <p>VL = Adjustment on account of labour component.</p> <p>VF = Adjustment on account of High speed diesel component.</p> <p>VM = Adjustment on account of other materials component.</p>

VP = Adjustment on account of Plant, machinery and spares.

VS = Adjustment on account of steel component.

VC = Adjustment on account of cement component.

Fixed cost co-efficient to total cost = 0.15

Adjustment for labour Component:

Price adjustment for increase or decrease in the cost due to labour shall be paid in accordance with following formula. (Base: 2001=100).

$VL = R \times PL \times [(Li - Lo)/Lo]$ Where

VL= Increase or decrease in the cost of work during the month under consideration due to change in rates for local labour

Lo =. The average consumer price index for industrial workers for Bangalore Centre as applicable for the month of submission of the tender as published by Labour Bureau, Ministry of Labour, GOI.

Li = The average consumer price index for industrial workers for Bangalore Centre during the 'month under consideration' as published by Labour Bureau, Ministry of Labour, GOI.

PL (cost co-efficient of labour to the total cost) = 0.20

Adjustment for High Speed Diesel component:

Price adjustment for increase or decrease in the cost of High Speed Diesel component shall be paid in accordance with following formula (Base: 2011-12=100).

$VF = R \times PF \times [(Fi - Fo)/Fo]$ where

VF = Increase or decrease in the cost of work during the month under consideration due to change in rates for High-Speed Diesel components.

Fo = The all-India average wholesale price index for High-Speed Diesel component as applicable for the month of submission of the tender as published by Office of the Economic Adviser.

Fi = The all-India average wholesale price index for High-Speed Diesel component for the 'month under consideration' as published by Office of the Economic Adviser.

PF (cost co-efficient of fuel and lubricants to the total cost) = 0.08

Adjustment on account of other materials component:

Price adjustment for increase or decrease in the cost of other materials component shall be paid in accordance with following formula (Base: 2011-12=100).

$VM = R \times PM \times [(Mi - Mo)/Mo]$ where

VM = Increase or decrease in the cost of work during the month under consideration due to change in rates for other material components.

Mo = the whole sale price index for all commodities as applicable for the month of submission of the tender as published by Office of the Economic Adviser.

Mi = The whole sale price index for all commodities during the month preceding the 'month under consideration' as published by Office of the Economic Adviser.

PM= (cost co-efficient of other materials to the total cost) =0.10

Adjustment on account of Plant, machinery and spares:

Price adjustment for increase or decrease in the cost of plant, machinery and spares component shall be paid in accordance with following formula (Base: 2011-12=100).

$VP = R \times PP \times [(Pi - Po)/Po]$ where

VP = Increase or decrease in the cost of work during the month under consideration due to change in rates for plant, machinery and spares components.

Po = the wholesale price index for manufacture of machinery for mining, quarrying and construction as applicable for the month of submission of the tender as published by Office of the Economic Adviser.

Pi = the wholesale price index for manufacture of machinery for mining, quarrying and construction during the month preceding the 'month under consideration' as published by Office of the Economic Adviser.

PP (cost co-efficient of Plant, machinery and spares to the total cost) =0.12

Adjustment on account of steel component:

Price adjustment for increase or decrease in the cost of Steel shall be paid in accordance with following formula. (Base: 2011-12=100)

$VS = R \times PS \times [(Si - So)/So]$ where

VS= Increase or decrease in the cost of work during the month under consideration due to change in rates for Structural Steel / TMT rebars / MS Steel / Pre-stressing strands.

So = the all India average wholesale price index for Mild Steel – Long products as applicable for the month of submission of the tender as published by Office of the Economic Adviser.

Si = the all India average wholesale price index for Mild Steel – Long products for the month preceding the 'month under consideration' as published by Office of the Economic Adviser.

PS (cost co-efficient of steel to the total cost) =0.23

Adjustment on account of cement component:

Price adjustment for increase or decrease in the cost of cement shall be paid in accordance with following formula. (Base: 2011-12=100)

$VC = R \times PC \times [(Ci - Co)/Co]$ where

VC= Increase or decrease in the cost of work during the month under consideration due to change in rates for cement component.

Co = The all India average wholesale price index for Ordinary Portland Cement as applicable for the month of submission of the tender as published by Office of the Economic Adviser.

Ci = The all India average wholesale price index for Ordinary Portland Cement for the month preceding the 'month under consideration' as published by Office of the Economic Adviser.

PC (cost co-efficient of Cement to the total cost) = 0.12

1. Applicability: Price Variation Clause (PVC) shall be applicable only in tender having advertised value above Rs. 2 Crores and having completion period above 12 months. Provided further that, in a contract where PVC is applicable, following shall be outside the purview of price adjustments (i.e. shall be excluded from the gross value of the work for the purpose of price variation):
 - a) Materials supplied by KRIDE to the Contractors, either free or at fixed rate;
 - b) Any extra item(s) included in subsequent variation falling outside the purview of the Bill(s) of Quantities of tender, under clause 35 of these particular conditions of contract, unless applicability of PVC and 'Base Month' has been specially agreed, while fixing the rates of such extra item(s).
2. Base Month: The Base Month for 'Price Variation Clause' shall be taken as the one month prior to closing of tender, unless otherwise stated elsewhere. The quarter for applicability of PVC shall commence from the month following the Base month. The Price Variation shall be based on the average Price Index of the quarter under consideration.
3. Validity: Rates accepted by Railway Administration shall hold good till completion of work and no additional individual claim shall be admissible except:
 - (a) Payment/recovery for increase/decrease in GST on works contract or imposition/removal of any tax/cess on Works Contract as per tender conditions,
 - (b) Payment/recovery for overall market situation as per Price Variation Clause given hereunder.
4. Components of various items in a contract on which variation in prices be admissible, shall be steel, cement, ferrous material, non-ferrous material, insulators, zinc and other materials, labour, plant & machinery, fuel, explosives, detonators etc. Adjustment for variation in prices of these items shall be determined in the manner prescribed.
5. No price variation shall be admissible for fixed components.
6. The percentages of various components in various type of works shall be as specified for all item (s)/ Bill(s) of Quantities in tender document and the same shall be fixed as per table & classifications given below:

SIGNALING & TELECOMMUNICATION WORKS:

1. The following expressions and meanings are assigned to the value of the work done for signalling and telecommunication works:

SIGWK = Value of signalling works for a stage payment of the item signalling works; INVSIG = Value of inventory for signalling works for a stage payment of the item inventory for signalling works;

INTGTESTSIG = Value of integrated testing and commission for signalling works of the Railway Project;

COMWK= Value of telecommunication works for a stage payment of the item telecommunication works; INVCOM = Value of inventory for telecommunication works for a stage payment of the item inventory for telecommunication works; and

INTGTESTCOM = Value of integrated testing and commission for telecommunication works of the Railway Project

2. Price adjustment for changes in cost of signalling works and telecommunication works shall be paid in accordance with the following formula:

i.
$$V_{SIGWK} = 0.85 \text{ SIGWK} \times [\text{PELEX} \times (\text{ELEX}_i - \text{ELEX}_o) / \text{ELEX}_o + \text{POFC} \times (\text{OFC}_i - \text{OFC}_o) / \text{OFC}_o + \text{PLB} \times (\text{LBI} - \text{LBO}) / \text{LBO} + \text{POTH} \times (\text{OTHi} - \text{OTHo}) / \text{OTHo} + \text{S30C} \times (\text{P30Ci} - \text{P30Co}) / \text{P30Co} + \text{S24C} \times (\text{P24Ci} - \text{P24Co}) / \text{P24Co} + \text{S19C} \times (\text{P19Ci} - \text{P19Co}) / \text{P19Co} + \text{S12C} \times (\text{P12Ci} - \text{P12Co}) / \text{P12Co} + \text{S9C} \times (\text{P9Ci} - \text{P9Co}) / \text{P9Co} + \text{S6C} \times (\text{P6Ci} - \text{P6Co}) / \text{P6Co} + \text{S4C} \times (\text{P4Ci} - \text{P4Co}) / \text{P4Co} + \text{S2C} \times (\text{P2Ci} - \text{P2Co}) / \text{P2Co} + \text{S12C2.5} \times (\text{P12C2.5i} - \text{P12C2.5o}) / \text{P12C2.5o} + \text{S2C2.5} \times (\text{P2C2.5i} - \text{P2C2.5o}) / \text{P2C2.5o} + \text{S2C25} \times (\text{P2C25i} - \text{P2C25o}) / \text{P2C25o} + \text{QC} \times (\text{PQCi} - \text{PQCo}) / \text{PQCo};$$

ii.
$$V_{INVSIG} = 0.85 \text{ SIGWK} \times [\text{PELEX} \times (\text{ELEX}_i - \text{ELEX}_o) / \text{ELEX}_o + \text{POTH} \times (\text{OTHi} - \text{OTHo}) / \text{OTHo}];$$

iii.
$$V_{INTGTESTSIG} = 0.85 \text{ INTGTESTSIG} \times [\text{PLB} \times (\text{LBI} - \text{LBO}) / \text{LBO} + \text{POTH} \times (\text{OTHi} - \text{OTHo}) / \text{OTHo}];$$

iv.
$$V_{COMWK} = 0.85 \text{ COMWK} \times [\text{PELEX} \times (\text{ELEX}_i - \text{ELEX}_o) / \text{ELEX}_o + \text{POFC} \times (\text{OFC}_i - \text{OFC}_o) / \text{OFC}_o + \text{PLB} \times (\text{LBI} - \text{LBO}) / \text{LBO} + \text{POTH} \times (\text{OTHi} - \text{OTHo}) / \text{OTHo} + \text{S30C} \times (\text{P30Ci} - \text{P30Co}) / \text{P30Co} + \text{S24C} \times (\text{P24Ci} - \text{P24Co}) / \text{P24Co} + \text{S19C} \times (\text{P19Ci} - \text{P19Co}) / \text{P19Co} + \text{S12C} \times (\text{P12Ci} - \text{P12Co}) / \text{P12Co} + \text{S9C} \times (\text{P9Ci} - \text{P9Co}) / \text{P9Co} + \text{S6C} \times (\text{P6Ci} - \text{P6Co}) / \text{P6Co} + \text{S4C} \times (\text{P4Ci} - \text{P4Co}) / \text{P4Co} + \text{S2C} \times (\text{P2Ci} - \text{P2Co}) / \text{P2Co} + \text{S12C2.5} \times (\text{P12C2.5i} - \text{P12C2.5o}) / \text{P12C2.5o} + \text{S2C2.5} \times (\text{P2C2.5i} - \text{P2C2.5o}) / \text{P2C2.5o} + \text{S2C25} \times (\text{P2C25i} - \text{P2C25o}) / \text{P2C25o} + \text{QC} \times (\text{PQCi} - \text{PQCo}) / \text{PQCo} + \text{PCEQP} \times (\text{CEQP}_i - \text{CEQP}_o) / \text{CEQP}_o];$$

v.
$$V_{INVCOM} = 0.85 \text{ SIGWK} \times [\text{PELEX} \times (\text{ELEX}_i - \text{ELEX}_o) / \text{ELEX}_o + \text{PCEQP} \times (\text{CEQP}_i - \text{CEQP}_o) / \text{CEQP}_o + \text{POTH} \times (\text{OTHi} - \text{OTHo}) / \text{OTHo}];$$

vi.
$$V_{INTGTESTCOM} = 0.85 \text{ INTGTESTCOM} \times [\text{PLB} \times (\text{LBI} - \text{LBO}) / \text{LBO} + \text{POTH} \times (\text{OTHi} - \text{OTHo}) / \text{OTHo}];$$

Where

VSIGWK = Increase or decrease in the cost of signalling works during the period under consideration due to changes in the rates for relevant components as specified in subparagraph (h);

VINVSIG = Increase or decrease in the cost of inventory for signalling during the period under consideration due to changes in the rates for relevant components as specified in subparagraph (h);

VINTGTESTSIG = Increase or decrease in the cost of integrated testing and commissioning of signalling works of the Railway Project during the period under consideration due to changes in the rates for relevant components as specified in sub-paragraph (h);

VCOMWK = Increase or decrease in the cost of communication works during the period under consideration due to changes in the rates for relevant components as specified in subparagraph (h);

VINVCOM = Increase or decrease in the cost of inventory for telecommunications works during the period under consideration due to changes in the rates for relevant components as specified in sub-paragraph (h);

VINTGTESTCOM = Increase or decrease in the cost of integrated testing and commissioning of telecommunication works of the Railway Project during the period under consideration due to changes in the rates for relevant components as specified in subparagraph (h);

PCEQP, PELEX, PIC, PLB, POFC, and POTH are the percentages of communication equipment, electronics, PVC insulated cables, labour, optical fibre cables, and other materials respectively;

CEQP_o = The wholesale price index as published by the Ministry of Commerce and Industry, Government of India (hereinafter called "WPI") for communication equipment for the month of the Base Month;

CEQP_i = The WPI for communication equipment for the average price index of the 3 months of the quarter under consideration;

ELEX_o = The WPI for electronics for the month of the Base Month;
ELEX_i = The WPI for electronics for the average price index of the 3 months of the quarter under consideration;

P30C_i = Price payable per Km as adjusted in accordance with price variation Clause for size 30C x 1.5 sq mm signalling cable

P30C_o = Price per Km of cable as per purchase order/ Contract agreement.

S30C = Percentage of size 30C x 1.5 sq mm signalling cable shall govern the price adjustment of the contract price for signalling and telecommunication works.

P24Ci = Price payable per Km as adjusted in accordance with price variation Clause for size 24C x 1.5 sq mm signalling cable

P24Co = Price per Km of cable as per purchase order/ Contract agreement.

S24C = Percentage of size 24C x 1.5 sq mm signalling cable shall govern the price adjustment of the contract price for signalling and telecommunication works.

P19Ci = Price payable per Km as adjusted in accordance with price variation Clause for size 19C x 1.5 sq mm signalling cable

P19Co = Price per Km of cable as per purchase order/ Contract agreement.

S19C = Percentage of size 19C x 1.5 sq mm signalling cable shall govern the price adjustment of the contract price for signalling and telecommunication works.

P12Ci = Price payable per Km as adjusted in accordance with price variation Clause for size 12C x 1.5 sq mm signalling cable

P12Co = Price per Km of cable as per purchase order/ Contract agreement.

S12C = Percentage of size 12C x 1.5 sq mm signalling cable shall govern the price adjustment of the contract price for signalling and telecommunication works.

P9Ci = Price payable per Km as adjusted in accordance with price variation Clause for size 9C x 1.5 sq mm signalling cable

P9Co = Price per Km of cable as per purchase order/ Contract agreement.

S9C = Percentage of size 9C x 1.5 sq mm signalling cable shall govern the price adjustment of the contract price for signalling and telecommunication works.

P6Ci = Price payable per Km as adjusted in accordance with price variation Clause for size 6C x 1.5 sq mm signalling cable

P6Co = Price per Km of cable as per purchase order/ Contract agreement.

S6C = Percentage of size 6C x 1.5 sq mm signalling cable shall govern the price adjustment of the contract price for signalling and telecommunication works.

P4Ci = Price payable per Km as adjusted in accordance with price variation Clause for size 4C x 1.5 sq mm signalling cable

P4Co = Price per Km of cable as per purchase order/ Contract agreement.

S4C = Percentage of size 4C x 1.5 sq mm signalling cable shall govern the price adjustment of the contract price for signalling and telecommunication works.

P2Ci = Price payable per Km as adjusted in accordance with price variation Clause for size 2C x 1.5 sq mm signalling cable

P2Co = Price per Km of cable as per purchase order/ Contract agreement.

S2C = Percentage of size 2C x 1.5 sq mm signalling cable shall govern the price adjustment of the contract price for signalling and telecommunication works.

P12C2.5i = Price payable per Km as adjusted in accordance with price variation Clause for size 12C x 2.5 sq mm signalling cable

P12C2.5o = Price per Km of cable as per purchase order/ Contract agreement.

S12C2.5 = Percentage of size 12C x 2.5 sq mm signalling cable shall govern the price adjustment of the contract price for signalling and telecommunication works.

P2C2.5i = Price payable per Km as adjusted in accordance with price variation Clause for size 2C x 2.5 sq mm signalling cable

P2C2.5o = Price per Km of cable as per purchase order/ Contract agreement.

S2C2.5 = Percentage of size 2C x 2.5 sq mm signalling cable shall govern the price adjustment of the contract price for signalling and telecommunication works.

P2C25i = Price payable per Km as adjusted in accordance with price variation Clause for size 2C x 25 sq mm signalling cable

P2C25o = Price per Km of cable as per purchase order/ Contract agreement.

S2C25 = Percentage of size 2C x 25 sq mm signalling cable shall govern the price adjustment of the contract price for signalling and telecommunication works.

PQCi = Price payable per Km as adjusted in accordance with price variation Clause for size 0.9mm dia, 6 Quad cable.

PQCo= Price per Km of cable as per purchase order/ Contract agreement.

QC = Percentage of size 0.9mm dia, 6 Quad cable shall govern the price.

LBo = The consumer price index for industrial workers – All India, published by Labour Bureau, Ministry of Labour, Government of India, (hereinafter called “CPI”) for the month of the Base Month;

LBi = The CPI for industrial workers – All India for the average price index of the 3 months of the quarter under consideration;

OFCo = The WPI for fibre cables for the month of the Base Month;

OFCi = The WPI for fibre cables for the average price index of the 3 months of the quarter under consideration;

OTHo = The WPI for all commodities for the month of the Base Month; and

OTHi = The WPI for all commodities for the average price index of the 3 months of the quarter under consideration.

3. The following percentages shall govern the price adjustment of the Contract Price for signalling and telecommunication works:

Works Component	Signalling			Telecommunication		
	Signalling Works	Signalling inventory	Integrated testing and Commissioning	Telecommunication Works	Telecomm inventory	Integrated testing and Commissioning
Electronics (PELEX)	****%	****%	-	****%	****%	-
Communication Equipment (PCEQP)	-	-	-	****%	****%	-
Optical Fibre Cable (POFC)	****%	-	-	****%	-	-
30C x 1.5 sq mm signalling cable(S30C)	****%	-	-	****%	-	-
24C x 1.5 sq mm signalling cable (S24C)	****%	-	-	****%	-	-
19Cx 1.5 sq mm signalling cable (S19C)	****%	-	-	****%	-	-
12C x 1.5 sq mm signalling cable (S12C)	****%	-	-	****%	-	-
9C x 1.5 sq mm signalling cable (S9C)	****%	-	-	****%	-	-
6C x 1.5 sq mm signalling cable (S6C)	****%	-	-	****%	-	-
4C x 1.5 sq mm signalling cable (S4C)	****%	-	-	****%	-	-
2C x 1.5 sq mm signalling cable (S2C)	****%	-	-	****%	-	-
12C x 2.5 sq mm signalling cable (S12C2.5)	****%	-	-	****%	-	-
2C x 2.5 sq mm signalling cable (S2C2.5)	****%	-	-	****%	-	-
2C x 25 sq mm signalling cable (S2C25)	****%	-	-	****%	-	-
0.9 mm dia, 6Quad cable (QC)	****%	-	-	****%	-	-
Labour (PLB)	****%	-	****%	****%	****%	****%
Other materials	****%	****%	****%	****%	****%	****%
Total	100%	100%	100%	100%	100%	100%

(Note- the percentages may be finalized by tendering authority depending on BOQ)

FORMULAE FOR SIGNALING & TELECOM CABLE

The price payable for signalling cables is variable as per Price Variation Formula given below:

For Signalling Copper Cables:

$$P_i = P_o + CuF (Cu - C_{uo}) + CCF_{cu}(CC - C_{Co}) + FeF (Fe - Fe_o)$$

For Telecom Copper Cables For Jelly Filled, 0.9 mm dia, 6 quad cable

$$P_i = P_o + CuF (Cu - C_{uo}) + AIF_{cu}(Al - A_{lo}) + CCF_{cu} (CC - C_{Co}) + FeF (Fe - Fe_o)$$

For Aluminium Power Cables:

$$P_i = P_o + AIF (Al - A_{lo}) + CCFAI(CC - C_{Co}) + FeF (Fe - Fe_o)$$

Where,

P_i = Price payable per KM as adjusted in accordance with Price variation clause.

P_o = Price per KM of cable as per Purchase order.

CuF = Variation factor for Copper

C_{uo} = Price of copper Rod in Rs. Per MT

$CCFCu$ = Variation factor for PVC Compound for Copper Signalling & Telecom cable

CCo = Price of PVC Compound in Rs. Per MT

AIF = Variation factor for Aluminium

A_{lo} = Price of EC grade LME Aluminium rods (Properzi rods) in Rs. Per MT.

$CCFAI$ = Variation factor for PVC Compound for Aluminium power cable

FeF = Variation factor for Steel

Fe_o = Price of Steel for Armour (Flat strip 4 mm. x 0.8mm/ Round 1.4mm dia) in Rs. Per MT

(Prices per MT for C_{uo} , CCo , Fe_o , A_{lo} as applicable on the 1st working day of the month, one month prior to the deadline for submission of bids. The above prices and indices are as published by IEEMA vide circular reference no. IEEMA (PVC) /CABLE --/-- one month prior to the deadline for submission of bids.)

Cu = Price of Copper Rod in Rs. Per MT.

CC = Price of PVC Compound in Rs. Per MT.

Fe = Price of Steel for Armouring (Flat strip 4mm x 0.8 mm/ Round 1.4mm dia) in Rs. Per MT.

Al = Price of EC grade LME Aluminium rods (Properzi rods) in Rs. Per MT.

(Prices per MT for Cu, CC, Fe, Al as prevailing on 1st working day of the calendar month covering the date One month prior to the date of inspection call letter will be applicable for the calculation of updated price. The above prices and indices are as published by IEEMA vide circular reference no. IEEMA (PVC) /CABLE --/--/-- one month prior to the date of inspection.)

The value of variation factors for copper, steel and PVC Compound are different for different sizes of signalling cables. Accordingly, the PVC formula for some of the types of signalling cable is as given under: -

Underground Railway Signalling Cable unscreened and armoured copper conductor

Size 30 C x 1.5 sq.mm. $P_{30Ci} = P_{30Co} + 0.391(Cu - Cu_o) + 0.557(CC - CC_o) + 0.425(Fe - Fe_o)$

For armouring, price of steel flat strip of size 4mmx0.8mm is to be taken into consideration.

Size 24C x 1.5 sq.mm

$P_{24Ci} = P_{24Co} + 0.313(Cu - Cu_o) + 0.481(CC - CC_o) + 0.398(Fe - Fe_o)$

For armouring, value of steel flat strip of size 4mmx0.8mm is to be taken into consideration.

Size 19C x 1.5 sq.mm

$P_{19Ci} = P_{19Co} + 0.248(Cu - Cu_o) + 0.395(CC - CC_o) + 0.343(Fe - Fe_o)$

For armouring, value of steel flat strip of size 4mmx0.8mm is to be taken into consideration.

Size 12C x 1.5 sq.mm

$P_{12Ci} = P_{12Co} + 0.157(Cu - Cu_o) + 0.277(CC - CC_o) + 0.289(Fe - Fe_o)$

Size 9C x 1.5 sq.mm

$P_{9Ci} = P_{9Co} + 0.117(Cu - Cu_o) + 0.241(CC - CC_o) + 0.383(Fe - Fe_o)$

For armouring, value of steel wire size 1.4mm dia is to be taken into consideration.

Size 6C x 1.5 sq.mm

$P_{6Ci} = P_{6Co} + 0.078(Cu - Cu_o) + 0.199(CC - CC_o) + 0.329(Fe - Fe_o)$

For armouring, value of steel wire size 1.4mm dia is to be taken into consideration.

	<p>Size 4Cx1.5 sq.mm</p> $P4Ci = P4Co + 0.052(Cu-Cuo) + 0.152(CC-CCo) + 0.277(Fe-Feo)$ <p>For armouring, value of steel wire size 1.4mm dia is to be taken into consideration.</p> <p>Size 2C x 4 sq.mm(multistrand)</p> $P2Ci = P2Co + 0.073(Cu-Cuo) + 0.156(CC-CCo) + 0.3(Fe-Feo)$ <p>For armouring, value of steel wire size 1.4mm dia is to be taken into consideration.</p> <p>Size 12C x 2.5 sq.mm</p> $P12C2.5i = P12C2.5o + 0.282(Cu-Cuo) + 0.371(CC-CCo) + 0.342(Fe-Feo)$ <p>For armouring, value of steel flat strip of size 4mmx0.8mm is to be taken into consideration.</p> <p>Size 2C x 2.5 sq.mm</p> $P2C2.5i = P2C2.5o + 0.047(Cu-Cuo) + 0.139(CC-CCo) + 0.277(Fe-Feo)$ <p>For armouring, value of steel wire size 1.4mm dia is to be taken into consideration.</p> <p>Size 2C x 25 sq.mm PVC insulated, armoured, Aluminium power cable</p> $P2C25i = P2C25o + 0.146(Al-Alo) + 0.303(CC-CCo) + 0.306(Fe-Feo)$ <p>For armouring, value of steel flat strip of size 4mmx0.8mm is to be taken into consideration.</p> <p>For Jelly filled, 0.9mm dia, 6 quad cable</p> $PQCi = PQCo + 0.135(Al-Alo) + 0.139(Cu-Cuo) + 0.515(CC-Cco) + 0.693(FeFeo).$ <p>For PVC Compound Grade CW-22, is to be taken into consideration.</p> <p>The demands for escalation of cost shall be allowed on the basis of provisional indices as mentioned above in table. Any adjustment needed to be done based on the finally published indices shall be made as and when they become available.</p> <p>Relevant city for referring "JPC (Joint Plant Committee)" rates of steel items (SQ /SB) in different Zonal Railways shall be as under :</p>
--	---

SL	City	Railway
1.	Delhi	Northern , North Central, North Eastern, North Western
2.	Kolkata	Eastern, East Central, East Coast, Northeast Frontier, South East Southeast Central
3.	Mumbai	Central, Western, West Central
4.	Chennai	Southern, South Central&South Western

Period of Work under consideration will mean as under:

- i. In the case of first Bill the period from the month of signing of agreement to the month of measurement of the first bill.
- ii. In the case of second and subsequent interim payment certificate and Final bills, the Period from the month of measurement for previous bill to the month of measurement of that bill.
- iii. As per provisions of contract (Clause 37.3/PCC) interim payments certificates are to be submitted by the contractor on monthly basis for the works/supply of items pertaining to a particular month. However, in case a bill is submitted for a period pertaining to more than a calendar month the average indices for those months and previous month(s) shall be used for calculation purpose.

Responsibility of arranging the RBI indices /Economic advisor indices/Labour Bulletins desired by the Employer or the Engineer shall rest with the Contractor.

- (B) Procedure in case of Delay in Availability of Final RBI Indices/ Economic advisor indices**
Where the final Price Indices are not available in the Economic advisor, while making payment towards interim payment certificate, payment towards Price Variation will be made on provisional basis based on the indices available, to be adjusted in subsequent bills as and when the final Indices figures become available.

(C) Adjustment on Account of Price Variation

Adjustment on account of Price Variations may be positive (in which case extra amount shall be paid to the Contractor), or negative (in which case the amount of Price Variation shall be recovered from the Contractor). Adjustment on account of Price Variation shall be calculated separately, for each period, between two successive dates of measurements for bills and paid along with each bill as claimed by the contractor.

After verifying the bill, the Engineer shall certify the adjustment amount and advise the same to the Employer along with the interim payment certificate. Should any extra amount be due to Contractor, the Employer shall pay the same. Any amount due from Contractor on account of negative adjustment shall be recovered from his pending or other bills at the earliest.

The above adjustment on account of Price Variation payment shall be made to the contractor in accordance with the proportion stipulated in Schedule of Payment Currencies by using exchange rate on the last day of the period to which a particular interim payment certificate is related as per the website of Reserve Bank of India (RBI). In case the exchange rate on the above date, is not available in this web site, it will be as per the web site of Financial Benchmark India Private Limited (FBIL) as recommended by RBI.

In case the exchange rate of particular currency is not available on the above date in both these websites then the exchange rate as per the website of the Central Bank of

	<p>that country to which this currency belongs will be adopted. In case the exchange rate of that currency is not directly available in INR on that website then the currency will be first converted to USD as per the exchange rate between that foreign currency and US Dollar on that web site and then converted from USD to INR as per RBI or FBIL exchange rate between US Dollar and INR, as prevailing on the said date.</p> <p>(D) Limit of Price Adjustment Provided that, in determining all such price adjustment in accordance with the aforesaid Sub-Clauses:</p> <p>a. No account will be taken of any amount by which any cost incurred by the Contractor has been increased by default or negligence of the Contractor.-p</p> <p>b. If the Contractor fails to complete the work within time for completion prescribed under Clause 26.4 the adjustment of prices thereafter until the completion of the works shall be made using either the indices or prices, whichever is more favourable to the Employer, provided that if an extension of time is granted pursuant to Sub-Clause 26.5/PCC, the above position shall apply to the adjustments made after expiry of such extension of time.</p> <p>(E) Price Variation during extended period of completion The price adjustment as worked out above i.e., either increase or decrease will be applicable up to the stipulated Completion Date of the Works, including the extended period of completion where such extension has been granted under Sub-Clause 26.5/PCC and where such an extension has been granted, the price adjustment will be due as follows:</p> <p>a. In a. In case the indices increase above the indices applicable to a bill made on the last date of original completion period or the extended period under Sub-Clause 26.5/PCC, the price adjustment for the period of extension granted in accordance with Sub-Clause 26.5/PCC will be limited to the amount payable as per the indices applicable to a statement made on the last date of the original completion period or the extended period as the case may be.</p> <p>b. In case the indices fall below the indices applicable to a statement made on the last date of the original or extended period of completion, then the lower indices will be adopted for Price Adjustment for the period of extension</p>
<p>New Clause-1.1</p>	<p>Assignment</p> <p>Neither Party shall assign the whole or any part of the Contract or any benefit or interest in or under the Contract. However, either Party:</p> <p>i. may assign the whole or any part with the prior agreement of the other Party, at the sole discretion of such other Party, and</p> <p>ii. may, as security in favour of a bank or financial institution, assign its right to any moneys due, or to become due, under the Contract.</p>
<p>New Clause -1.2</p>	<p>Care and Supply of Documents</p> <p>The Specification and Drawings shall be in the custody and care of the Employer. Unless otherwise stated in the Contract, two copies of the Contract and of each subsequent Drawing</p>

	<p>shall be supplied to the Contractor, who may make or request further copies at the cost of the Contractor.</p> <p>Each of the Contractor's Documents shall be in the custody and care of the Contractor, unless and until taken over by the Employer. Unless otherwise stated in the Contract, the Contractor shall supply to the Engineer six copies of each of the Contractor's Documents.</p> <p>The Contractor shall keep, on the Site, a copy of the Contract, publications named in the Specification, the Contractor's Documents (if any), the Drawings and Variations and other communications given under the Contract. The Employer's Personnel shall have the right of access to all these documents at all reasonable times.</p> <p>If a Party becomes aware of an error or defect in a document which was prepared for use in executing the Works, the Party shall promptly give notice to the other Party of such error or defect.</p>
<p>New Clause-1.3</p>	<p>Delayed Drawings or Instructions</p> <p>The Contractor shall give notice to the Engineer whenever the Works are likely to be delayed or disrupted if any necessary drawing or instruction is not issued to the Contractor within a particular time, which shall be reasonable. The notice shall include details of the necessary drawing or instruction, details of why and by when it should be issued, and details of the nature and amount of the delay or disruption likely to be suffered if it is late. If the Contractor suffers delay and/or incurs Cost as a result of a failure of the Engineer to issue the notified drawing or instruction within a time which is reasonable and is specified in the notice with supporting details, the Contractor shall give a further notice to the Engineer and shall be entitled subject to Clause 4.1/SCC of contract conditions [Contractor's Claims] to:</p> <ul style="list-style-type: none"> (a) an extension of time for any such delay, if completion is or will be delayed, under Sub-Clause 26.5/PCC [Extension of Time for Completion], and (b) payment of any such Cost, which shall be included in the Contract Price. <p>After receiving this further notice, the Engineer shall proceed in accordance with New-Clause 3.5/PCC [Determinations] to agree or determine these matters.</p> <p>However, if and to the extent that the Engineer's failure was caused by any error or delay by the Contractor, including an error in, or delay in the submission of, any of the Contractor's Documents, the Contractor shall not be entitled to such extension of time, Cost or profit.</p>
<p>New Clause-1.4</p>	<p>Employer's Use of Contractor's Documents</p> <p>As between the Parties, the Contractor shall retain the copyright and other intellectual property rights in the Contractor's Documents and other design documents made by (or on behalf of) the Contractor.</p> <p>The Contractor shall be deemed (by signing the Contract) to give to the Employer a non-terminable transferable non-exclusive royalty-free licence to copy, use and communicate the Contractor's Documents, including making and using modifications of them. This licence shall:</p> <ul style="list-style-type: none"> (a) apply throughout the actual or intended working life (whichever is longer) of the relevant parts of the Works,

	<p>(b) entitle any person in proper possession of the relevant part of the Works to copy, use and communicate the Contractor's Documents for the purposes of completing, operating, maintaining, altering, adjusting, repairing and demolishing the Works, and</p> <p>(c) in the case of Contractor's Documents which are in the form of computer programs and other software, permit their use on any computer on the Site and other places as envisaged by the Contract, including replacements of any computers supplied by the Contractor.</p> <p>The Contractor's Documents and other design documents made by (or on behalf of) the Contractor shall not, without the Contractor's consent, be used, copied or communicated to a third party by (or on behalf of) the Employer for purposes other than those permitted under this Sub-Clause.</p>
New Clause-1.5	<p>Contractor's Use of Employer's Documents</p> <p>As between the Parties, the Employer shall retain the copyright and other intellectual property rights in the Specification, the Drawings and other documents made by (or on behalf of) the Employer. The Contractor may, at his cost, copy, use, and obtain communication of these documents for the purposes of the Contract. They shall not, without the Employer's consent, be copied, used or communicated to a third party by the Contractor, except as necessary for the purposes of the Contract.</p>
New Clause-1.6	<p>Confidential Details</p> <p>The Contractor shall disclose all such confidential and other information as the Engineer may reasonably require in order to verify the Contractor's compliance with the Contract.</p> <p>The Contractor shall treat the details of the Contract as private and confidential, except to the extent necessary to carry out the Contractor's obligations under the Contract or to comply with applicable Laws. The Contractor shall not publish or disclose any particulars of the Works without the previous agreement of the Employer. However, the Contractor shall be permitted to disclose any publicly available information, or information otherwise required to establish his qualifications to compete for other projects.</p>
New Clause-1.7	<p>Compliance with Laws</p> <p>The Contractor shall, in performing the Contract, comply with applicable Laws. Unless otherwise stated in the Special Conditions of Contract:</p> <p>(a) the Employer shall have obtained (or shall obtain) the planning, zoning or similar permission for the Permanent Works, and any other permissions described in the Specification as having been (or being) obtained by the Employer; and the Employer shall indemnify and hold the Contractor harmless against and from the consequences of any failure to do so; and</p> <p>(b) the Contractor shall give all notices, pay all taxes, duties and fees, and obtain all permits, licences and approvals, as required by the Laws in relation to the execution and completion of the Works and the remedying of any defects; and the Contractor shall indemnify and hold the Employer harmless against and from the consequences of any failure to do so.</p>
New Clause-1.8	<p>Joint Venture - Joint and Several Liability</p> <p>If the Contractor constitutes (under applicable Laws) a Joint Venture of two or more persons/firms:</p> <p>(a) these persons shall be deemed to be jointly and severally liable to the Employer for the performance of the Contract;</p>

	<p>(b) these persons shall notify the Employer of their leader who shall have authority to bind the Contractor and each of these persons; and</p> <p>(c) the Contractor shall not alter its composition or legal status without the prior consent of the Employer.</p> <p>(d) In the event of default by any partner of Joint Venture, on or after achieving 25% of the financial progress (excluding advance if any) the lead partner or remaining partner(s), in case the defaulting partner is the lead partner, shall notify the Employer within twenty eight (28) days of the occurrence and within Fifty six (56) days of the said notification, the lead partner or remaining partner(s), who are not the defaulting partner, shall assign the works of the defaulting partner, to equally competent party with prior consent of the Employer. For this purpose the term “equally competent party” shall mean as under:</p> <p>“The new JV partner replacing the defaulting partner should meet the EQC requirement of package/combination of packages which was met by the defaulting partner on the basis of which the original tender was awarded.”</p> <p>The replacement of any defaulting partner, with the new partner shall be subject to the condition that the new partner has to submit additional performance security equal to 10% of balance cost of work of the JV partner being replaced. The performance security submitted by the defaulting partner shall also continue with K-RIDE till satisfactory completion of the work.</p> <p>(e) Notwithstanding the consent of the Employer for change in composition or legal status of the Joint Venture the partners shall continue to be jointly and severally liable to the Employer.</p> <p>(f) The Joint Venture shall enter into a Joint Venture Agreement incorporating the provisions of sub-paras (a) to (e) based upon the form annexed to the Conditions of Contract. The JV agreement shall indicate precisely the specific role of all members of the JV in respect of planning, design, construction equipment, key personnel, work execution, and financing of the project. The authority to sign the JV Agreement shall be evidenced by approved legal instruments.</p> <p>Notwithstanding the contents of the sub-clauses above, if the performance of any JV partner is not found satisfactory by the Employer, in respect of the responsibilities assigned to him as per JV agreement which is a part of this agreement, the Employer may issue notice of such default to the said JV partner or the JV (depending upon reasons of default) and declare the said JV partner or the JV as Poor Performer. The issue of such notice shall automatically debar the JV partner or JV as the case may be from participating in any K-RIDE tender from the date of issue of notice of default.</p>
<p>New Clause-1.9</p>	<p>Inspections by the Employer</p> <p>The Contractor shall permit the Employer and/or persons appointed by the Employer to inspect the Site and/or the Contractor’s records relating to the performance of the Contract.</p>
<p>New Clause-1.10</p>	<p>Bidder’s Credentials:</p> <p>The bidder shall submit an affidavit on a stamp paper to the effect that all the documents submitted by her along with her bid are true. This shall be mandatory all bids. The bid shall be summarily rejected if the bidder fails to submit this undertaking along with the bid.</p>

	<p>After opening the financial bid, the tender committee shall verify the credentials of the bidder who is declared as the lowest bidder (L1) for their authenticity. In case the credentials of L1 are not found to be in order, The bid shall be treated as technically unresponsive and thus invalid. The process shall be repeated for the next higher bidder till the valid L1 is established. If any document (or copy thereof) submitted by a bidder is found to be false/forged:</p> <ul style="list-style-type: none"> a) The bidder/each partner/member of the bidding firm shall be liable to legal actions apart from punitive actions, as decided by competent authority of K-RIDE. In such an eventuality. The bid shall also be summarily rejected. b) If the contract has already been awarded, or Letter of Acceptance (LoA) has been issued and in the event of any failure to comply with the above, the contract shall be terminated, irrespective of the stage of progress in execution of the work. In such an eventuality, Security Deposit (SD), performance Guarantee (PG) and partial/full payments otherwise due to the contractor, in respect of the partial/full work executed by the contractor, shall be forfeited by the K-RIDE. c) Other punitive actions, like banning the bidder and partners/members of the bidding firm for future dealings with K-RIDE/Government of India/ Government of Karnataka may also be taken.
	<p>2. THE EMPLOYER</p>
<p>New Clause-2.1</p>	<p>Permits, Licenses or Approvals</p> <p>The Employer shall (where he is in a position to do so) provide reasonable assistance to the Contractor at the request of the Contractor:</p> <ul style="list-style-type: none"> (a) by obtaining copies of the Laws of the Country which are relevant to the Contract but are not readily available, and (b) for the Contractor's applications for any permits, licences or approvals required by the Laws of the Country: <ul style="list-style-type: none"> (i) which the Contractor is required to obtain under New-Clause 1.7/PCC [Compliance with Laws], (ii) for the delivery of Goods, including clearance through customs, and (iii) for the export of Contractor's Equipment when it is removed from the Site.
<p>New Clause -2.2</p>	<p>Employer's Personnel</p> <p>The Employer shall be responsible for ensuring that the Employer's Personnel and the Employer's other contractors on the Site:</p> <ul style="list-style-type: none"> (a) co-operate with the Contractor's efforts under New-Clause 4.24/PCC [Co-operation], and (b) take actions similar to those which the Contractor is required to take under sub-paragraphs (a), (b) and (c) of New-Clause 4.26/PCC [Safety Procedures] and under New-Clause 4.36/PCC [Protection of the Environment].
<p>New Clause-2.3</p>	<p>Employer's Financial Arrangements</p> <p>The Employer has sourced the funds to finance the project</p> <p>Assignment by the Employer</p> <p>The Employer shall be fully entitled without the consent of the Contractor, to assign the benefit of the Contract or any part thereof and any interest therein or there under to any third party.</p>

<p>New Clause-2.4</p>	<p>Employer's Claims</p> <p>If the Employer considers himself to be entitled to any payment under any Clause of these Conditions or otherwise in connection with the Contract, and/or to any extension of the Defects Notification Period, the Employer or the Engineer shall give notice and particulars to the Contractor. However, notice is not required for payments due under New-Clause 4.37/PCC [Electricity, Water and Gas], under New-Clause 4.38/PCC [Employer's Equipment and Free-Issue Material], or for other services requested by the Contractor.</p> <p>The notice shall be given as soon as practicable after the Employer became aware, or should have become aware, of the event or circumstances giving rise to the claim. A notice relating to any extension of the Defects Notification Period shall be given before the expiry of such period.</p> <p>The particulars shall specify the Clause or other basis of the claim, and shall include substantiation of the amount and/or extension to which the Employer considers himself to be entitled in connection with the Contract. The Engineer shall then proceed in accordance with New-Clause 3.5/PCC [Determinations] to agree or determine (i) the amount (if any) which the Employer is entitled to be paid by the Contractor, and/or (ii) the extension (if any) of the Defects Notification Period in accordance with New-Clause 6.3/PCC [Extension of Defects Notification Period].</p> <p>This amount may be included as a deduction in the Contract Price and Payment Certificates. The Employer shall only be entitled to set off against or make any deduction from an amount certified in a Payment Certificate, or to otherwise claim against the Contractor, in accordance with this Sub-Clause.</p>
	<p>3.THE ENGINEER</p>
<p>New Clause-3.1</p>	<p>Engineer's Duties and Authority</p> <p>The Employer shall appoint the Engineer who shall carry out the duties assigned to him in the Contract. The Engineer's staff shall include suitably qualified engineers and other professionals who are competent to carry out these duties.</p> <p>The Engineer shall have no authority to amend the Contract.</p> <p>The Engineer may exercise the authority attributable to the Engineer as specified in or necessarily to be implied from the Contract.</p> <p>However, the Engineer shall obtain the specific approval of the Employer before taking action under the following Sub-Clauses of these Conditions:</p> <ol style="list-style-type: none"> a) New-Clause 4.30/PCC [Unforeseeable Physical Conditions] Agreeing or determining an extension of time and/or additional cost. b) Sub-Clause 26.5/PCC [Extension of Time for Completion] Agreeing or determining extension of time. c) New-Clause 6.9/PCC [Performance Certificate] Issue of Performance Certificate. d) Sub-Clause 34. Except, <ol style="list-style-type: none"> i) in an emergency situation as determined by the Engineer and as amplified in sub-paras (h) and (i) below, or ii) DELETED

	<p>e) Sub-Clause 34.3 -Variation Procedure: Approving a proposal for Variation submitted by the Contractor in accordance with Sub Clause 34.1 or 34.2.</p> <p>f) Sub-Clause 34.4 -Payment in applicable Currencies: Specifying the amount payable in each of the applicable currencies for a Variation.</p> <p>g) Clause 4.1/SCC: Contractor Claims for extension of time and/or additional payment.</p> <p>h) DELETED</p> <p>i) DELETED</p> <p>Notwithstanding the obligation, as set out above, to obtain approval, if, in the opinion of the Engineer, an emergency occurs affecting the safety of life or of the Works or of adjoining property, he may, without relieving the Contractor of any of his duties and responsibility under the Contract, instruct the Contractor to execute all such work or to do all such things as may, in the opinion of the Engineer, be necessary to abate or reduce the risk. The Contractor shall forthwith comply, despite the absence of approval of the Employer, with any such instruction of the Engineer. The Engineer shall determine an addition to the Contract Price, in respect of such instruction, in accordance with Clause 34/PCC and shall notify the Contractor accordingly, with a copy to the Employer.</p> <p>i) In case the emergency mentioned in above Sub-paras occurs on account of failure of Contractor, by way of not adhering to the approved scheme of work or not taking adequate safety precautions or by any other reason attributable to the contractor, then no additional amounts shall be paid to the Contractor for attending to such emergencies and the Contractor shall be liable for Employer's claims.</p> <p>j) Clause 7/PCC regarding deployment of Sub-Contractors.</p>
<p>New Clause-3.2</p>	<p>Delegation by the Engineer</p> <p>The Engineer may from time to time assign duties and delegate authority to assistants, and may also revoke such assignment or delegation. These assistants may include a resident engineer, and/or independent inspectors appointed to inspect and/or test items of Plant and/or Materials. The assignment, delegation or revocation shall be in writing and shall not take effect until copies have been received by both Parties.</p> <p>However, unless otherwise agreed by both Parties, the Engineer shall not delegate the authority to determine any matter in accordance with New-Clause 3.5/PCC [Determinations].</p> <p>Assistants shall be suitably qualified persons, who are competent to carry out these duties and exercise this authority, and who are fluent in the language for communications defined in Sub-Clause 3/CC [Law and Language].</p> <p>Each assistant, to whom duties have been assigned or authority has been delegated, shall only be authorised to issue instructions to the Contractor to the extent defined by the delegation. Any approval, check, certificate, consent, examination, inspection, instruction, notice, proposal, request, test, or similar act by an assistant, in accordance with the delegation, shall have the same effect as though the act had been an act of the Engineer. However:</p> <p>(a) any failure to disapprove any work, Plant or Materials shall not constitute approval, and shall therefore not prejudice the right of the Engineer to reject the work, Plant or Materials;</p> <p>(b) if the Contractor questions any determination or instruction of an assistant, the Contractor may refer the matter to the Engineer, who shall promptly confirm, reverse or vary the determination or instruction.</p>

New Clause-3.3	<p>Instructions of the Engineer</p> <p>The Engineer may issue to the Contractor (at any time) instructions and additional or modified Drawings which may be necessary for the execution of the Works and the remedying of any defects, all in accordance with the Contract. The Contractor shall only take instructions from the Engineer, or from an assistant to whom the appropriate authority has been delegated under this Clause. If an instruction constitutes a Variation, Clause34/PCC [Variations and Adjustments] shall apply.</p> <p>The Contractor shall comply with the instructions given by the Engineer or delegated assistant, on any matter related to the Contract. Whenever practicable, their instructions shall be given in writing. If the Engineer or a delegated assistant,</p> <ul style="list-style-type: none"> (a) gives an oral instruction and (b) receives a written confirmation of the instruction, from (or on behalf of) the Contractor, within two working days after giving the instruction, and (c) does not reply by issuing a written rejection and/or instruction within two working days after receiving the confirmation, (d) then the confirmation shall constitute the written instruction of the Engineer or delegated assistant (as the case may be).
New Clause-3.4	<p>Replacement of the Engineer</p> <p>Notwithstanding New-Clause 3.1/PCC, if the Employer intends to replace the Engineer, the Employer shall, not less than 21 days before the intended date of replacement, give notice to the Contractor of the name, address and relevant experience of the replacement Engineer.</p>
New Clause-3.5	<p>Determinations</p> <p>Whenever these Conditions provide that the Engineer shall proceed in accordance with this New-Clause 3.5/PCC to agree or determine any matter, the Engineer shall consult with each Party in an endeavour to reach agreement. If agreement is not achieved, the Engineer shall make a fair determination in accordance with the Contract, taking due regard of all relevant circumstances.</p> <p>The Engineer shall give notice to both Parties of each agreement or determination, with supporting particulars. Each Party shall give effect to each agreement or determination unless and until revised under Clause 4/SCC [Claims, Disputes and Arbitration].</p>
4.THE CONTRACTOR	
New Clause-4.1	<p>Contractor's General Obligations</p> <p>The Contractor shall design (to the extent specified in the Contract), execute and complete the Works in accordance with the Contract and with the Engineer's instructions, and shall remedy any defects in the Works.</p> <p>The Contractor shall provide the Plant and Contractor's Documents specified in the Contract, and all Contractor's Personnel, Goods, consumables and other things and services, whether of</p>

	<p>a temporary or permanent nature, required in and for this design, execution, completion and remedying of defects.</p> <p>All equipment, and material, to be incorporated in or required for the Works shall be procured from approved sources as stipulated in the Contract.</p> <ul style="list-style-type: none"> i. All plants / equipment to be deployed on the work shall carry designated authority certificate. Where not specified, it shall have third party safety certificate for the safe working of the equipment and shall be renewed after every 3 months. This certificate shall be produced to the Engineer as and when required. ii. All the construction plant shall be provided with the experienced operators having valid license issued by the competent authority. iii. Any material or equipment not meeting the approval of the Engineer shall be removed from the site immediately. iv. All Contractor's Equipment and Temporary Works provided by the Contractor shall, when brought on to the site, be deemed to be exclusively intended for execution of the Works and not be removed without the consent in writing of the Engineer. Such consent shall not be unreasonably withheld or delayed. <p>The Contractor shall be responsible for the adequacy, stability and safety of all Site operations and of all methods of construction. Except to the extent specified in the Contract, the Contractor (i) shall be responsible for all Contractors' Documents, Temporary Works, and such design of each item of Plant and Materials as is required for the item to be in accordance with the Contract, and (ii) shall not otherwise be responsible for the design or specification of the Permanent Works.</p> <p>The Contractor shall throughout the execution of the Works including the carrying out of any testing, commissioning or remedying of any defect:</p> <ul style="list-style-type: none"> i. provides and maintain all lights, guards, fences and warning signs and watchmen when and where necessary or required by the Engineer or by laws or by any relevant authority for the protection of the Works and for the safety and convenience of the public and all persons on or in the vicinity of the Site; and ii. Contractor is required to take note of all the necessary provisions in Employer's Safety, Health and Environment Manual (SHE Manual) and the Contractor's price shall be inclusive of all the necessary costs to meet the prescribed safety standards as specified in the Special Conditions of Contract. In the case, the Contractor fails in the above; the Employer may provide the necessary arrangements and recover the costs from the Contractor
<p>New Clause-4.2</p>	<p>Tools, Plants and Equipment Supplied by the Employer</p> <ul style="list-style-type: none"> i. Except for any specific item mentioned in the Special Conditions of Contract or in Employer's Requirements, the Contractor shall provide all tools, plants and Equipment for the Works. In respect of such exceptional tools, plants or Equipment committed to be provided by the Employer under terms and conditions specified in the Special Conditions of Contract, the Contractor shall take all reasonable care and shall be responsible for all damages or loss caused by him, his representatives, sub-contractors or his workmen or others while they are in his charge.

	<ul style="list-style-type: none"> ii. No tools, plant and equipment shall be supplied by the Employer. Unless specifically incorporated in special conditions, the Contractor has to arrange all tools, plant, equipment required for the work. iii. On completion of the Works, the Contractor shall hand over the unused balance of the tools, plants and Equipment supplied by the Employer to the Employer back in good order and repair, fair wear and tear expected, and shall be responsible for any failure to account for the same or any damage done thereto. iv. The decision of the Engineer as to the amount recoverable from the Contractor on this account shall be final and binding.
New Clause-4.3	<p>Employer's Materials</p> <p>Except for items mentioned in the Special Conditions of Contract, the Contractor shall provide all materials for the Works. Material if any, to be provided by Employer will be done only in a phased manner as per pre-approved program, against a Bank Guarantee for the value of the Material and at terms and conditions for issue, upkeep, usage, return and recovery of such Materials as specified in Special Conditions of Contract.</p>
New Clause-4.4	<p>Sheds, Stores, Yards</p> <p>It shall be the responsibility of the Contractor to provide at his own expense the required sheds, store houses, and yards for both Permanent and Temporary Works and provide free access to the Engineer and the Engineer's Representative who will have right of inspection including that of instructing the Contractor to remove a particular material from the stores and not to use the same on the Works.</p>
New Clause-4.5	<p>Temporary Works</p> <p>The Contractor's proposals for erection of all ancillary and temporary works shall be in conformity with the proposals submitted along with the Tender and modifications thereto as approved by Engineer.</p> <p>The Contractor shall submit drawings, supporting design calculations of Temporary works, where called for by the Engineer and other relevant details of all such works to the Engineer for approval at least one month before he desires to commence such works. Approval by the Engineer of any such proposal shall not relieve the Contractor of his responsibility for sufficiency of such works.</p> <p>All temporary works necessary for the proper execution of the Works shall be provided and maintained by the Contractor at his cost (unless otherwise provided in tender document) and subject to the consent of the Engineer shall be removed by Contractor at his own expense when they are no longer required and in such manner as the Engineer shall direct. In case the Contractor fails to remove the temporary works on completion the Engineer is authorized to get the same removed and recover the cost thereof from the Contractor.</p>
New Clause-4.6	<p>Access for Engineer</p> <p>The Contractor shall allow at all times the Engineer or the Engineer's assistant or any other person authorised by the Engineer access to the Site and to any place where work in connection with the Contract is being carried out or is intended to be carried out and to any place where materials or plant are being manufactured, fabricated and/or assembled for the Works. The Contractor shall ensure that sub contracts if any shall contain provisions entitling the Engineer or any person authorised by him to have such access.</p>
New Clause-4.7	<p>Access Road and Way Leave</p> <ul style="list-style-type: none"> I. Providing access roads/ way leaves to the site will be Contractor's responsibility. II. The Contractor shall pay the statutory vehicle license and permit fees for use of public roads. The Contractor's heavy construction or tracked equipment shall not travel on any

	<p>public road or bridge, unless the Contractor has made arrangements with the authority concerned and has obtained the approval of the Engineer to such arrangements.</p> <p>III. The Contractor shall repair any damage to the road or bear the cost thereof due to movement of contractor's plants and equipment, vehicles etc. to the specifications and satisfaction of road authorities as well as of Engineer.</p> <p>IV. The Contractor shall plan transportation of construction materials to work site in accordance with traffic regulations enforced by local traffic authorities from time to time and in such a way that congestion on the roads and road accidents are avoided. The Contractor should study this aspect thoroughly before quoting for the work.</p>
<p>New Clause-4.8</p>	<p>Contractor to keep Site Clear</p> <p>i. During the execution of the Works, the Contractor shall keep the Site free from all unnecessary obstruction, and shall store or dispose of any Contractor's Equipment or surplus materials. The Contractor shall clear away and remove from the Site any wreckage, rubbish or Temporary Works no longer required.</p> <p>ii. On completion of the works, the Contractor shall clear away and remove from site all Constructional Plant, surplus material and Temporary Works. He should leave the whole of the site and Works in a clean, tidy and workman like condition to the satisfaction of the Engineer.</p> <p>iii. On completion of Work the Contractor shall also clear away the labour camps, hutments and other related installations and restore the land to its original condition to the satisfaction of the Engineer within 45 days of the physical completion of Work. The cost on account of delay in return of land and reinstatement of original condition within the stipulated time as determined by Engineer will be recovered from the Contractor's dues.</p> <p>iv. All garbage shall be removed from site daily or as they accumulate. All surface and sub-soil drains shall be maintained in a clean, sound and satisfactory state of performance. No extra payment shall be made on this account.</p> <p>v. No final payment in settlement of the accounts for Works shall be made till, in addition to any other condition necessary for such final payment, site clearance and clearances of labour camps etc. shall have been effected by him. Such clearance may be made by the Engineer through any other agency at the expense of the Contractor in the event of the Contractor's failure to comply with this provision within 7 days after receiving notice to that effect from the Engineer. All expenses on such removal / clearance shall be debit able to the Contractor as loans due from the Contractor to the Employer, and the Employer shall be competent to recover the same from Contractor's on-account or final bills, or from Performance Security amount or from any other amount payable to the Contractor in any other Contract.</p>
<p>New Clause-4.9</p>	<p>Security of the Site</p> <p>I. The Contractor shall take all measures necessary to ensure security, including exercising control over all persons and vehicles which are employed or engaged on the Site or in connection with the Works or the other works comprising the Project and with the security arrangements applicable to any other site within the Project.</p> <p>II. The Contractor shall arrange the issue of passes for the admission of all persons and vehicles to the Site or to any part thereof and may refuse admission to or remove from the Site any person or vehicle failing to show an appropriate pass on demand to any duly authorized person.</p>

	<p>III. If required by the Engineer, the Contractor shall submit a list identifying all persons to whom passes have been issued together with two photographs of each person and all entities to which a pass has been issued in respect of any vehicle and shall satisfy the Engineer of the bonafides of any such person or entity.</p> <p>IV. The Contractor shall not, without the written permission of the Engineer or otherwise in accordance with the Contract, allow access to the Site to any person unless the presence on Site of such person is necessary in connection with the execution of the Works or with the discharge of the duties of any relevant authority.</p> <p>V. The Contractor shall be wholly responsible for security of site and Works. The Contractor shall follow relevant Safety and Security instructions issued by the concerned Authorities from time to time and shall work in close coordination with the concerned Authorities.</p>
New Clause-4.10	<p>Contractor's Operations on Site</p> <p>I. The Contractor shall confine his operations to the Site, and to any additional area which may be provided to the Contractor and agreed by the Engineer as working areas. The Contractor shall take all necessary precautions to keep his personnel and equipment within the Site and such additional areas, and to keep and prohibit them from encroaching on adjacent land.</p> <p>II. The Contractor, after obtaining any necessary consent from any relevant authority, shall submit to the Engineer proposals showing the layout of pedestrian routes, lighting, signs, and guarding any road opening or traffic diversion which may be required in connection with the execution of the Works and which the Contractor intends to construct. Any consent given by the Engineer to such proposals shall not relieve the Contractor of any obligation under the Contract or absolve the Contractor from any liability for or arising from such proposals or the implementation thereof.</p> <p>III. All lights provided by the Contractor shall be so placed or screened as not to interfere with signs, signals or lights. The Contractor shall not in any way obscure or affect signs, signals or lights, in use by any relevant authority. In the event that the Contractor does so, the Contractor shall pay all costs associated with the re-fitting, re-instating or provision of alternatives for any sign, signal or light, obscured or affected.</p> <p>IV. For the purposes of this Clause only, "Site" shall include off-Site places of manufacture or storage and the Contractor's Work Areas and shall include, areas provided to the Contractor by others.</p>
New Clause-4.11	<p>Publicity</p> <p>The Contractor shall not publish or otherwise circulate alone or in conjunction with any other person, any articles, photographs or other materials relating to the Contract, the Site, the Works, the Project or any part thereof, nor impart to the press, or any radio or television network any information relating thereto, nor allow any representative of the media access to the Site, Contractor's Works Areas, or off-Site place of manufacture, or storage except with the permission, in writing, of the Employer. The Contractor shall ensure that his sub-contractors of any tier shall be bound by a like obligation and shall, if so required by the Employer, enforce the same at his own expense. The provisions of this Sub-Clause shall not exempt the Contractor</p>

	from complying with any statutory provision in regard to the taking and publication of photographs.
New Clause-4.12	<p>Disclosure of Relationship</p> <p>If the Contractor or any partner of the Contractor or Director of the Contractor's company is closely related to any of the Officers of the Employer or the Engineer, or alternatively, if any close relative of an officer of the Employer or the Engineer has financial interest / stake in the Contractor's firm, the same shall be disclosed by the Contractor at the time of filing his tender. Any failure to disclose the interest involved, shall entitle the Employer to rescind the Contract, without payment of any compensation to the Contractor. The Contractor shall note that he is prohibited from developing such interest during the Contract period.</p>
New Clause-4.13	<p>Use Of Explosives</p> <p>Explosives if required on the Work shall be used by Contractor only with prior Approval of the Engineer and in the manner and to the extent permitted by him. The explosives shall be handled, stored in a special magazine to be provided at the cost of the Contractor and used under the strict supervision of persons licensed for this purpose under the requisite statutory rules and regulations. The Contractor shall take all precautions in transporting and using the explosives and avoid damage to nearby structures and utilities. The Contractor shall be responsible for taking all the precautions in the usage of the explosives at Contractor's cost, sole risk and responsibility. The Contractor shall hold the Employer harmless and indemnify for the above.</p>
New Clause-4.14	<p>In pursuance with this policy, the Employer</p> <p>a. Will reject the Tender for the Work or rescind the Contract, if the Employer determines that the Tenderer/Contractor has engaged in corrupt or fraudulent practices.</p> <p>b. Will declare a Tenderer/Contractor ineligible, either indefinitely or for a minimum period of 2 years from the date of identification of such prohibited conduct, to be awarded a Contract/s if the Employer at any time determines that the Contractor has engaged in corrupt or fraudulent practices in competing for, or in executing the Contract.</p>
New Clause-4.15	<p>Compensation to Contractor on rescission of Contract under this clause</p> <p>In the event of rescission of Contract, the Contractor shall not be entitled to any compensation whatsoever, except for the work done up to the date of rescission.</p>
New Clause-4.16	<p>Quality Assurance</p> <p>Unless otherwise stated in Special Conditions of Contract and/or Employer's Requirement, the Contractor shall institute a quality assurance system to demonstrate compliance with the requirements of the Contract. Such system shall be in accordance with the details stated in the Contract. Compliance with the quality assurance system shall not relieve the Contractor of his duties, obligations or responsibilities.</p> <p>Details of all procedure and compliance documents shall be submitted to the Engineer for his consent before each execution stage is commenced</p>
New Clause-4.17	<p>Work by Persons Other than Contactor</p> <p>I. If the Contractor shall fail to carry out any work required under the Contract or refuse to comply with any instruction or order given by the Engineer in accordance with the Contract within a reasonable time, the Engineer may give the Contractor 14 days' notice in writing to carry out such work or comply with such instruction.</p> <p>II. If the Contractor fails to comply with such notice, the Employer shall be entitled to carry out such work or instruction by his own workmen or by other contractors in whatever manner the Engineer decides, be it single Tender or limited Tender or open Tender or on entrustment basis without any right of appeal by the contractor.</p> <p>III. However, in case of emergencies/urgencies/affecting safety the period of 14 days' notice shall be 24hours notice in writing. The Classification of work as</p>

	<p>emergencies/urgencies/affecting safety is the prerogative of Engineer and his decision is final and binding on the contractor. Without prejudice to any other right or remedy, all additional expenditure properly incurred by the Employer in having such work or instruction carried out shall be recoverable by the Employer from the Contractor.</p> <p>IV. If by reason of any accident or failure or other event occurring to, in, or in connection with the Works any remedial or other work shall, in the opinion of the Engineer, be urgently necessary and the Contractor is unable or unwilling at once to do such remedial or other work, the Engineer may authorize the carrying out of such remedial or other work by a person other than the Contractor.</p> <p>V. If the remedial or other work so authorized by the Engineer is work, which, in the Engineer's opinion, the Contractor was liable to do under the Contract; all expenses properly incurred in carrying out the same shall be recoverable by the Employer from the Contractor. Provided that the Engineer shall, as soon after the occurrence of any such emergency as may be reasonably practicable, notify the Contractor thereof in writing.</p>
New Clause-4.18	<p>Confidentiality of Information</p> <p>I. The Contractor shall not use or divulge, except for the purpose of the Contract or with the written permission of the Employer, any information relating to the Works or the Project provided in the Contract or otherwise provided by the Employer, or the Engineer. The Contractor shall ensure that his sub-contractors of any tier shall be bound by a like confidentiality undertaking.</p> <p>II. The Employer, Engineer and any third party to whom an assignment has been made in accordance with New-clause 2.3/PCC may use any information provided by the Contractor in accordance with the Contract. The Employer shall use reasonable endeavours to ensure that the Engineer and any third party referred to in aforesaid New-clause 2.3/PCC shall not; divulge such information except for any purpose connected with the Contract.</p> <p>On completion of the works, the contractor shall arrange to furnish to the Employer two (2) bound sets of all "As Built" drawings for every component of the Works at his own cost, all such copies being on Polyester film of quality to be approved by the Engineer or his Representative. The Taking – over Certificate of the Works, as per the provisions of Clause 46.1/PCC herein, shall not be issued by the Engineer in the event of the Contractor's failure to furnish the aforesaid "As Built" drawings for the entire works.</p> <p>If the Contract specifies that the Contractor shall design any part of the Permanent Works, then unless otherwise stated in the Special Conditions of Contract:</p> <p>(a) the Contractor shall submit to the Engineer the Contractor's Documents for this part in accordance with the procedures specified in the Contract;</p> <p>(b) these Contractor's Documents shall be in accordance with the Specification and Drawings, shall be written in the language for communications defined in Sub-Clause 3/CC [Law and Language], and shall include additional information required by the Engineer to add to the Drawings for co-ordination of each Party's designs;</p> <p>(c) the Contractor shall be responsible for this part and it shall, when the Works are completed, be fit for such purposes for which the part is intended as are specified in the Contract; and</p>

	<p>(d) prior to the commencement of the Tests on Completion, the Contractor shall submit to the Engineer the “as-built” documents and operation and maintenance manuals in accordance with the Specification and in sufficient detail for the Employer to operate, maintain, dismantle, reassemble, adjust and repair this part of the Works. Such part shall not be considered to be completed for the purposes of taking-over under Sub-Clause 46.1/PCC [Taking Over of the Works and Sections] until these documents and manuals have been submitted to the Engineer.</p>
<p>New Clause-4.19</p>	<p>Performance Security</p> <p>The Contractor shall obtain (at his cost) a Performance Security and an additional Performance Security, if any in terms of ITB 35.5, for proper performance of the contract, for the amount, currencies and validity period for Performance Security stated in the Contract Data. If an amount is not stated in the Contract Data, this Sub-Clause shall not apply.</p> <p>The Contractor shall deliver the Performance Security and additional Performance Security, if any, to the Employer within 20 days after receiving the Letter of Acceptance, and shall send a copy to the Engineer. The Performance Security/additional Performance Security shall be issued by an entity and from within a country (or other jurisdiction) approved by the Employer and shall be in the form as given in Section 10 (Formats) or in another form specifically approved by the Employer.</p> <p>The procedure for obtaining Performance Guarantee is outlined below:</p> <p>The successful bidder shall have to submit a Performance Guarantee (PG) within 20 (Twenty-eight) days from the date of issue of Letter of Acceptance (LOA). Extension of time for submission of PG beyond 20 (Twenty) days and upto 60 days from the date of issue of LOA may be given by the Authority who is competent to sign the contract agreement. However, a penal interest of 12% per annum shall be charged for the delay beyond 20(Twenty) days, i.e. from 21st day after the date of issue of LOA. Further, if the 60th day happens to be a declared holiday in the concerned office of the Railway, submission of PG can be accepted on the next working day.</p> <p>In all other cases, if the Contractor fails to submit the requisite PG even after 60 days from the date of issue of LOA, the contract is liable to be terminated. In case contract is terminated railway shall be entitled to forfeit Earnest Money Deposit and other dues payable against that contract. In case a tenderer has not submitted Earnest Money Deposit on the strength of their registration as a Startup recognized by Department for promotion of industry and internal trade (DPIIT) under Ministry of Commerce and Industry, DPIIT shall be informed to this effect. The failed Contractor shall be debarred from participating in re-tender for that work.</p> <p>The Performance Security/additional Performance Security shall be, at the Contractor’s option, in any of the following forms:</p> <ul style="list-style-type: none"> (i) An unconditional Bank Guarantee in the prescribed format (ii) A Pay Order / Demand Draft drawn on a Scheduled / Nationalized Bank in India in favour of “Rail Infrastructure Development Company (Karnataka) Ltd” payable at Bangalore. (iii) FDR in favour of “Rail Infrastructure Development Company (Karnataka) Ltd.” (free from any encumbrance). (iv) A online bank transfer to K-RIDE account. <p>The Bank Guarantee shall be from a bank having minimum net-worth of over INR 500 million from the specified banks as under:</p>

- (i) a Schedule Bank in India, or
- (ii) a Foreign Bank having their operations in India, or
- (iii) a Foreign Bank which does not have operations in India is required to provide a counter-guarantee by State Bank of India,

The Scheduled Bank issuing the Bank Guarantee must be on “Structured Financial Messaging System (SFMS)” platform. A separate advice of the BG shall be invariably be sent by the issuing bank to the Employer’s Bank through SFMS and only after this the BG shall become operative and acceptable to the Employer.

The Issuing Bank shall send the SFMS to:

Beneficiary: Rail Infrastructure Development Company (Karnataka) Ltd. (K-RIDE)Bank
 Name: Canara Bank
 Branch: Prime Corporate Branch
 Account No. 0430201012110
 IFSC Code: CNRB0002636

In case the contractor is a JV;”the Performance Security/additional Performance Security, if any in terms of ITB 35.5, shall be submitted by each JV Partner separately on behalf of the JV in favour of K-RIDE in proportion of their respective percentage share specified in the JV Agreement. The additional Performance Security shall be submitted by the partner(s) responsible for execution of schedule(s) (as per JV agreement) against which additional Performance Security is required to be submitted in terms of ITB 35.5.

However, Submission of Performance Guarantee Security by individual partners on behalf of the JV shall in no way dilute their Joint & Several responsibility. The Employer shall be entitled to recover the amount of Bank Guarantees individually and / or from all the Partners jointly at its discretion.”

The Contractor shall ensure that the Performance Security/additional Performance Security is valid and enforceable until the Contractor has executed and completed the Works and remedied defects, if any. If the contractor does not complete the work for any reasons whatsoever, the terms of the Performance Security/ additional Performance Security specify its expiry date, and the Contractor has not become entitled to receive the Performance Certificate by the date 28 days prior to the expiry date, the Contractor shall be bound to extend the validity of the Performance Security/additional Performance Security until the Works have been completed and any defects have been remedied.

Failure of the successful Tenderer to furnish the required Performance Security shall be a ground for the annulment of the award of Contract and execution of the Tender Securing Declaration.

Release of performance security

- i. The whole or such portion of the Performance Security amount shall be liable to be forfeited by the Employer at the discretion of the Employer, in the event of any breach of Contract on the part of the Contractor.
- ii. After completion of the entire Work, the Performance Security shall be released to the Contractor, on issue of last Taking Over Certificate if more than one Certificate exist, by the Engineer, the release of Performance Security shall not relieve the Contractor from his obligations and liabilities, to make good that may be detected during the Defects Liability Period.

The Guarantees shall be unconditional and irrevocable. The Employer shall return the Performance Security to the Contractor within 21 days after receiving a copy of the Performance Certificate or passing of the Final Payment Certificate whichever is later. However, on completion of specified section(s) and Engineer certifies that no recoveries are pending in the contract.

The Employer shall return additional Performance Security submitted in terms of ITB 35.5 as per the following;

- (a) If the Contractor submits an application stating that all the works against the particular schedule(s)/bill(s) for which additional Performance Security was submitted in terms of ITB 35.5 have been completed in all respect, then the Employer, on being satisfied with the claim of the Contractor, shall return the full additional Performance Security against the particular schedule(s). Decision of the Employer regarding completion of works against a particular schedule/bill shall be final and binding on the Contractor.
- (b) If the Contractor submits an application stating that majority of the works (physical progress being not less than 90%) against the particular schedule(s)/bill(s) for which additional Performance Security was submitted in terms of ITB 35.5 have been completed and execution of balance works is held up for reasons not attributable to the Contractor, then the Employer, on being satisfied with the claim of the Contractor, shall return 75% of the amount of additional Performance Security against the particular schedule(s). The balance amount of additional Performance Security shall however be returned only after completion of the works against the particular schedule(s)/bill(s) for which additional Performance Security was submitted in terms of ITB 35.5, in all respects to the satisfaction of the Employer. Decision of the Employer regarding completion of works against a particular schedule/bill shall be final and binding on the Contractor.

Without limitation to the provisions of the rest of this Sub-Clause, whenever the Engineer determines an addition or a reduction to the Contract Price as a result of a change in cost and/or legislation or as a result of a Variation amounting to more than 25 percent of the portion of the Contract Price payable in a specific currency, the Contractor shall at the Engineer's request promptly submit Performance Guarantee @ 10% of the increased amount over the original contract price in a specific currency. On the other hand if the value of contract price decreases by more than 25% of the original contract price payable in a specific currency, Performance Guarantee @ 10% of the decrease in contract price from the original contract price in a specific currency shall be returned to the contractor, on his request.

Wherever the contract is terminated under Clause 49.7/PCC, the Performance Guarantee shall be encashed by the Employer:

- i) in full including additional Performance Guarantee amount, if any, taken in terms of clause 25.5 and 29 of ITT and not due for release on the date of issue of termination letter in terms of this clause, in case of termination of the contract as a whole; or
- ii) at the discretion of the Employer it may be encashed in part/parts proportionate to the Contract price of the bill/schedule to which the terminated part of work belongs i.e

$$P=(A \times B) \div C$$
 where

P=Proportionate Bank Guarantee Amount.

A=Contract price of the particular bill/schedule to which the terminated part of work belongs.

B=Performance Guarantee amount in terms of CC New-clause 4.19/PCC

	<p>C=Total Contract price.</p> <p>Plus additional performance Guarantee amount, if any, taken in terms of sub clause 25.5 and 29 of ITT and not due for release on the date of issue of termination letter in terms of this clause against this particular bill/schedule to which the terminated part of the work belongs, in case of termination in part/parts.</p> <p>The balance work should be got done separately, and independently by K-RIDE without risk and cost of the original contractor. The original contractor shall be debarred from participating in the tender for executing the balance work. If the failed contractor is a JV or a partnership firm, then every member/partner of such a firm would be debarred from participating in the tender for the balance work either in his/her individual capacity or as a partner of any other JV/partnership firm.</p> <p>In case the Contractor fails to perform the Contract or any JV partner fails to perform its obligations under the JV agreement, which is a part of this agreement, the Employer may issue notice of such default to the said JV partner or the JV (depending upon reasons of default) and declare the said JV partner or the JV as Poor Performer. The issue of such notice shall automatically debar the JV partner or JV, as the case may be, from participating in any K-RIDE tender from the date of issue of notice of default. The relevant performance security including additional performance security, if any, in terms of sub clauses 25.5 and 29 of ITT submitted by the Contractor or submitted on behalf of JV partner to the extent not due for release at the time of contemplation of such action shall be encashed and forfeited either fully or in proportion of the percentage share of that partner in the JV agreement, as the case may be.</p>
<p>New Clause-4.20</p>	<p>Security Deposit: The Security Deposit shall be 5% of the contract value. Security Deposit may be deposited by the Contractor before release of first on account bill in cash or Term Deposit Receipt issued from Scheduled Bank, or may be recovered at the rate defined in this section PCC, the bill amount till the full Security Deposit is recovered. Provided also that in case of defaulting Contractor, the Employer may retain any amount due for payment to the Contractor on the pending "on account bills" so that the amounts so retained (including amount guaranteed through Performance Security) may not exceed 10% of the total value of the contract. The security deposit may be recovered at the rate 6% of bill amount till the security deposit is recovered.</p> <p>Further, in case of contracts having value equal to or more than ₹ 50 crore (Rs Fifty crore) the Security Deposit may be deposited as Bank Guarantee Bond also, issued by a scheduled bank after execution of contract documents, but before payment of 1st on account bill. Provided further that the validity of Bank Guarantee Bond shall be extended from time to time, depending upon extension of contract granted in terms Clause No 26 of PCC.</p> <p>Further, in case Security Deposit has been submitted as Term Deposit Receipt/Bank Guarantee Bond in full amount, the Bid security by Contractor with his tender will be returned by K-RIDE.</p> <p>Note: After the work is physically completed as certified by competent authority, Security Deposit recovered from the running bills of a Contractor can be returned to him, if he so desires, in lieu of Term Deposit Receipt/irrevocable Bank Guarantee for equivalent amount from Scheduled Bank, to be submitted by him.</p> <p>4.2.b(i) Refund of Security Deposit: Security Deposit mentioned in clause above shall be returned to the Contractor along with or after, the following:</p> <p>(a) Final Payment of the Contract and</p>

	<p>(b) Execution of Final Supplementary Agreement or Certification by Engineer that K-RIDE has No Claim on Contractor and</p> <p>(c) Maintenance Certificate issued, on expiry of the maintenance period.</p> <p>4.2.b(ii) Forfeiture of Security Deposit: Whenever the contract is rescinded as a whole under clause 49 of CC/PCC, the Security Deposit already with K-RIDE under the contract shall be forfeited. However, in case the contract is rescinded in part or parts under clause 49 of CC/PCC, the Security Deposit shall not be forfeited.</p> <p>4.2.(c) No interest shall be payable upon the Bid Security and Security Deposit or amounts payable to the Contractor under the Contract, but Government Securities deposited in terms of New-Clause 4.19/PCC of this clause will be payable with interest accrued thereon.</p>
<p>New Clause -4.21</p>	<p>Contractor Representative:</p> <p>The Contractor shall depute his Representative to attend all the review meetings notified by the Engineer.</p> <p>Facilities for and Co-ordination with Others</p> <p>The Contractor shall not impede and shall afford all necessary facilities, access and/or services to the Employer, Engineer, Designated Contractors, utility undertakings, other relevant authorities and other contractors (whether employed by the Employer or not) who are carrying out on, or in the vicinity of, the Site, works not included in the Contract but forming part of the Project:</p> <p>A. The Contractor shall take all reasonable steps to ensure that the Works are co-ordinated and integrated with the Design, manufacture, installation execution and testing of such other works and shall in particular (but without limitation):</p> <p>(i) comply with any direction which the Engineer may give for the integration of the Design with the design of any other part of the Project;</p> <p>(ii) consult, liaise and co-operate with those responsible for carrying out such other works, including where necessary, in the preparation of the respective designs, the preparation of co-ordinated programmes, method statements, co-ordination drawings and specifications together with arrangements of service priorities and zoning;</p> <p>B. The Contractor shall undertake Design co-ordination with other contractors who are carrying out works forming part of the Project as described in the Employer's Requirements. At the end of each such co-ordination period, the Contractor and the other contractor with whose works the interface period refers shall jointly state in writing that their design co-ordination activities are complete and that their respective designs are integrated and can be finalised without interference with each other's designs or the designs with which their designs have already been integrated.</p> <p>A copy of this joint written statement shall be provided to the Engineer within 7 days of the end of the said design co-ordination period. Unless and until copies of all relevant and necessary design co-ordination statements have been submitted to the Engineer, the Engineer shall be entitled to suspend any review or further review of the Contractor's or the other contractor's design submissions. Such suspension shall not be grounds for the</p>

	<p>Contractor to claim nor shall be entitled to receive an extension of time or additional payments.</p> <p>C. The Contractor shall share within the Site, staging, storage and unloading areas for the use of Designated Contractors, if any, who are undertaking civil work, fare collection system, supply, testing and commissioning of Rolling Stock, escalators, lifts, signalling and telecommunications and traction power installation works, etc. Separate locations shall be provided for each such contractor. The exact size and location of these staging, storage and unloading areas, and the commencement date shall be co-ordinated and agreed during the design interface period with each Designated Contractor.</p> <p>D. Any other contract which depends for its execution on the Contract or upon which the Contract is dependent for its own execution shall be identified by the Engineer as a "Designated Contract". The Contractor shall provide attendance on Designated Contractors in accordance with the Employer's Requirements and as instructed by the Engineer. The identity of the contractor for a Designated Contract may not be known before the execution of the Contract but this shall not be a ground for the Contractor to object to the subsequent appointment of a Designated Contractor</p> <p>E. The Contractor shall in accordance with the requirements of the Engineer co-ordinate his own Works with that of Designated Contractors through Co-ordinated Installation Programme (CIP) stated in the Employer's Requirements, or as the Engineer may require, and shall afford the Designated Contractors all reasonable opportunities for carrying out their works.</p> <p>F. The Contractor shall afford all reasonable opportunities, for carrying out their work, to other contractors employed by the Employer and their workmen respectively and the workmen of the Employer who may be engaged on or near the Site of any work, ancillary to the Works, but, not included in the Contract and shall not cause them inconvenience.</p> <p>G. If the Contractor shall suffer delay by reason of failure by any Designated Contractor to meet the specified installation interfacing and co-ordination, completion dates, which delay shall be caused otherwise than by fault of the Contractor, or, if compliance with sub-clause (f) herein shall involve the Contractor in delay beyond that which could be reasonably foreseen by an experienced contractor at the time of tender, then the Engineer shall take such delay into account in determining any extension of time to which the Contractor is entitled under the Contract.</p> <p>H. It shall be the responsibility of the Contractor to ensure that the full extent of the Works under the Contract and the works to be carried out by Designated Contractors within the Works or, in, on, under, through and over the Site are co-ordinated and integrated in their design, manufacture, installation and construction. Such responsibility shall neither be mitigated nor in any other way affected by virtue of similar responsibilities being placed on other contractors.</p> <p>The Contractor shall be deemed to have made adequate allowance in the Contract Price and in the Works Programme in respect of these obligations.</p> <p>If any act or omission of the Contractor whether directly or indirectly results in the delay in the execution of the works of a Designated Contractor, the Contractor, in addition to his liability in respect of liquidated damages if they become due, shall pay to the Employer, or the Engineer may deduct from Interim Payment Certificates such amount as the Engineer shall have certified in respect of additional payments or costs to the Designated Contractor in respect of such delay.</p>
New Clause-4.22	DELETED

New Clause-4.23	DELETED
New Clause-4.24	<p>Co-operation</p> <p>The Contractor shall, as specified in the Contract or as instructed by the Engineer, allow appropriate opportunities for carrying out work to:</p> <ul style="list-style-type: none"> (a) the Employer's Personnel, (b) any other contractors employed by the Employer, and (c) the personnel of any legally constituted public authorities, <p>who may be employed in the execution on or near the Site of any work not included in the Contract.</p> <p>Any such instruction shall constitute a Variation if and to the extent that it causes the Contractor to incur Unforeseeable Cost. Services for these personnel and other contractors may include the use of Contractor's Equipment, Temporary Works or access arrangements which are the responsibility of the Contractor.</p> <p>If, under the Contract, the Employer is required to give to the Contractor possession of any foundation, structure, plant or means of access in accordance with Contractor's Documents, the Contractor shall submit such documents to the Engineer in the time and manner stated in the Specification.</p>
New Clause-4.25	<p>Setting Out</p> <p>The Contractor shall set out the Works in relation to original points, lines and levels of reference specified in the Contract or notified by the Engineer. The Contractor shall be responsible for the correct positioning of all parts of the Works, and shall rectify any error in the positions, levels, dimensions or alignment of the works, notifying the Engineer within 28 days of the date of commencement</p> <p>In the event of such discrepancy arising during the course of the work, for which Employer's documents are handed over after the date of commencement, the contractor shall seek clarifications within 14 days of receipt of such documents</p> <p>The Employer shall be responsible for any errors in these specified or notified items of reference, but the Contractor shall use reasonable efforts to verify their accuracy before they are used.</p> <p>Contractor shall promptly notify the Employer and the Engineer of any error, omission, fault, or any other defect in the design, drawing or specifications for the works, which he discovers when reviewing the Contract Documents, and in the process of execution of the Works. The Contractor shall be responsible to ensure correlation in various drawings and bill of quantities, before commencement and execution of work. In case of any discrepancy the Contractor shall bring it to notice of the Engineer for clarification within 28 days of the issue of Letter of Acceptance. In the event of such discrepancy arising during the course of the work, for which drawings are given after the date of issue of Letter of Acceptance, the Contractor shall seek clarifications within 14 days of receipt of such drawings.</p> <p>Notwithstanding with any other provision, the Contractor shall have to pay penalty for damage to Railway cable in terms of clause C 15 of the JPO as given in para 1.2 of Chapter 1. (Safety and Security) of Section 8 and shall also indemnify the Employer against any losses, damages to property or life in terms of para 1.11 and 1.12 of the chapter 1. (Safety and Security) of Section 8.</p>
New Clause-4.26	Safety Procedures

The Contractor shall follow the provisions laid down in Chapter 1. (Safety and Security) of Section 8 and shall:

- (a) comply with all applicable safety regulations,
- (b) take care for the safety of all persons entitled to be on the Site,
- (c) use reasonable efforts to keep the Site and Works clear of unnecessary obstruction so as to avoid danger to these persons,
- (d) provide fencing, lighting, guarding and watching of the Works until completion and taking over under Clause 46/PCC [Employer's Taking Over], and
- (e) provide any Temporary Works (including roadways, footways, guards and fences) which may be necessary, because of the execution of the Works, for the use and protection of the public and of owners and occupiers of adjacent land.

Additional Safety Precautions

- (1) The Contractor shall comply with all the precautions as required for the safety of the workmen by the I.L.O Convention No.62 as far as they are applicable to the Contract. The Contractor shall provide all necessary safety appliances; such as safety goggles, helmets, masks, etc. to the workmen and the staff.
- (2) Suitable scaffolds shall be provided for workmen for all work that cannot safely be done from the ground, or from solid construction except for such short period work as can be done safely from ladders. When a ladder is used, an extra labourer shall be engaged for holding the ladder and if the ladder is used for carrying materials as well, suitable foot-holds and hand-holds shall be provided on the ladder, which shall be given an inclination not steeper than 1/4 to 1 (1/4 horizontal in 1 vertical).
- (3) Scaffolding or staging more than 3.25 metres above the ground or floor, swung or suspended from an overhead support or erected with stationary support, shall have a guard rail properly attached, bolted, braced and otherwise secured at least 1 metre high above the floor or platform of such scaffolding or staging and extending along the entire length of the outside and ends thereof with only such openings as maybe necessary for the delivery of materials. Such scaffolding or staging shall be so fastened as to prevent it from swaying in from the support or structure.
- (4) Working platforms, gangways and stairways shall be so constructed that they do not sag unduly or unequally, and if the height of any platform or gangway or stairway is more than 3.25 metres above ground level or floor level, it shall have closely spaced boards, have adequate width and be suitably provided with guard rails as described in (3) above.
- (5) Every opening in the floor of a structure or in a working platform shall be provided with suitable means to prevent fall of persons or materials by providing suitable fencing or railing with a minimum height of one metre.
- (6) Safe means of access and egress shall be provided to all working platforms and other working places. Every ladder shall be securely fixed. No portable single ladder shall be over 9 metres in length. The width between side rails in a rung ladder shall in no case be less than 30 cm for ladders up to and including 3 metres in length. For longer ladders the width shall be increased at least 6 mm for each additional 30 cm of length. Spacing of steps shall be uniform and shall not exceed 30 cm.

- (7) Adequate precautions shall be taken to prevent danger from electrical equipment. Adequate safety measures shall be taken when any work is undertaken near any live highly charged electric wire. Necessary shutdown may be arranged, where and whenever essential. All rules in force in this connection shall be fully complied with. The Contractor shall ensure all precautions to prevent any accidents due to electrocution or otherwise.
- (8) No materials on any of the sites shall be so stacked or placed as to cause danger or inconvenience to any person or the public. The Contractor shall provide all necessary fencing and lights to protect the public from accidents and shall be bound to bear the expenses of defending every suit, action or other proceedings at law that may be brought by any person for injury sustained owing to neglect of the above precautions and to pay any damages and costs which may be awarded in any such suit, action or proceedings to any such person or which may with the consent of the Contractor be paid to compromise any claim by any such person.
- (9) Excavation and Trenching : All trenches, 1.5 metres or more in depth, shall at all times be supplied with at least one ladder for each 20 metres in length or fraction thereof, Ladders shall be extended from the bottom of the trench to at least 1 metre above the surface of the ground. The sides of a trench, which is 1.5 metres or more in depth shall be stepped back to provide a suitable slope, or be securely held by timber bracing so as to avoid the danger of side collapse. Excavated material shall not be placed within 1.5 metres of the edge of any trench or half the depth of the trench, whichever is more. Excavation shall be made from the top to the bottom. Under no circumstances shall undermining or undercutting be done.
- (10) Demolition : Before any demolition work is commenced and also during the process of the work :
- (a) All roads and open areas adjacent to the work site shall either be closed or suitably protected.
 - (b) No electric cable or apparatus, which is liable to be a source of danger other than a cable or apparatus used by operators, shall remain electrically charged:
 - (c) All practical steps shall be taken to prevent danger to persons employed by the Employer, from risk of fire or explosion, or flooding. No floor, roof or other part of a building shall be so overloaded with debris or materials as to render it unsafe.
- (11) All necessary personal safety equipment as considered adequate by the Engineer shall be available for use of persons employed on the site and maintained in a condition suitable for immediate use; and the Contractor shall take adequate steps to ensure proper use of such equipment by those concerned.
- (a) Workers employed on mixing asphaltic materials, cement, lime mortars, concrete etc. shall be provided with protective footwear and protective goggles.
 - (b) Those engaged in handling any material, which is injurious to the eyes, shall be provided with protective goggles.
 - (c) Those engaged in welding works shall be provided with welder's protective eye-shield.

	<p>(d) Stone breakers shall be provided with protective goggles and protective clothing and seated at sufficiently safe intervals.</p> <p>(e) When workers are employed in sewers and manhole, which are in use, the contractor shall ensure that manhole covers are open and manholes are ventilated at least for an hour before workers are allowed to go into them. Manholes so open shall be cordoned off with suitable railing and provide warning signals or boards to prevent accidents to the public.</p> <p>(12) The Contractor shall not employ men below the age of 18 years and women, on the work of painting with products containing lead in any form. Whenever men above the age of 18 years are employed on the work of lead painting, the following precautions shall be taken</p> <p>(a) No paint containing lead or lead products shall be used except in the form of paste or readymade paint.</p> <p>(b) Suitable face masks shall be supplied for use by workers when paint is applied in the form of spray or a surface having lead paint dry rubbed and scrapped.</p> <p>(c) Overalls shall be supplied by the Contractor to workmen and adequate facilities shall be provided to enable workers to wash during and at the close of any day's work.</p> <p>13) When work is performed near any place where there is risk of drowning all necessary equipment shall be provided and kept ready for use and all necessary steps taken for prompt first aid treatment of all injuries likely to be sustained during the course of the work.</p> <p>(14) Use of hoisting machines and tackle including their attachments, anchorage and supports shall conform to the following:</p> <p>(i) These shall be of good mechanical construction, sound material and adequate strength and free from patent defects and shall be kept in good working order, be regularly inspected and properly maintained.</p> <p>(ii) Every rope used in hoisting or lowering materials or as a means of suspension shall be of durable quality and adequate strength, and free from defects</p> <p>a) Every crane driver or hoisting appliance operator shall be properly qualified and no person under the age of 21 shall be in charge of any hoisting machine including scaffold equipment. Only trained men over the age of 21 shall be permitted to give signals to such plant and appliance operators.</p> <p>For every hoisting machine and every chain hook, shackle, swivel and pulley block used in hoisting, lowering or as means of suspension, safe working load shall be ascertained by adequate means. Every hoisting machine and all gear referred to above shall be plainly marked with safe working load. In case of a hoisting machine or a variable safe working load, each safe working load and conditions under which it is applicable shall</p>
--	--

be clearly indicated. No part of any machine or any gear referred to in the paragraph above shall be loaded beyond safe working load except for the purpose of testing.

- b) In case of the Employer's machine, safe working load shall be notified by the Engineer or his Representative. As regards Contractor's machines, the Contractor shall notify safe working load of each machine to the Engineer or his Representative, whenever he brings it to the site of work and get it verified by him.
- (15) Motors, gearing, transmission, electric wiring and other dangerous parts of hoisting appliances shall be provided with efficient safeguards; hoisting appliances shall be provided with such means as will reduce the risk of accident during descent of load to the minimum. Adequate precautions shall be taken to reduce to the minimum risk of any part of a suspended load becoming accidentally displaced. When workers are employed on electrical installations, which are already energised, insulating mats, working apparel such as gloves, sleeves and boots, as may be necessary, shall be provided. Workers shall not wear any rings, watches and carry keys or other materials which are good conductor of electricity.
- (16) All scaffolds, ladders and other safety devices mentioned or described herein shall be maintained in a safe condition and no scaffold, ladder or equipment shall be altered or removed while it is in use. Adequate washing facilities shall be provided at or near places of work.
- (17) These safety provisions shall be brought to the notice of all concerned by displaying on a notice board at a prominent place at the work location. Persons responsible for ensuring compliance with the Safety Code shall be named therein by the Contractor.
- (18) To ensure effective enforcement of the rules and regulations relating to safety precautions, arrangements made by the contractor shall be open to inspection by the Engineer or his Representative.
- (19) Notwithstanding anything contained in conditions (1) to (17) above, the Contractor shall at its own costs, remain liable to comply with the provisions of all acts, rules, regulations, and bylaws for the time being in force in India and applicable in this matter.
- (20) For work carried out in the vicinity of any wharf or quay, the Contractor shall abide by all the provisions of the Dock Workers (Safety, Health and Welfare) Scheme, 1961.
- (21) The Contractor shall at his own expense provide protective safety Equipment like gloves and footwear for all labour engaged on concrete mixing work and all other types of working involving the use of tar, cement, etc. to the satisfaction of the Engineer or his Representative, and on his failure to do so, the employer shall be entitled to provide the same and recover the cost from the Contractor.
- The Contractor shall be responsible for observance, by the sub-contractors, of the foregoing provisions.
- (23) All construction labour at all-time shall use personal protective equipment like, safety shoes, helmets and reflective jackets in all activities at site. This shall be ensured without fail on each work site. Failing to comply with this, provision shall attract penalty of Rs. 500/- per occasion per staff.

Notwithstanding with any other provision, the Contractor shall have to pay penalty for damage to Railway cable in terms of clause C 15 of the JPO as given in para 1.2 of Chapter 1. (Safety and Security) of Section 8 and shall also indemnify the Employer

	<p>against any losses, damages to property or life in terms of para 1.11 and 1.12 of the chapter 1. (Safety and Security) of Section 8).</p>
<p>New Clause-4.27</p>	<p>Quality Assurance</p> <p>The Contractor shall institute a quality assurance system to demonstrate compliance with the requirements of the Contract. The system shall be in accordance with the details stated in the Contract. The Engineer shall be entitled to audit any aspect of the system.</p> <p>Details of all procedures and compliance documents shall be submitted to the Engineer for information before each design and execution stage is commenced. When any document of a technical nature is issued to the Engineer, evidence of the prior approval by the Contractor himself shall be apparent on the document itself.</p> <p>Compliance with the quality assurance system shall not relieve the Contractor of any of his duties, obligations or responsibilities under the Contract.</p> <p>Quality Control</p> <p>Within 28 days of the issue of the Letter of acceptance, the Contractor shall submit to the Engineer, for his consent, his proposed Site Quality Plan based on the Outline Quality Plan and the Employer's Requirements. The quality manual should address the quality system as required by ISO 9001-1991. Any supplement to the Site Quality Plan shall be submitted at least 14 days before commencement of the relevant work.</p> <p>Upon the Engineer notifying his consent to the Site Quality Plan, or any supplement thereto, the Contractor shall, adhere to the principles and procedures contained in such document, except where the Engineer gives his consent to any amended or varied version thereof. The Contractor shall cause any sub-contractors to adhere to this Plan.</p> <p>The Contractor shall appoint a suitably qualified and experienced person, not otherwise engaged in the performance of the Contract, to act as manager of the quality assurance system and shall provide such other personnel and resources as required to ensure effective operation of the quality assurance system. The said manager shall carry out audits of the application of the quality assurance system, and ensure effective quality control and delivery of quality assurance.</p> <p>The Contractor shall provide all necessary access, assistance and facilities to enable the Engineer to carry out surveillance visits both on and off the Site to verify that the quality assurance system is being properly and fully implemented. No extra payment shall be made in this regard and the cost of the Work under this element shall be deemed to be included in the Contract Price.</p>
<p>New Clause-4.28</p>	<p>Site Data</p> <p>The Employer shall have made available to the Contractor for his information, prior to the Base Date, all relevant data in the Employer's possession on sub-surface and hydrological conditions at the Site, including environmental aspects. The Employer shall similarly make available to the Contractor all such data which come into the Employer's possession after the Base Date. The Contractor shall be responsible for interpreting all such data.</p> <p>To the extent which was practicable (taking account of cost and time), the Contractor shall be deemed to have obtained all necessary information as to risks, contingencies and other circumstances which may influence or affect the Bid or Works. To the same extent, the Contractor shall be deemed to have inspected and examined the Site, its surroundings, the above data and other available information, and to have been satisfied before submitting the Bid as to all relevant matters, including (without limitation):</p>

	<ul style="list-style-type: none"> (a) the form and nature of the Site, including sub-surface conditions, (b) the hydrological and climatic conditions, (c) the extent and nature of the work and Goods necessary for the execution and completion of the Works and the remedying of any defects, (d) the Laws, procedures and labour practices of the Country, and (e) the Contractor's requirements for access, accommodation, facilities, personnel, power, transport, water and other services. (f) Data made available by the Employer in accordance with the preceding paragraph shall be deemed to include data listed elsewhere in the contract as open for inspection at the address stipulated in the Contract.
<p>New Clause-4.29</p>	<p>Sufficiency of the Accepted Contract Amount</p> <p>The Contractor shall be deemed to:</p> <ul style="list-style-type: none"> a) have satisfied himself as to the correctness and sufficiency of the Accepted Contract Amount, and b) have based the Accepted Contract Amount on the data, interpretations, necessary information, inspections, examinations and satisfaction as to all relevant matters referred to in New-Clause 4.28/PCC [Site Data]. <p>Unless otherwise stated in the Contract, the Accepted Contract Amount covers all the Contractor's obligations under the Contract (including those under Provisional Sums, if any) and all things necessary for the proper execution and completion of the Works and the remedying of any defects.</p>
<p>New Clause-4.30</p>	<p>Unforeseeable Physical Conditions</p> <p>In this Sub-Clause, "physical conditions" means natural physical conditions and man-made and other physical obstructions and pollutants, which the Contractor encounters at the Site when executing the Works, including sub-surface and hydrological conditions but excluding climatic conditions.</p> <p>If the Contractor encounters adverse physical conditions which he considers to have been Unforeseeable, the Contractor shall give notice to the Engineer as soon as practicable.</p> <p>This notice shall describe the physical conditions, so that they can be inspected by the Engineer, and shall set out the reasons why the Contractor considers them to be Unforeseeable. The Contractor shall continue executing the Works, using such proper and reasonable measures as are appropriate for the physical conditions, and shall comply with any instructions which the Engineer may give. If an instruction constitutes a Variation, Clause 34/PCC [Variations and Adjustments] shall apply.</p> <p>If and to the extent that the Contractor encounters physical conditions which are Unforeseeable, gives such a notice, and suffers delay and/or incurs Cost due to these conditions, the Contractor shall be entitled subject to Sub-Clause 4.1/SCC [Contractor's Claims] to:</p> <ul style="list-style-type: none"> (a) An extension of time for any such delay, if completion is or will be delayed, under Sub-Clause 26.5/PCC [Extension of Time for Completion], and (b) Payment of any such Cost, which shall be included in the Contract Price.

	<p>After receiving such notice and inspecting and/or investigating these physical conditions, the Engineer shall proceed in accordance with New-Clause 3.5/PCC [Determinations] to agree or determine (i) whether and (if so) to what extent these physical conditions were Unforeseeable, and (ii) the matters described in sub-paragraphs (a) and (b) above related to this extent.</p> <p>However, before additional Cost is finally agreed or determined under sub-paragraph (ii), the Engineer may also review whether other physical conditions in similar parts of the Works (if any) were more favourable than could reasonably have been foreseen when the Contractor submitted the Bid. If and to the extent that these more favourable conditions were encountered, the Engineer may proceed in accordance with New-Clause 3.5/PCC [Determinations] to agree or determine the reductions in Cost which were due to these conditions, which may be included (as deductions) in the Contract Price and Payment Certificates. However, the net effect of all adjustments under sub-paragraph (b) and all these reductions, for all the physical conditions encountered in similar parts of the Works, shall not result in a net reduction in the Contract Price.</p> <p>The Engineer may take account of any evidence of the physical conditions foreseen by the Contractor when submitting the Bid, which may be made available by the Contractor, but shall not be bound by any such evidence.</p>
<p>New Clause-4.31</p>	<p>Rights of Way and Facilities</p> <p>The Contractor shall bear all costs and charges for special and/or temporary rights-of-way which he may require, including those for access to the Site. The Contractor shall also obtain, at his risk and cost, any additional facilities outside the Site which he may require for the purposes of the Works.</p> <p>In case any operation connected with traffic necessitates diversion, obstruction or closure of any road, railway or any other right of way, the approval of the Engineer and the concerned authorities shall be obtained well in advance by the Contractor.</p> <p>Provided that if it is found necessary for the Contractor to move one or more loads of heavy constructional plants and equipment, materials or Pre-constructed units or parts of units of work over roads, highways, bridges on which such oversized and overweight items that are not normally to be moved, the contractor shall obtain prior permission from the concerned authorities.</p> <p>Payments for complying with the requirements, if any, for protection or strengthening of the roads, highways or bridges shall be made by the contractor and such expenses shall be deemed to be included in his quoted contract price.</p>
<p>New Clause-4.32</p>	<p>Avoidance of Interference</p> <p>The Contractor shall not interfere unnecessarily or improperly with:</p> <ul style="list-style-type: none"> a) the convenience of the public, or b) the access to and use and occupation of all roads and footpaths, irrespective of whether they are public or in the possession of the Employer or of others or c) Passenger amenities at stations and station platforms. <p>The Contractor shall indemnify and hold the Employer harmless against and from all damages, losses and expenses (including legal fees and expenses) resulting from any such unnecessary or improper interference.</p>

New Clause-4.33	<p>Access Route</p> <p>The Contractor shall be deemed to have been satisfied as to the suitability and availability of access routes to the Site. The Contractor shall use reasonable efforts to prevent any road or bridge from being damaged by the Contractor's traffic or by the Contractor's Personnel. These efforts shall include the proper use of appropriate vehicles and routes.</p> <p>Except as otherwise stated in these Conditions:</p> <ul style="list-style-type: none"> (a) the Contractor shall (as between the Parties) be responsible for any maintenance which may be required for his use of access routes; (b) the Contractor shall provide all necessary signs or directions along access routes, and shall obtain any permission which may be required from the relevant authorities for his use of routes, signs and directions; (c) the Employer shall not be responsible for any claims which may arise from the use or otherwise of any access route; (d) the Employer does not guarantee the suitability or availability of particular access routes; and (e) Costs due to non-suitability or non-availability, for the use required by the Contractor, of access routes shall be borne by the Contractor.
New Clause-4.34	<p>Transport of Goods</p> <p>Unless otherwise stated in the Special Conditions of Contract:</p> <ul style="list-style-type: none"> (a) the Contractor shall give the Engineer not less than 21 days' notice of the date on which any Plant or a major item of other Goods will be delivered to the Site; (b) the Contractor shall be responsible for packing, loading, transporting, receiving, unloading, storing and protecting all Goods and other things required for the Works; and (c) the Contractor shall indemnify and hold the Employer harmless against and from all damages, losses and expenses (including legal fees and expenses) resulting from the transport of Goods, and shall negotiate and pay all claims arising from their transport.
New Clause-4.35	<p>Contractor's Equipment</p> <p>The Contractor shall be responsible for all Contractors' Equipment. When brought on to the Site, Contractor's Equipment shall be deemed to be exclusively intended for the execution of the Works. The Contractor shall not remove from the Site any major items of Contractor's Equipment without the consent of the Engineer. However, consent shall not be required for vehicles transporting Goods or Contractor's Personnel off Site</p> <p>In the event of Contractor imports any equipment the following shall apply"</p> <p>A. Custom Clearance: The Employer will assist the contractor, when required by furnishing letters of recommendation for obtaining expeditious clearance through customs of constructional plants, material and other things required for the works and then for re-export, if any. The following publications, may be referred to by the contractor for guidance about custom regulations etc :</p> <ul style="list-style-type: none"> i. Import & export policy, together with amendments, if any, published by Govt. of India, Ministry of Commerce.. ii. Hand Book of Procedures, together with amendments, if any, Volume 1 and 2 published by Ministry of Commerce.

	<p>iii. Customs Tariff, together with amendments, if any published by Central Customs. The Contractor shall be responsible to follow the latest rules and regulations without any liability of the Employer.</p> <p>B. Re-export of Contractors equipment: The contractor shall obtain all the relevant information regarding procedure for the import and subsequent re-export of his equipment and materials from the Chief Controller of Imports and Exports, Bangalore, and shall inform himself and keep himself informed on the details of custom charges and draw-back regulations as applicable to the items of Constructional plant. The contractor shall provide the necessary guarantee/bonds where these are required by the customs notwithstanding that import licenses may be granted in the name of Employer.</p> <p>C. Notwithstanding the provisions mentioned above, Contractor's Equipment, including essential spare parts therefore, imported by the Contractor for the sole purpose of executing the Contract shall be temporarily exempt from the payment of import duties and taxes upon initial importation, provided the Contractor shall post with the customs authorities at the port of entry an approved export bond or bank guarantee, valid until the Time for Completion plus six months, in an amount equal to the full import duties and taxes which would be payable on the assessed imported value of such Contractor's Equipment and spare parts, and callable in the event the Contractor's Equipment is not exported from the Country on completion of the Contract. A copy of the bond or bank guarantee endorsed by the custom authorities shall be provided by the Contractor to the Employer upon the importation of individual items of Contractor's Equipment and spare parts. Upon export of individual items of Contractor's Equipment or spare parts, or upon the completion of the Contract, Contractor shall prepare for approval by the customs authority the authorities, an assessment of the residual value of the Contractor's Equipment and spare parts to be exported based on the depreciation scale(s) and other criteria used by the customs authorities for such purposes under the provisions of the applicable Laws. Import duties and taxes shall be due and payable to the customs authorities by the Contractor on (a) the difference between the initial imported value and the residual value of the contractor's equipment and spare parts to be exported and (b) on the initial imported value that contractor's equipment and spare parts remaining in the Country after completion of the Contract. Upon payment of such dues within 28 days of being invoiced, the bond or bank guarantee shall be reduced or released accordingly; otherwise the security shall be called in the full amount remaining in the Country.</p> <p>D. Conditions of hire of the contractor's equipment: A certified copy of the agreement in respect of any item of Equipment held by contractor under any agreement for hire or hire purchase thereof, shall be supplied to the Engineer/Employer."</p>
New Clause-4.36	<p>Protection of the Environment</p> <p>The Contractor shall take all reasonable steps to protect the environment (both on and off the Site) and to limit damage and nuisance to people and property resulting from pollution, noise and other results of his operations.</p> <p>The Contractor shall ensure that emissions, surface discharges and effluent from the Contractor's activities shall not exceed the values stated in the Specification or prescribed by applicable Laws.</p>
New Clause-4.37	<p>Electricity, Water and Gas</p> <p>The Contractor shall, except as stated below, be responsible for the provision of all power, water and other services he may require.</p>

	<p>The Contractor shall be entitled to use for the purposes of the Works such supplies of electricity, water, gas and other services as may be available on the Site and of which details and prices are given in the Specification. The Contractor shall, at his risk and cost, provide any apparatus necessary for his use of these services and for measuring the quantities consumed.</p> <p>The quantities consumed and the amounts due (at these prices) for such services shall be agreed or determined by the Engineer in accordance with New-Clause 2.4/PCC [Employer's Claims] and New-Clause 3.5/PCC [Determinations]. The Contractor shall pay these amounts to the Employer.</p>
<p>New Clause-4.38</p>	<p>Employer's, Equipment and Free-Issue Material</p> <p>The Employer shall make the Employer's Equipment (if any) available for the use of the Contractor in the execution of the Works in accordance with the details, arrangements and prices stated in the Specification. Unless otherwise stated in the Specification:</p> <p>(a) the Employer shall be responsible for the Employer's Equipment, except that</p> <p>(b) the Contractor shall be responsible for each item of Employer's Equipment whilst any of the Contractor's Personnel is operating it, driving it, directing it or in possession or control of it.</p> <p>The appropriate quantities and the amounts due (at such stated prices) for the use of Employer's Equipment shall be agreed or determined by the Engineer in accordance with New-Clause 2.4/PCC [Employer's Claims] and New-Clause 3.5/PCC [Determinations]. The Contractor shall pay these amounts to the Employer.</p> <p>The Employer shall supply, free of charge, the "free-issue materials" (if any) in accordance with the details stated in the Contract data.</p> <p>The Employer shall, at his risk and cost, provide these materials at the time and place specified in the Contract. The Contractor shall then visually inspect them, and shall promptly give notice to the Engineer of any shortage, defect or default in these materials. Unless otherwise agreed by both Parties, the Employer shall immediately rectify the notified shortage, defect or default.</p> <p>In case materials are handed over, in accordance with the procedure prescribed by the Engineer, after proper measurement and accounted for, the contractor shall be solely liable for any shortage, damage, defect or default in such material, and shall indemnify the Employer until the final account of materials is made by the Contractor on completion of the work.</p>
<p>New Clause-4.39</p>	<p>Progress Reports</p> <p>Unless otherwise stated in the Special Conditions of Contract, monthly progress reports shall be prepared by the Contractor and submitted to the Engineer in six copies. The first report shall cover the period up to the end of the first calendar month following the Commencement Date. Reports shall be submitted monthly thereafter, each within 7 days after the last day of the period to which it relates.</p> <p>Reporting shall continue until the Contractor has completed all work which is known to be outstanding at the completion date stated in the Taking-Over Certificate for the Works.</p> <p>Each report shall include:</p> <p>Charts and detailed descriptions of progress, including each stage of design (if any), Contractor's Documents, procurement, manufacture, delivery to Site, construction, erection and testing; and including these stages for work by each nominated Subcontractor (as defined in Clause 7/PCC (Nominated Subcontractors)),</p>

	<p>photographs showing the status of manufacture and of progress on the Site; for the manufacture of each main item of Plant and Materials, the name of the manufacturer, manufacture location, percentage progress, and the actual or expected dates of:</p> <ul style="list-style-type: none"> (i) commencement of manufacture, (ii) Contractor's inspections, (iii) tests, and (iv) shipment and arrival at the Site; <p>the details described in Sub-Clause 1.10/SCC of PCC [Records of Contractor's Personnel and Equipment];</p> <ul style="list-style-type: none"> a) copies of quality assurance documents, test results and certificates of Materials; b) list of notices given under New-Clause 2.4/PCC [Employer's Claims] and notices given under Sub-Clause 4.1/SCC [Contractor's Claims]; c) safety statistics, including details of any hazardous incidents and activities relating to environmental aspects and public relations; and d) Comparisons of actual and planned progress of all activities, with details of any events or circumstances which may jeopardise the completion in accordance with the Contract, and the measures being (or to be) adopted to overcome delays.
New Clause-4.40	<p>Security of the Site</p> <p>Unless otherwise stated in the Special Conditions of Contract:</p> <ul style="list-style-type: none"> (a) the Contractor shall be responsible for keeping unauthorised persons off the Site, and (b) authorised persons shall be limited to the Contractor's Personnel and the Employer's Personnel; and to any other personnel notified to the Contractor, by the Employer or the Engineer, as authorised personnel of the Employer's other contractors on the Site.
New Clause-4.41	<p>Contractor's Operations on Site</p> <p>The Contractor shall confine his operations to the Site, and to any additional areas which may be obtained by the Contractor and agreed by the Engineer as working areas. The Contractor shall take all necessary precautions to keep Contractor's Equipment and Contractor's Personnel within the Site and these additional areas, and to keep them off adjacent land.</p> <p>During the execution of the Works, the Contractor shall keep the Site free from all unnecessary obstruction, and shall store or dispose of any Contractor's Equipment or surplus materials. The Contractor shall clear away and remove from the Site any wreckage, rubbish and Temporary Works which are no longer required.</p> <p>Upon the issue of a Taking-Over Certificate, the Contractor shall clear away and remove, from that part of the Site and Works to which the Taking-Over Certificate refers, all Contractor's Equipment, surplus material, wreckage, rubbish and Temporary Works. The Contractor shall leave that part of the Site and the Works in a clean and safe condition.</p> <p>However, the Contractor may retain on Site, during the Defects Notification Period, such Goods as are required for the Contractor to fulfill obligations under the Contract.</p>
New Clause-4.42	<p>Design – General Obligations:</p> <p>Drawings for Permanent works:</p> <p>Preliminary Drawings showing general dimensions & details elaborating the scope of work (not</p>

	<p>based on detailed design) will be supplied along with the Tender documents.</p> <p>Design, Drawings and Specifications:</p> <p>The Contractor shall Design the false work, form work, staging scheme etc. required to perform their work and shall get the same and related working drawings approved by the Engineer. The Contractor would supply 6 sets of these drawings to the Engineer for the latter's use.</p> <p>Shop Drawings</p> <p>Based on "Good for Construction "drawings issued by Engineer the Contractor shall prepare shop / fabrication drawings to scale as directed indicating the required details. The shop drawings shall be prepared before execution of work, after taking actual site dimensions and all existing and proposed services / structures etc. The shop / fabrication drawings shall be checked by independent consultant prior to submission to the Engineer for approval.</p> <p>Shop drawings submitted by the Contractor shall be in sufficient detail to indicate the type, size, arrangement, breakdown for packing and shipment, the external connections, fixing arrangements required, the dimensions required for installation and interconnections with other equipment and materials, clearances and spaces required between various portions and any other information specifically called for.</p> <p>Approval of Engineer of any such proposal / drawings shall not relieve the contractor of his responsibility of sufficiency of such works. It shall be the responsibility of the Contractor to promptly bring to the notice of the Engineer any error or discrepancy in the Contract documents and obtains his orders thereon. Only stated dimensions are to be taken and not those obtained from scaling drawings. In case any feature of the work is not fully described and set forth in the Drawings and Specifications, the Contractor shall forthwith apply to the Engineer for further instructions, Drawings or Specifications.</p>
New Clause-4.43	<p>Fossils</p> <p>All fossils, coins, articles of value or antiquity, and structures and other remains or items of geological or archaeological interest found on the Site shall be placed under the care and authority of the Employer. The Contractor shall take reasonable precautions to prevent Contractor's Personnel or other persons from removing or damaging any of these findings.</p> <p>The Contractor shall, upon discovery of any such finding, promptly give notice to the Engineer, who shall issue instructions for dealing with it. If the Contractor suffers delay and/or incurs Cost from complying with the instructions, the Contractor shall give a further notice to the Engineer and shall be entitled subject to Sub-Clause 4.1/SCC [Contractor's Claims] to:</p> <p>(a) an extension of time for any such delay, if completion is or will be delayed, under Sub-Clause 26.5/PCC [Extension of Time for Completion], and</p> <p>(b) payment of any such Cost, which shall be included in the Contract Price.</p> <p>After receiving this further notice, the Engineer shall proceed in accordance with New-Clause 3.5/PCC [Determinations] to agree or determine these matters.</p>
	<p>5. PLANT, MATERIALS AND WORKMANSHIP.</p>
New Clause-5.1	<p>Manner of Execution</p> <p>The Contractor shall carry out the manufacture of Plant, the production and manufacture of Materials, and all other execution of the Works:</p> <p>(a) in the manner (if any) specified in the Contract,</p>

	<p>(b) in a proper workmanlike and careful manner, in accordance with recognised good practice, and</p> <p>(c) with properly equipped facilities and non-hazardous Materials, except as otherwise specified in the Contract.</p>
New Clause-5.2	<p>Samples</p> <p>The Contractor shall submit the following samples of Materials, and relevant information, to the Engineer for consent prior to using the Materials in or for the Works:</p> <p>(a) manufacturer's standard samples of Materials and samples specified in the Contract, all at the Contractor's cost, and</p> <p>(b) additional samples instructed by the Engineer as a Variation.</p> <p>Each sample shall be labelled as to origin and intended use in the Works.</p>
New Clause-5.3	<p>Inspection</p> <p>The Employer's Personnel shall at all reasonable times:</p> <p>(a) have full access to all parts of the Site and to all places from which natural Materials are being obtained, and</p> <p>(b) during production, manufacture and construction (at the Site and elsewhere), be entitled to examine, inspect, measure and test the materials and workmanship, and to check the progress of manufacture of Plant and production and manufacture of Materials.</p> <p>The Contractor shall give the Employer's Personnel full opportunity to carry out these activities, including providing access, facilities, permissions and safety equipment. No such activity shall relieve the Contractor from any obligation or responsibility.</p> <p>The Contractor shall give notice to the Engineer whenever any work is ready and before it is covered up, put out of sight, or packaged for storage or transport. The Engineer shall then either carry out the examination, inspection, measurement or testing without unreasonable delay, or promptly give notice to the Contractor that the Engineer does not require to do so. If the Contractor fails to give the notice, he shall, if and when required by the Engineer, uncover the work and thereafter reinstate and make good, all at the Contractor's cost.</p>
New Clause-5.4	<p>Testing</p> <p>This Sub-Clause shall apply to all tests specified in the Contract, other than the Tests after Completion (if any).</p> <p>The Contractor shall provide all apparatus, assistance, documents and other information, electricity, equipment, fuel, consumables, instruments, labour, materials, and suitably qualified and experienced staff, as are necessary to carry out the specified tests efficiently. The Contractor shall agree, with the Engineer, the time and place for the specified testing of any Plant, Materials and other parts of the Works.</p> <p>The Engineer may, under Clause 34/PCC [Variations and Adjustments], vary the location or details of specified tests, or instruct the Contractor to carry out additional tests. If these varied or additional tests show that the tested Plant, Materials or workmanship is not in accordance with the Contract, the cost of carrying out this Variation shall be borne by the Contractor, notwithstanding other provisions of the Contract.</p>

	<p>The Engineer shall give the Contractor not less than 24 hours' notice of the Engineer's intention to attend the tests. If the Engineer does not attend at the time and place agreed, the Contractor may proceed with the tests, unless otherwise instructed by the Engineer, and the tests shall then be deemed to have been made in the Engineer's presence.</p> <p>If the Contractor suffers delay and/or incurs Cost from complying with these instructions or as a result of a delay for which the Employer is responsible, the Contractor shall give notice to the Engineer and shall be entitled subject to Sub-Clause 4.1/SCC [Contractor's Claims] to:</p> <ul style="list-style-type: none"> (a) an extension of time for any such delay, if completion is or will be delayed, under Sub-Clause 26.5/PCC [Extension of Time for Completion], and (b) payment of any such Cost, which shall be included in the Contract Price. <p>After receiving this notice, the Engineer shall proceed in accordance with New--Clause 3.5/PCC [Determinations] to agree or determine these matters.</p> <p>The Contractor shall promptly forward to the Engineer duly certified reports of the tests. When the specified tests have been passed, the Engineer shall endorse the Contractor's test certificate, or issue a certificate to him, to that effect. If the Engineer has not attended the tests, he shall be deemed to have accepted the readings as accurate.</p>
New Clause-5.5	<p>Rejection</p> <p>If, as a result of an examination, inspection, measurement or testing, any Plant, Materials or workmanship is found to be defective or otherwise not in accordance with the Contract, the Engineer may reject the Plant, Materials or workmanship by giving notice to the Contractor, with reasons. The Contractor shall then promptly make good the defect and ensure that the rejected item complies with the Contract.</p> <p>If the Engineer requires this Plant, Materials or workmanship to be retested, the tests shall be repeated under the same terms and conditions. If the rejection and retesting cause the Employer to incur additional costs, the Contractor shall subject to New-Clause 2.4/PCC [Employer's Claims] pay these costs to the Employer.</p>
New Clause-5.6	<p>Remedial Work</p> <p>Notwithstanding any previous test or certification, the Engineer may instruct the Contractor to:</p> <ul style="list-style-type: none"> (a) remove from the Site and replace any Plant or Materials which is not in accordance with the Contract, (b) remove and re-execute any other work which is not in accordance with the Contract, and (c) Execute any work which is urgently required for the safety of the Works, whether because of an accident, unforeseeable event or otherwise. <p>The Contractor shall comply with the instruction within a reasonable time, which shall be the time (if any) specified in the instruction, or immediately if urgency is specified under sub-paragraph (c).</p> <p>If the Contractor fails to comply with the instruction, the Employer shall be entitled to employ and pay other persons to carry out the work. Except to the extent that the Contractor would have been entitled to payment for the work, the Contractor shall subject to New-Clause 2.4/PCC [Employer's Claims] pay to the Employer all costs arising from this failure.</p>
New Clause-5.7	<p>Ownership of Plant and Materials</p>

	<p>Each item of Plant and Materials shall, to the extent consistent with the Laws of the Country, become the property of the Employer at whichever is the earlier of the following times, free from liens and other encumbrances:</p> <ul style="list-style-type: none"> (i) when it is delivered to the Site; (ii) when the Contractor is entitled to payment of the value of the Plant and Materials under Sub-Clause 26.11/PCC [Payment for Plant and Materials in Event of Suspension]. <p>Unless otherwise stated in the Specification, the Contractor shall pay all royalties, rents and other payments for:</p> <ul style="list-style-type: none"> a) natural Materials obtained from outside the Site, and b) the disposal of material from demolitions and excavations and of other surplus material (whether natural or man-made), except to the extent that disposal areas within the Site are specified in the Contract.
	6. Defect Liability
New Clause-6.1	<p>Completion of Outstanding Work and Remedying Defects</p> <p>In order that the Works and Contractor's Documents, and each Section, shall be in the condition required by the Contract (fair wear and tear excepted) by the expiry date of the relevant Defects Notification Period or as soon as practicable thereafter, the Contractor shall:</p> <ul style="list-style-type: none"> (a) complete any work which is outstanding on the date stated in a Taking-Over Certificate, within such reasonable time as is instructed by the Engineer, and (b) execute all work required to remedy defects or damage, as may be notified by (or on behalf of) the Employer on or before the expiry date of the Defects Notification Period for the Works or Section (as the case may be). <p>If a defect appears or damage occurs, the Contractor shall be notified accordingly, by (or on behalf of) the Employer.</p>
New Clause-6.2	<p>Cost of Remedying Defects</p> <p>All work referred to in sub-paragraph (b) of New-Clause 6.1/PCC [Completion of Outstanding Work and Remedying Defects] shall be executed at the risk and cost of the Contractor, if and to the extent that the work is attributable to:</p> <ul style="list-style-type: none"> (a) any design for which the Contractor is responsible, (b) Plant, Materials or workmanship not being in accordance with the Contract, or (c) failure by the Contractor to comply with any other obligation. <p>If and to the extent that such work is attributable to any other cause, the Contractor shall be notified promptly by (or on behalf of) the Employer, and Sub-Clause 34.1/PCC [Variation Procedure] shall apply</p>
New Clause-6.3	<p>Extension of Defects Notification Period</p> <p>The Employer shall be entitled subject to New-Clause 2.4/PCC [Employer's Claims] to an extension of the Defects Notification Period for the Works or a Section if and to the extent that the Works, Section or a major item of Plant (as the case may be, and after taking over) cannot be used for the purposes for which they are intended by reason of a defect or damage. However, a Defects Notification Period shall not be extended by more than two years.</p>

	<p>If delivery and/or erection of Plant and/or Materials was suspended under Sub-Clause 26.9/PCC [Suspension of Work] the Contractor's obligations under this Clause shall not apply to any defects or damage occurring more than two years after the Defects Notification Period for the Plant and/or Materials would otherwise have expired.</p>
New Clause-6.4	<p>Failure to Remedy Defects</p> <p>If the Contractor fails to remedy any defect or damage within a reasonable time, a date may be fixed by (or on behalf of) the Employer, on or by which the defect or damage is to be remedied. The Contractor shall be given reasonable notice of this date.</p> <p>If the Contractor fails to remedy the defect or damage by this notified date and this remedial work was to be executed at the cost of the Contractor under New-Clause 6.2/PCC [Cost of Remedying Defects], the Employer may (at his option):</p> <ul style="list-style-type: none"> (a) Carry out the work himself or by others, in a reasonable manner and at the Contractor's cost, but the Contractor shall have no responsibility for this work; and the Contractor shall subject to New-Clause 2.4/PCC [Employer's Claims] pay to the Employer the costs reasonably incurred by the Employer in remedying the defect or damage; (b) require the Engineer to agree or determine a reasonable reduction in the Contract Price in accordance with New-Clause 3.5/PCC [Determinations]; or (c) if the defect or damage deprives the Employer of substantially the whole benefit of the Works or any major part of the Works, terminate the Contract as a whole, or in respect of such major part which cannot be put to the intended use. Without prejudice to any other rights, under the Contract or otherwise, the Employer shall then be entitled to recover all sums paid for the Works or for such part (as the case may be), plus financing costs and the cost of dismantling the same, clearing the Site and returning Plant and Materials to the Contractor.
New Clause-6.5	<p>Removal of Defective Work</p> <p>If the defect or damage cannot be remedied expeditiously on the Site and the Employer gives consent, the Contractor may remove from the Site for the purposes of repair such items of Plant as are defective or damaged. This consent may require the Contractor to increase the amount of the Performance Security by the full replacement cost of these items, or to provide other appropriate security.</p>
New Clause-6.6	<p>Further Tests</p> <p>If the work of remedying of any defect or damage may affect the performance of the Works, the Engineer may require the repetition of any of the tests described in the Contract. The requirement shall be made by notice within 28 days after the defect or damage is remedied.</p> <p>These tests shall be carried out in accordance with the terms applicable to the previous tests, except that they shall be carried out at the risk and cost of the Party liable, under New-Clause 6.2/PCC [Cost of Remedying Defects], for the cost of the remedial work.</p>
New Clause-6.7	<p>Right of Access</p>

	<p>Until the Performance Certificate has been issued, the Contractor shall have such right of access to the Works as is reasonably required in order to comply with this Clause, except as may be inconsistent with the Employer's reasonable security restrictions.</p>
New Clause-6.8	<p>Contractor to Search</p> <p>The Contractor shall, if required by the Engineer, search for the cause of any defect, under the direction of the Engineer. Unless the defect is to be remedied at the cost of the Contractor under New-Clause 6.2/PCC [Cost of Remedying Defects], the Cost of the search shall be agreed or determined by the Engineer in accordance with New-Clause 3.5/PCC [Determinations] and shall be included in the Contract Price.</p>
New Clause-6.9	<p>Performance Certificate</p> <p>Performance of the Contractor's obligations shall not be considered to have been completed until the Employer has issued the Performance Certificate to the Contractor, stating the date on which the Contractor completed his obligations under the Contract.</p> <p>The Employer shall issue the Performance Certificate within 28 days after the latest of the expiry dates of the Defects Notification Periods, or as soon thereafter as the Contractor has supplied all the Contractor's Documents and completed and tested all the Works, including remedying any defects.</p> <p>Only the Performance Certificate shall be deemed to constitute acceptance of the Works.</p>
New Clause-6.10	<p>Unfulfilled Obligations</p> <p>After the Performance Certificate has been issued, each Party shall remain liable for the fulfilment of any obligation which remains unperformed at that time. For the purposes of determining the nature and extent of unperformed obligations, the Contract shall be deemed to remain in force.</p> <p>Emergency defect rectification</p> <p>If any defect or damage is one requiring immediate attention from safety, environmental or operational viewpoint, the Engineer has the authority to proceed with rectification in any manner suitable and deduct such sums from the Contract Price</p>
New Clause-6.11	<p>Clearance of Site</p> <p>Upon receiving the Performance Certificate, the Contractor shall remove any remaining Contractor's Equipment, surplus material, wreckage, rubbish and Temporary Works from the Site.</p> <p>If all these items have not been removed within 28 days after the Employer receives a copy of the Performance Certificate, the Employer may sell or otherwise dispose of any remaining items. The Employer shall be entitled to be paid the costs incurred in connection with, or attributable to, such sale or disposal and restoring the Site.</p> <p>Any balance of the moneys from the sale shall be paid to the Contractor. If these moneys are less than the Employer's costs, the Contractor shall pay the outstanding balance to the Employer.</p>
	7.MEASURMENT AND EVALUATION
New Clause 7.1	<p>Works to be Measured</p> <p>The Works shall be measured, and valued for payment, in accordance with this Clause.</p> <p>Whenever the Engineer requires any part of the Works to be measured, reasonable notice shall be given to the Contractor's Representative, who shall:</p>

	<p>(a) promptly either attend or send another qualified representative to assist the Engineer in making the measurement, and</p> <p>(b) supply any particulars requested by the Engineer.</p> <p>If the Contractor fails to attend or send a representative, the measurement made by (or on behalf of) the Engineer shall be accepted as accurate.</p> <p>Except as otherwise stated in the Contract, wherever any Permanent Works are to be measured from records, these shall be prepared by the Engineer. The Contractor shall, as and when requested, attend to examine and agree the records with the Engineer, and shall sign the same when agreed. If the Contractor does not attend, the records shall be accepted as accurate.</p> <p>If the Contractor examines and disagrees the records, and/or does not sign them as agreed, then the Contractor shall give notice to the Engineer of the respects in which the records are asserted to be inaccurate. After receiving this notice, the Engineer shall review the records and either confirm or vary them. If the Contractor does not so give notice to the Engineer within 14 days after being requested to examine the records, they shall be accepted as accurate.</p>
New Clause 7.2	<p>Method of Measurement</p> <p>Except as otherwise stated in the Contract and notwithstanding local practice:</p> <p>(a) measurement shall be made of the net actual quantity of each item of the Permanent Works, and</p> <p>(b) the method of measurement shall be in accordance with the Bill of Quantities or other applicable Schedules.</p>
New Clause 7.3	<p>Omissions</p> <p>Whenever the omission of any work form's part (or all) of a Variation, the value of which has not been agreed, if:</p> <p>a) the Contractor will incur (or has incurred) cost which, if the work had not been omitted, would have been deemed to be covered by a sum forming part of the Accepted Contract Amount;</p> <p>b) the omission of the work will result (or has resulted) in this sum not forming part of the Contract Price; and</p> <p>c) this cost is not deemed to be included in the evaluation of any substituted work;</p> <p>then the Contractor shall give notice to the Engineer accordingly, with supporting particulars. Upon receiving this notice, the Engineer shall proceed in accordance with New-Clause 3.5/PCC [Determinations] to agree or determine this cost, which shall be included in the Contract Price.</p>
New Clause 8	<p>FORCE MAJEURE</p> <p>If at any time, during the continuance of this contract, the performance in whole or in part by either party of any obligation under this contract shall be prevented or delayed by reason of any war, hostility, acts of public enemy, civil commotion, sabotage, serious loss or damage by fire, explosions, epidemics, pandemics, strikes, lockouts or acts of God (hereinafter referred to 'events') provided, notice of the happening of any such event is given by either party to the other within 14 days from the date of occurrence thereof, neither party shall by reason of such event, be entitled to terminate this contract nor shall either party have any claim for damages against the other in respect of such non-performance or delay in performance, and works under the contract shall be resumed as soon as practicable after such event has come to an end or ceased</p>

	<p>to exist, and decision of the Engineer as to whether the works have been so resumed or not shall be final and conclusive, PROVIDED FURTHER that if the performance in whole or in part of any obligation under this contract is prevented or delayed by reason of any such event for a continuous period exceeding 84 days, either party may at its option terminate the contract by giving notice to the other party.</p> <p>Payment and Release in case of Optional Termination</p> <p>Upon such termination, the Engineer shall determine the value of the work done and issue a Payment Certificate which shall include:</p> <ol style="list-style-type: none"> a) The amounts payable for any work carried out for which a price is stated in the contract; b) The Cost of Plant and Materials ordered for the Works which have been delivered to the Contractor, or of which the contractor is liable to accept delivery; this Plant and materials shall become the property of (and be at the risk of) the Employer when paid for by the Employer, the Contractor shall place the same at the Employer's disposal; c) Other Costs or liabilities supported by necessary documentary evidence which in the circumstances were reasonably and necessarily incurred by the Contractor in the expectation of completing the Works as per mutually agreed programme. d) the Cost of removal of Temporary Works and Contractor's Equipment from the Site and the return of these items to the Contractor's works in his country (or to any other destination at no greater cost).
New Clause-9	Defect liability period: 365 Days
New Clause-10	<p>Integrated testing and system commissioning</p> <p>Integrated Testing: Tests on Completion shall also include Integrated Testing. The Contractor shall, following satisfactory completion of tests on his works, equipment, sub-systems or system, perform, at the direction of the Engineer, programme of tests to verify and confirm the compatibility and complete performance of his works, equipment, sub-systems or system with the works, equipment, sub-systems or system provided by others.</p> <p>Compilation of Test Results: The results of the Integrated Testing and Commissioning shall be compiled and evaluated by the Engineer and the Contractor</p> <p>Retesting: If the Works, or a part thereof, or a Section, fail to pass the Integrated Testing and Commissioning, the Engineer may order such failed tests to be repeated with the same terms and conditions. If such failure and retesting result from a default of the Contractor and cause the Employer to incur costs, the same shall be recoverable from the Contractor by the Employer, and may be deducted by the Employer from any amount due, or to become due, to the Contractor.</p> <p>Failure to Pass Test: If the Works, or a part thereof, or a Section, fail to pass Integrated Testing and Commissioning and the Contractor in consequence proposes to make any adjustment or modification to the Works or a part thereof, or a section, the Engineer may, with the approval of the Employer, instruct the Contractor to carry out such adjustment or modification, at his own cost and to satisfy the requirements of Integrated Testing and Commissioning within such time as the Employer / Engineer may deem to be reasonable.</p>

	<p>Statutory Requirements: The Contractor shall carry out all statutory tests and trials, under the supervision of the Engineer, necessary for obtaining sanction of the competent authority for opening the system for public carriage of passengers as mentioned in the Special Conditions of Contract.</p>
New clause-11	<p>Conflict of Interest:</p> <p>The Contractor shall carry out all statutory tests and trials, under the supervision of the Engineer, necessary for obtaining sanction of the competent authority for opening the system for public carriage of passengers as mentioned in the Special Conditions of Contract.</p> <p>Conflict of Interest The remuneration of the Tenderer shall constitute the Tenderer's sole remuneration in connection with this Contract or the Services and, the Tenderers shall not accept for their own benefit any trade commission, discount or similar payment in connection with activities pursuant to this Contract or to the Services or in the discharge of their obligations hereunder, and the Tenderers shall use their best efforts to ensure that any Personnel either of them, similarly shall not receive any such additional remuneration Neither the Tenderer nor the Personnel of either of them shall engage, either directly or indirectly, in any of the following activities:</p> <p>(a) during the term of this Contract, any business or professional activities in India which would conflict with the activities assigned to them under this Contract</p> <p>The tenderer shall not be one of the following:</p> <p>(i) A firm which has been engaged by the Employer to provide consulting services for the preparation related to procurement for or implementation of this project.</p> <p>(ii) Any association/affiliation (inclusive of parent firms) of a firm or an organization mentioned in para (i) above.</p> <p>(iii) A Tenderer who lends, or temporarily seconds its personnel to firms or organizations which were engaged in consulting services for the preparation related to procurement for or implementation of the project, if the personnel would be involved in any capacity on the same project.</p> <p>Jurisdiction of Court in case of dispute or differences arising on account of this tender: Any suit or application, arising out of any dispute or differences on account of this tender shall be filed in a competent court at Bangalore, Karnataka only and no other court or any other district of the country shall have any jurisdiction in the matter.</p>
New Clause-12	<p>Special/Acceleration Advance</p> <p>Employer at his sole discretion, may provide Interest bearing Special/Acceleration Advance based on the recommendation of the Engineer to expedite works or to bring forward the completion date(s) and on account of immediate additional mobilisation to complete balance works as targeted. The maximum cumulative Special/Acceleration Advance shall be 10% of the Accepted contract amount, which shall be released in stages as and when deemed appropriate as decided by the Engineer/Employer. The advance released at a time shall not exceed 2.5% of the Accepted contract amount.</p>
New Clause-13	DELETED
New Clause-14	Ruling Language- English

New Clause-15	Language for communications- English
New Clause-16	Time for access to Site (After the date of commencement) Starting from the Date of Commencement, the section will be progressively handed over in 180 days.
New clause-17	Employers' Bank details for Letter of Credit (a) Nodal Branch Canara Bank, MG Road, Bangalore 560001 IFSC Code – CNRB0002636 A/c No - 0430201012110 (b) Issuance/ reimbursing branch for LC Shall be indicated later.

APPENDIX 1

SALIENT FEATURES OF SOME MAJOR LABOUR LAWS APPLICABLE TO ESTABLISHMENTS ENGAGED IN BUILDING AND OTHER CONSTRUCTION WORK

(The laws as current on the date of bid opening will apply)

- a) **Employees Compensation Act 1923:** The Act provides for compensation in case of injury by accident arising out of and during the course of employment.
- b) **Payment of Gratuity Act 1972:** Gratuity is payable to an employee under the Act on satisfaction of certain conditions on separation if an employee has completed 5 years service or more or on death the rate of 15 days wages for every completed year of service. The Act is applicable to all establishments employing 10 or more employees.
- c) **Employees Provident Fund and Miscellaneous Provisions Act 1952 (since amended):** The Act Provides for monthly contributions by the employer plus workers @ 10% or 8.33%. The benefits payable under the Act are:
 - (i) Pension or family pension on retirement or death, as the case may be.
 - (ii) Deposit linked insurance on the death in harness of the worker.
 - (iii) payment of P.F. accumulation on retirement/death etc.
- d) **Maternity Benefit Act 1951:** The Act provides for leave and some other benefits to women employees in case of confinement or miscarriage etc.
- e) **Contract Labour (Regulation & Abolition) Act 1970:** The Act provides for certain welfare measures to be provided by the Contractor to contract labour and in case the Contractor fails to provide, the same are required to be provided, by the Principal Employer by Law. The Principal

Employer is required to take Certificate of Registration and the Contractor is required to take license from the designated Officer. The Act is applicable to the establishments or Contractor of Principal Employer if they employ 20 or more contract labour.

- f) **Minimum Wages Act 1948:** The Employer is supposed to pay not less than the Minimum Wages fixed by appropriate Government as per provisions of the Act if the employment is a scheduled employment. Construction of Buildings, Roads, Runways are scheduled employments.
- g) **Payment of Wages Act 1936:** It lays down as to by what date the wages are to be paid, when it will be paid and what deductions can be made from the wages of the workers.
- h) **Equal Remuneration Act 1979:** The Act provides for payment of equal wages for work of equal nature to Male and Female workers and for not making discrimination against Female employees in the matters of transfers, training and promotions etc.
- i) **Payment of Bonus Act 1965:** The Act is applicable to all establishments employing 20 or more employees. The Act provides for payments of annual bonus subject to a minimum of 8.33% of wages and maximum of 20% of wages to employees drawing Rs.7000/-per month or the minimum wage as fixed by the appropriate government whichever is higher. The Act does not apply to certain establishments. The newly set-up establishments are exempted for five years in certain circumstances. Some of the State Governments have reduced the employment size from 20 to 10 for the purpose of applicability of this Act.
- j) **Industrial Disputes Act 1947:** The Act lays down the machinery and procedure for resolution of Industrial disputes, in what situations a strike or lock-out becomes illegal and what are the requirements for laying off or retrenching the employees or closing down the establishment.
- k) **Industrial Employment (Standing Orders) Act 1946:** It is applicable to all establishments employing 100 or more workmen (employment size reduced by some of the States and Central Government to 50). The Act provides for laying down rules governing the conditions of employment by the Employer on matters provided in the Act and get the same certified by the designated Authority.
- l) **Trade Unions Act 1926:** The Act lays down the procedure for registration of trade unions of workmen and employers. The Trade Unions registered under the Act have been given certain immunities from civil and criminal liabilities.
- m) **Child and Adolescent Labour (Prohibition & Regulation) Act 1986:** The Act prohibits employment of children below 14 years of age in certain occupations and processes and provides for regulation of employment of children in all other occupations and processes. Employment of Child Labour is prohibited in Building and Construction Industry.
- n) **Inter-State Migrant Workmen's (Regulation of Employment & Conditions of Service) Act 1979:** The Act is applicable to an establishment which employs 5 or more inter-state migrant workmen through an intermediary (who has recruited workmen in one state for employment in the establishment situated in another state). The Inter-State migrant workmen, in an establishment to

which this Act becomes applicable, are required to be provided certain facilities such as housing, medical aid, travelling expenses from home upto the establishment and back, etc.

- o) **The Building and Other Construction Workers (Regulation of Employment and Conditions of Service) Act 1996 and the Cess Act of 1996:** All the establishments who carry on any building or other construction work and employs 10 or more workers are covered under this Act. All such establishments are required to pay cess at the rate not exceeding 2% of the cost of construction as may be modified by the Government. The Employer of the establishment is required to provide safety measures at the Building or construction work and other welfare measures, such as Canteens, First-Aid facilities, Ambulance, Housing accommodations for workers near the work place etc. The Employer to whom the Act applies has to obtain a registration certificate from the Registering Officer appointed by the Government.

As per Central Government's Notification No.S.O.2899 dated 26.09.1996 under this act, the cess shall be levied @1% of cost of construction works which shall be deducted from each bill of the payment due to the contractor.

- p) **Factories Act 1948:** The Act lays down the procedure for approval at plans before setting up a factory, health and safety provisions, welfare provisions, working hours, annual earned leave and rendering information regarding accidents or dangerous occurrences to designated authorities. It is applicable to premises employing 10 persons or more with aid of power or 20 or more persons without the aid of power engaged in manufacturing process.
- q) **The Employees State Insurance Act, 1948 (Act No. 34 of 1948) (Provisions as extended from time to time):**An Act to provide for certain benefits to employees in case of sickness, maternity and 'employment injury' and to make provision for certain other matters in relation thereto.

--00--00--00--

Section 5	Works/Employers Requirements
------------------	-------------------------------------

This Section contains the specifications, the safety precautions and supplementary information that describe the Work to be executed.

INDEX

	Description	Pages
1	Safety and Security	238-249
2	General Information and Scope of work	250-258
3	Site Facilities for the Employer and the Engineer	258-259
4	Specifications	260
5	Personnel	261-262
6	Equipment	262-263

Safety and Security at work

1.1 The works included in this contract are to be carried out close to the running tracks and public utilities, therefore, safety of running trains and the public is paramount. Therefore, all activities undertaken by the Contractor/his Sub-contractors shall ensure safety at all times. The contractor shall comply with the instructions issued by the Railway/ Engineer/Employer from time to time to ensure safe running of trains while carrying out works. The rates quoted by the Contractor shall be deemed to include all expenditure incurred in compliance with the same.

1.2 Before starting any excavation work adjacent to existing track, the contractor shall ensure that necessary permissions has been obtained and required precautions have been taken for doing such work in terms Joint Procedure Order (JPO). The penalties mentioned in the following JPO shall be levied on the contractor if such event occur. The JPO is reproduced below:

“JOINT PROCEDURE ORDER FOR UNDERTAKING DIGGING WORK IN THE VICINITY OF UNDERGROUND SIGNALING, ELECTRICAL AND TELECOMMUNICATION CABLES”

A) A number of Engineering works in connection with gauge conversion/doubling/third line are in progress on various railways, which require extensive digging work near the running track, in close vicinity of the working S&T cables carrying vital safety circuits as well as electrical cables feeding the power supply to cabins. ASM room, RRI Cabin, Intermediate Block Huts (IBH) etc. Similarly, S&T organization under open line or construction units under CAO/C, are executing various Signaling and Telecom works requiring digging of earth for laying of cables or casting of foundations for the erection of signal posts etc. RailTel is also executing the work of laying of quad cable and OFC on various Railways as a part of sanctioned works for exclusive use of Railways for carrying voice and data i.e. administrative and control communication, PRS, FOIS etc. or shared by RailTel Corporation of India Ltd. On certain sections digging is also required for laying of electrical cable and casting of foundation for the erection of OHE masts by Electrical Dept. Generally, these works are executed by contractors employed by these organizations.

B) However, while carrying out these works in the vicinity of working signaling, telecommunication and electrical cables, at times, cable cuts take place due to JCB machines working along the track or during the digging work being done by contractors carrying out the Civil Engineering Works. Similarly, such cable cuts are also resulting due to works undertaken by S&T or Electrical departments. Such cable faults results in the failure of vital signaling and telecommunication circuits & electrical installations.

C) Henceforth, the following joint procedure shall be followed by Engineering, Electrical and S&T (and RailTel organisation, wherever such works are being done by them) officers of the respective divisions and by the construction organisation, while carrying out any digging work near to existing signaling & telecommunication and electrical cables, so that the instances of cable cut due to execution of works, can be controlled and minimized.

1. S&T Department (and RailTel, where they have laid the cables) and Electrical department shall provide a detailed cable route plan showing exact location of cable at an interval of 200m or wherever there is change in alignment so that the same is located easily by the Engineering official/contractor. In addition, S&T department and Electrical department shall also provide cable markers along the alignment of the cable. These cable route plans shall be made available to the Sr.DEN/DEN or Dy.CE/C, as the case may be, by Sr. DSTE/DSTE or Sr. DEE/DEE of the divisions or Dy.CSTE/C or Dy.CEE/C within 15 days in duplicate. Sr.DEN/DEN or Dy.CE/C will send copies to their field unit i.e. AEN/SE/P.Way & Works.
2. Before taking up any digging activity on a particular work by any agency, Sr.DSTE/DSTE or Sr.DEE/DEE of the section shall be approached in writing by the concerned Engg. or S&T or Electrical officer for permitting to undertake the work. Sr.DSTE/DSTE or Sr.DEE/DEE, after ensuring that the concerned executing agencies including the contractor have fully understood the S&T and Electrical cable route plan shall permit the work in writing within 7 days of the request by concerned department.
3. After getting the permission from S&T or Electrical department as the case may be, the relevant portion of the cable route plan shall be attached to the letter through which permission is issued to the contractor by concerned Engg. official for commencement of work and ensuring that the contractors have fully understood the cable route plan and precautions to be taken to prevent damage to the underground cables. The contractor shall be asked to study the cable plan and follow it meticulously to ensure that the safety of the cable is not endangered. Such a provision, including any penalty for default, should form part of agreement also. It is advisable that a suitable post of SSE/Sig or SSE/Tele or SSE/Electrical(TRD or G) shall be created chargeable to the estimates of doubling/gauge conversion, who can help Engg. agencies in the execution of the work. However basic responsibility will be of the department executing the work and the Contractor. Creation of posts is not mandatory.
4. The SSE/P.Way or SE/Works shall pass on the information to the concerned SSE/Sig, SSE/Tele or SSE/Electrical(TRD or G) about the works being taken up by the contractors in their sections at least 3 days in advance of the day of the work. In addition Engineering control shall also be informed by SE/P.Way or SE/Works, who in turn shall pass on the information to the test room/network operation centre of RailTel/TPC/Electrical control.
5. On receiving the above information, SSE/Sig or SSE/Tele or SSE/Electrical (TRD or G) shall visit the site on or before the date of taking up the work and issue permission to the contractor to commence the work after checking that adequate precautions have been taken to avoid the damage to the cables. The permission shall be granted within 3 days of submission of such requests.

6. The name of the contractor, his contact telephone number, the nature of the work shall be notified in the Engineering control as soon as the concerned Engineering officials issue the letter authorizing commencement of work to the contractor. Test room shall be given copies. Test room shall collect any further details from the Engineering Control and shall pass it on to S&T/RailTel & Electrical officials regularly. In case the supervisors of concerned departments do not turn up on the day as advised in terms of para 4 and 5 above, the works of contractor should not be stopped on this account.
7. In case of works being taken up by the State Government, National Highway Authority etc., the details of the permission given i.e. the nature the work, kilometer etc. be given to the Engineering control including the contact person's number so that the work can be done in a planned manner. The permission letter shall indicate the contact numbers of Test room/network Operating Centre of RailTel/TPC/Elect. Control.
8. Where the nature of the work taken up by the Engineering department is such that the OFC or other S&T cables or Electrical cables is to be shifted and relocated, notice of minimum one week shall be given so that the Division/RailTel/Construction can plan the works properly for shifting. Such shifting works shall in addition, for security and integrity of the cables, be supervised by S&T supervisors/RailTel supervisors/Electrical Supervisors.
9. The concerned SSE/P. Way/SSE/Works/SSE/Sig/SSE/Tele/SSE/Electrical (TRD or G) or RailTel supervisors supervising the work of the contractor shall ensure that the existing emergency sockets are not damaged in view of their importance in providing communication during accident/emergency.
10. In case of minor nature of works where shifting of cable is not required, in order to prevent damage to the cable, the Engineering contractor shall take out the S&T or optical fibre cable or Electrical cable carefully from the trench and place it properly alongside at a safe location before starting the earthwork under the supervision of SSE/Sig or SSE/Tele or SSE/Electrical(TRD or G). The cable shall be reburied soon after completion of excavation with proper care including placement of the brick over the cable under the supervision of S&T or Electrical supervisors. However, the work will be charged to the concerned engineering works. The responsibility for ensuring availability of SSE (Signal), SSE (Electrical) as per para 4 and 5 above lies with the respective department. The contractor will go ahead with the shifting of cables as per the program decided and he will not be held responsible for any cable cut.
11. In all the sections where major project are to be taken up/going on RailTel/S&T department shall deploy their official to take preventive/corrective action at site of work. As regards Electrical Department, the official may be deputed on need basis.

12. No new OFC or quad cable shall be laid close to existing track. It shall be laid close to the Railway boundary on one side of the Railway track to the extent possible to avoid any interference with the future works (doubling etc.). It shall be ensured in the new works of cable laying that the cable route is properly identified with electronic or concrete markers. Wherever multiple cables are laid in a trench, RFID markers may be provided for easy identification of the cable. Henceforth, wherever cable laying is planned, before undertaking the cable laying work, the cable route plan of the same shall be prepared by the Dy. CSTE/A or Dy. CEE/C and shall be got approved from the concerned Sr. DSTE/DSTE or Sr.DEE/DEE and also from the concerned Dy. CE/C for new lines and from the concerned Sr.DEN for all other projects including GC etc., to avoid possible damages in future. Such approvals shall be granted within 15 days of the submission of the request.
13. The works of excavating the trench and laying of the cable should proceed in quick succession, leaving a minimum time between the two activities.
14. In case damage caused to OFC/Quad cable or Electrical cable during execution of the work, the contractor is liable to pay a penalty for damaging the cable. Penalty shall not be levied in case of the following:-
- i). Detailed cable route plan as per clause C-1 not provided by concerned department or cable is not protected as per laid down procedures.
 - ii). The alignment of the cable does not tally with the information provided to the contractor.
 - iii). The cable depth is found to be less than 800 mm from normal ground level.
 - iv). No representative of S&T department/RailTel was available at site guarding the cables on the fixed pre determined date and time.
15. Penalty to be imposed for damages to cable shall be as under:-

Cable damaged	Penalty per location
Only Quad cable or Signalling cable	Rs.1.0 Lakh
Only OFC	Rs.1.25 Lakh
Both OFC & Quad	Rs.1.5 Lakh
Electrical Cable	Rs.1.0 Lakh

Necessary debit in this regard shall be raised on the department undertaking the work who shall in turn levy the penalty on the defaulting contractor. S&T department shall raise the debits in case of damage to OFC or Quad or Signaling cable and Electrical department shall raise the debits in case of damage to Electrical cable.

16. Railways will not lodge FIR with RPF in case of works being executed by authorized contractors of Railways who have been duly permitted to execute the works in accordance with this JPO. Joint note by the supervisors of the concerned department shall be prepared and the responsibility of the cable cut should be decided without involving RPF. The joint note deciding the fact whether the contractor should be penalized shall be completed in a day's time from the occurrence of cable cut.

In all other cases, when the cable is cut by an agency that was not permitted to execute any work, FIR should be lodged with RPF.
17. While giving permission for taking up the works, concerned departments may note that earthwork by engineering contractors will normally be done by machines except in a few isolated locations where the quantity of earth work is very less.
18. Railways shall make necessary correction in their future contract so that this JPO can also be enforced contractually.
19. In case of damages to OFC, RailTel should be paid 5/6th of the penalty recovered. RailTel shall raise demands on the S&T department in this regard.
20. All types of signaling & OHE bonds i.e. rail bond, cross bond and structure bond shall be restored by the contractor with a view to keep rail voltage low to ensure safety of personnel.
21. Above joint circular shall be applicable for construction as well as open line organization of Engineering, S&T and Electrical.
22. S&T cable and electrical cable route plan should be prepared by the concerned S&T and Electrical officers respectively and got approved as stipulated in para C-12 before undertaking the work. The completion cable route plan should be finalized block section by block section as soon as the work is completed.
23. All cable laying works shall be executed as per laid down technical specifications, such as protection measures/protective cover, compaction of refilled material etc.

1.3. Working near running line

- 1.3.1 The contractor shall not allow any road vehicle belonging to him or his suppliers etc. to ply in railway land next to the running line. If for execution of certain works viz. earth work for parallel railway line and supply of ballast for new or existing rail line, gauge conversion etc, road vehicles are necessary to be used in railway land next to the railway line, the contractor shall apply to the Engineer for permission giving the type & no. of individual vehicles, names & license particulars of the drivers, location, duration & timings for such work/movement. The Railways/Employer/ Engineer or his authorized representative will personally counsel, examine & certify, the road vehicle drivers, contractor's flag men & supervisor and will give written permission giving names of road vehicle drivers, contractor's flag men and supervisor to be deployed on the work, location, period and timing of the work. This

permission will be subject to the following obligatory conditions:

- 1.3.2 Road vehicles can ply along the track after suitable cordoning of track with minimum distance of 6 meters from the centre of the nearest track. For working of machinery close to the running tracks or plying of road vehicles during night hours, the contractor shall apply to the Engineer in writing for permission, duly indicating the site details in a neat sketch and safety measures proposed to be taken. Subject to the approval of concerned Railway authorities, the Engineer or his authorized representative will communicate permission to the contractor/contractor's representative. The contractor and his men shall strictly adhere to the instructions given along with such permissions.
- 1.3.3 Nominated vehicles and drivers shall be utilized for work in the presence of at least one flag man and one supervisor certified for such work. In order to monitor the activities during night hours, additional staff may have to be posted based on the need of the individual site.
- 1.3.4. The Contractor' machinery, equipment and vehicles shall normally operate 6 m clear of track. Any movement/work at less than 6m and upto a minimum of 3.5m clear of track centre, shall be carried out only in the presence of a person (including any railway employee) authorized by the Engineer. No part of the road vehicle shall be allowed at less than 3.5m from track centre. Cost of such railway employee shall be borne by the Employer.
- 1.3.5 The Contractor's machinery and equipment like Cranes, Flash Butt Welders, Ballasting machinery, Compactors, Track Laying Systems etc. are required to operate close to the existing line carrying traffic. Contractor is fully responsible for operating these machineries without endangering the safety of the running line and traffic

1.3.6 Safety Fencing : Deleted

- 1.4.** The contractor's special attention is drawn to Para 826 of Indian Railways Permanent Way Manual introduced under Advance Correction Slip no. 69 dated 23.05.2001, reproduced below which should invariably be complied with.

"826 Safe working of Contractors -- A large number of men and machinery are deployed by the contractors for track renewals, gauge conversions, doublings, bridge rebuilding etc. It is therefore essential that adequate safety measures are taken for safety of the trains as well as the work force. The following measures should invariably be adopted:

- (a)** The contractor shall not start any work without the presence of Railway supervisor at site.
- (b)** Wherever the road vehicles and/or machinery are required to work in the close vicinity of railway line, the work shall be so carried out that there is no infringement to the railway's schedule of dimensions. For this purpose the area where road vehicles and/or Machinery are required to ply, shall be demarcated and acknowledged by the contractor. Special care shall be taken for turning/reversal of road vehicles/machinery without infringing the running track. Barricading shall be provided wherever justified and feasible as per site conditions.

- (c)** The “look out and whistle” caution orders shall be issued to the trains and speed restrictions imposed where considered necessary. Suitable flag men/detonators shall be provided where necessary for protection of trains.
- (d)** The supervisors / workmen should be counseled about safety measures. A competency certificate to the contractor’s supervisor as per proforma annexed shall be issued by AEN which will be valid only for the work for which it has been issued.
- (e)** The unloaded ballast / rails / sleepers / other P.Way materials after unloading along track should be kept clear off moving dimensions and stacked as per the specified heights and distance from the running track.
- (f)** Supplementary site-specific instructions, wherever considered necessary, shall be issued by the Engineer.

COMPETENCY CERTIFICATE

Certified that Shri _____ supervisor Incharge of M/S _____ has been examined regarding S&T working on _____ work. His knowledge has been found satisfactory and he is capable of supervising the work safely.

ASSISTANT ENGINEER”

- 1.5.** The work of formation in banks and cuttings through out the length of doubling is adjacent to track under running traffic. Many of the bridges on the proposed double line are to be constructed either as extensions or just adjacent to the existing bridges under running traffic. The work of Installation of Track through out the length of doubling is adjacent to track under running traffic. The work of Installation of Track and Signals in the Station yards including alterations to the existing Track and Signals has to be done adjacent to or in replacement of the existing Track and Signals which are under running traffic. The contractor shall ensure that the safety of the running lines and running traffic is not endangered, because of his work.
- 1.6.** Any traffic/traction blocks, temporary speed restrictions and caution orders required in this connection shall also be got sanctioned from the Railway authorities well in advance, through the Engineer. The Railways may sanction the same for specific sites within the overall recovery time available in the Railway’s time table. The contractor shall have to schedule his programme according to the convenience of the Railways. No claim from the contractor for any delay/inconvenience/loss on this account shall be entertained by the Employer.

1.8. Ancillary and Temporary works

- (a)** The Contractor's proposals for erection of all ancillary and temporary works shall be in conformity with the proposals submitted along with the tender and modifications thereto as approved by the Engineer.
- (b)** The Contractor shall submit drawings, supporting design calculations where called for by the Engineer and other relevant details of all such works to the Engineer for approval at least one month before he desires to commence such works. Approval by the Engineer of any such proposal shall not relieve the contractor of his responsibility for the sufficiency of such works.
- (c)** The contractor shall, at his own cost, design and provide any temporary arrangements including relieving/service girders required in connection with the above said works and remove the same, when no longer required. These arrangements shall conform to Railway norms. The contractor shall obtain all necessary approvals and sanctions of the concerned Railway authorities including Commissioner of Railway Safety through the Engineer in advance and well in time.
- (f)** Notwithstanding the above, the contractor shall not, however, be relieved of his responsibility and obligation as aforesaid.
- (g)** The contractor shall bear the cost of complying with all safety requirements. No extra payment will be made for complying with the safety provisions under this chapter and the cost of all such elements to meet the safety requirements shall be deemed to be included in the Bill of Quantities

1.9. The contractor remains fully responsible for ensuring safety. In case of any accident, the Contractor shall bear cost of all damages to his equipment and men and also damages to Railway and its passengers.

1.10 Suitable barricading to forewarn road vehicle driver shall be provided by the contractor. The luminous tape, strung on bamboo or steel poles can be considered for such barricading. Barricading arrangement should be got approved by the Engineer wherever applicable.

1.11 Indemnity by Contractor

The Contractor shall indemnify and save harmless the Railway/Employer/Engineer from and against all actions, suit proceedings, losses, costs, damages, claims, and demands of every nature and description brought or recovered against the Railways/ Employer/Engineer by reason of any act or omission of the contractor, his agents or employees, in the execution of the works or in his guarding the same. All sums payable by way of compensation under any of these conditions shall be considered as reasonable compensation to be applied to the actual loss or damage sustained, and whether or not any damage shall have been sustained.

1.12. Damage to Railway Property or life or Private Property : The contractor shall be responsible for all risks to the works and for the trespass and shall make good at his own expense all loss or damage whether to the works themselves or to any other property of the Railway or the lives of persons or property of others from whatsoever cause in connection with the works until they are taken over by the Employer and this although all reasonable and proper precautions may have been taken by the Contractor, and in case the Railway/Employer/Engineer shall be called upon to make good any costs, loss or damages, or to pay any compensation, including that payable under the provisions of Workmen's compensation act or any statutory amendments thereof to any person or persons sustaining damages as aforesaid, by reason of any act, or any negligence or any omissions on the part of the contractor, the amount of any costs or charges including costs and charges in connection with legal proceedings, which the Railway/Employer/Engineer may incur in reference thereto, shall be charged to the contractor. The Railway/Employer/Engineer shall have the power and right to pay or to defend or compromise any claim of threatened legal proceedings or in anticipation of legal proceedings being instituted consequent on the action or default of the contractor, to take such steps as may be considered necessary or desirable to ward off or mitigate the effect of such proceedings, charging to Contractor, as aforesaid, any sum or sums of money which may be paid and any expenses whether for reinstatement or otherwise which may be incurred and the propriety of any such payment, defence or compromise, and the incurring of any such expense shall not be called in question by the Contractor.

1.13. Safety of Public

- (i)** The Contractor shall be responsible to take all precautions to ensure the safety of the Public whether on Public or Railway property and shall post such look out men as may in the opinion of the Engineer be required to comply with regulations pertaining to the work.
- (ii)** The Contractor shall provide effective barricading using G.I. corrugated sheets around foundation pits, trenches, erection sites, demolition sites etc., to prevent accidents and injuries to the public. He shall erect barricading duly leaving safe passage for the movement of the public as per the directions of Engineer.
- (iii)** No payment will be made for providing such barricading and the rates quoted by the Contractor shall be inclusive of such safety measures.

1.14. Reporting of Accidents

The Contractor shall report to the Engineer details of any accidents as soon as possible after its occurrence. In the case of any fatality or serious accident, the Contractor shall, in addition, notify the Engineer and the Employer immediately by the quickest available means.

1.15 Life-saving Appliances and First-aid Equipment: The Contractor shall provide and maintain upon the Works sufficient, proper and efficient life-saving appliances and first-aid equipment to the approval of the Engineer and in accordance with the requirements of ILO Convention No. 62. The appliances and equipment shall be available for use at all time

1.16 Security Measure

- (a)** Security arrangements for the work shall be in accordance with general requirements and the contractor shall conform to such requirements and shall be held responsible for the action or inaction on the part of his staff, employees and the staff and employees of his subcontractors.
- (b)** Contractor's as well as Sub Contractor's employees and representatives shall wear identification Badges (cards), uniforms, helmets, gum boots and other safety/protection gadgets/accessories provided by the Contractor. Badges shall identify the Contractor and show the employee's name and number and shall be worn at all times while at site.
- (c)** All vehicles used by the contractor shall be clearly marked with the Contractor's name or identification mark.
- (d)** The contractor shall be responsible for security of works for the duration of the contract and shall provide and maintain continuously adequate security personnel to fulfill these obligations. The requirements of security measures shall include, but not be limited to, maintenance of Law and Order at site, provision of all lighting, guard, flagmen, and all other measures necessary for protection of works within the colonies, camps and elsewhere at site, all materials delivered to the site and all persons employed in connection with the works continuously throughout working and non-working periods including nights, Sundays and holidays, for the duration of the contract. However, at work sites in close proximity of traffic corridors where public and traffic are likely to come close to the work area, suitable barricading as proposed by contractor and approved by Engineer shall be provided.
- (e)** No separate payment will be made for providing security measures and will be deemed to be included in the rates quoted by the contractor.

- 1.17 Contractor will have to comply the instructions circulated for Safety on Worksites Specially Doubling Works being implemented on Indian Railways as per relevant letters and any subsequent instructions on this issue. It is presumed that bidders have gone through the Indian Railway's policies including any subsequent instructions on this issue if any, before quoting the rates.

1.18 Ensuring Safety at work site

Ensuring safety at work site while carrying out of doubling works is of paramount importance.

Following measures must be ensured: -

1. PMC should be advised to educate his supervisor for each stretch to ensure Safety who should be well conversant safety instructions and should see that the same are not violated. PMC has to be made accountable for lapses on the safety aspects.

2. Periodical formal counseling of all contractor's staff and PMC officials regarding safety instructions and review violations coming to light and taking appropriate action.
3. Counseling of drivers and operators of machinery regarding safety aspect during routine inspection of PMC officials contractors Engineers.
4. All the drivers/machine operators should have competency certificate issued by PMC after examining their knowledge about safety. Only authorized drivers can ply within 6.6 m of the existing track will have to be proposed as found necessary.
5. Necessary caution orders to Drivers of trains wherever required in terms of Railway Board's instructions/PCE circulars.
6. In case work is required to be carried out within 3.5 M of existing running line, K RIDE should be advised well in time and requested to provide look out men and Railway Supervisors for the site. At such locations close supervision must be ensured.

In terms of contract conditions, preventing entry of outsiders at the worksites is the responsibility of contractor and this has to be ensured.

1.19 Additional Conditions to Safety at Work Spot

To ensure safety at all the work sites all the time, a dedicated Safety officer duly trained as per the provisions of the contract shall be posted by the contractor for each project. Following works will in general be assigned to safety officer.

1. The Safety officer (in charge) shall be from the permanent rolls of the contractor. He will work under the administrative control of the Project Manager of the contractor.
2. The person from any sub-contractor deputed by the main contractor shall not be designated as Safety officer.
3. The Safety officer shall be overall in charge of the safety methods being undertaken at various work sites. He shall not be given any other task related to the project planning and execution.
4. The Safety officer should be well versed with the safety aspects related to worksites in the vicinity of running railway lines and should impart training to the officials assisting him.
5. The Safety officer shall be given suitable means of transport (depending on the requirement) by the contractor to approach all the work sites frequently and ensure that adequate precautions to ensure safety have been taken. Following items shall be specifically done by the Safety officer.
 - a) Ensuring the provision of the safety fencing. Any shortfall shall be made good immediately.
 - b) Availability of suitable lookout men at each working site. The lookout men shall be in possession of hooters, safety helmet and retro-reflective jacket to

- warn the site engineer/supervisor and operators/drivers of the equipments/vehicles working near the running track.
- c) Arranging issuance of competency certificates by Employer/Engineer with the operator/driver of each equipment/vehicle before deputing for work.
 - d) Take assurance from the contractor officials at regular interval of complying with the safety instructions.
 - e) Any safety violation to be advised to all concerned and remedial action taken thereof.
6. The Safety officer will frequently counsel the contractor engineers/supervisors/ operators/drivers/lookout men about safety provisions during his day to day inspections and keep a record of the same. The Safety officer will prepare a monthly report of the safety inspections carried out and remedial action taken thereof and send it to the Project Manager of the contractor and the employer/engineer.
 7. The contractor should open new sites only after discussing the safety measures to be undertaken with his Safety officer and obtaining the permission from Employer/ Engineer.
 8. It shall be the duty of the Project Manager and Safety officer of the contractor that the instructions contained in the agreement related to safety and the same issued by the Railway/Employer/Engineer from time to time are strictly complied with.

Based on the above, it is advised that a thorough review of the safety provisions may be undertaken and it should be ensured that competent safety officers are available at all the work spots.

2. GENERAL INFORMATION AND SCOPE OF WORK

2.0 SCOPE OF WORK

The proposed work is in connection with the Doubling work between YPR-CSDR

Signaling Outdoor and indoor works with Distributed Electronic interlocking (EI) at Yesvantpur Jn in connection with doubling of Yesvantpur-Channasandra section of Bangalore Division

The EI systems will be of distributed type at Yesvantpur station. Further details are given in the invitation for the Tenders (IFT). The tenderers may submit the tenders for the works detailed in the IFT. It is proposed to take up this work, as it is important from the point of view of both passenger and freight traffic.

Introduction:

- i) This is part of the project for Doubling work between YPR-CSDR *section* of Bangalore Division.
- ii) The scope of work includes signaling indoor and outdoors work, fire detection, & alarm etc. The proposed work will be taken up in a phased manner and may involve 2 to 3 interim stage modifications.

2.1. **Details of Work:**

Approaches to the project site: The land acquired for the project caters for construction and operation of the proposed line. The contractor shall plan for approach roads to various sites of work conducting detailed survey and should include the cost of inputs for any such approach roads in his bid for the work. However, in case any existing road outside railway land has to be utilized for transportation of materials to the site of work and in the process the road gets damaged or needs to be strengthened and the authority owning the said road submits demand to GM(S&T) / K RIDE to carry out some specific works in order to strengthen/repair the road, GM(S&T) / K RIDE shall get such works executed through the existing contractor or any other agency and make payment for such work.

2.2	Salient features of the Station:-
A.	SIGNALING & TELECOMMUNICATION WORKS Signaling Outdoor and indoor works with Distributed Electronic interlocking (EI) at Yesvantpur Jn in connection with doubling of Yesvantpur-Channasandra section of Bangalore Division
i)	2.3 The Nature of work: The works to be executed can broadly be grouped as under: A. Other Activities: 1. Every precaution has to be taken such that there shall be least disturbance to road traffic during transportation of construction materials to the site of work.

	<p>2. Making and supply of 'As Built' drawings for the new assets created.</p> <p>2.3.2 SIGNALING & TELECOMMUNICATION WORKS</p> <ol style="list-style-type: none">1. Signalling indoor with electronic interlocking and outdoor works at Yesvantpur station2. Outdoor work of trenching and laying of cables, foundation for signals, location boxes, etc. wiring of location boxes, signal units, points machines, track circuits, axle counter jointing of signaling cables, earthing, RE protection, erection of electrical lifting barrier, painting and lettering of all outdoor gears, releasing of all outdoor gears.3. Designing and documentation including completion documents of signaling and telecom drawings for Yesvantpur station4. Supply installation testing and commissioning of fire detection and alarm system <p>Note : The above is not an exhaustive list covering all the works to be done under this Tender. Major works only have been listed for guidance.</p>
	<p>Special stipulations/features:</p> <p>Inspection of S & T Work</p> <p>2.4.6 The execution is required to be carried as per standard specifications of K-RIDE. However, specifications, drawings and other details mentioned in BOQ or in special conditions, wherever applicable will prevail over the standard specifications.</p> <p>2.4.7 The Signal & Telecom material to be supplied by the contractor as per RDSO Specifications/ Drawings will have to be procured from approved Vendors appearing in Vendor Directories of RDSO and to be supplied duly inspected by RDSO. In case where no manufacturers are available in approved vendors list issued by RDSO, procurement may be done through the firms included in RDSO Vendors for Developmental order as per Railway Board's letter No. 99/RS(G)709/1 dated 18.11.2016 and 2001/RS(G)/779/7 PT 1 dated 29.06.2017.</p> <p>In case of signalling relays, 20% of requirement of each type of relay can be procured from RDSO approved vendors for developmental order as per Railway Board's letter no. 2001/RS(G)/779/7 Pt 2 dated 25.06.2018.</p> <p>For procurement through RDSO Vendors for Developmental order, prior approval of K-RIDE's Engineer shall be obtained.</p> <p>2.4.8 The Signal & Telecom material to be supplied by the contractor as per TEC/DOT/BSNL specification will have to be procured from DOT/TEC approved firms. The inspection of such items will however be carried out by RDSO provided the value is more than value stipulated in inspection policy of RDSO.</p> <p>2.4.9 In case the contractor is supplying imported equipments from approved manufacturer, then in addition to manufacture's test certificate, such equipments shall be inspected by RDSO.</p>

	<p>2.4.10 Signal & Telecom items not inspected by RDSO/ RITES for any reason will be inspected by the Engineer / Authorized Representatives of K-RIDE. In case of any difficulty in inspection, K-RIDE may decide the authority of inspection, either by any other Govt. agency or by consignee. Whenever materials are inspected by Authorised Representatives of the K-RIDE/Engineer, the contractor will be required to furnish his or manufacturer’s Guarantee Certificate.</p> <p>2.4.11 The K-RIDE shall have full power to reject any material that it may consider defective or inferior in quality, workmanship, or otherwise not in accordance with the Specification and the K-RIDE’s decision shall be final, even though they might have been inspected by RDSO/RITES. The contractor shall remove forthwith any such material rejected and replace them promptly at his own cost. Inspected and accepted material, if damaged during transit shall be replaced by the contractor free of cost prior to installation.</p> <p>2.4.12 Inspection Charges of RDSO and RITES will be borne by the Contractor. <i>In case of Change of Inspection from RDSO/RITES to K-RIDE/Consignee, 1% of cost of material to be deducted by K-RIDE, as Inspection Charges.</i></p> <p>2.4.13 Items included in the list of items to be inspected by RDSO & RITES and are not inspected by RDSO/RITES for any reason whatsoever and will be inspected by the Authorized Representatives of K-RIDE. The following conditions will apply:</p> <ul style="list-style-type: none"> i) Material conforming to RDSO spec/drg is procured from RDSO approved source. ii) Contractor shall submit Manufacturer’s Guarantee Certificate for the material. iii) All such cases where change in agency of inspection other than mentioned in the schedule is required will be processed for specific approval of competent authority.
<p>2.4</p>	<p>Procurement and storage of materials</p> <p>2.4.14 Procurement of Track, S&T and Electrical Items has to be planned by the contractor in consultation with the Engineer and procurement plan shall be got approved from the Employer before placing any orders for such materials.</p> <p>Procurement Plan should be prepared in such a manner that those materials which have a shelf life like rubber pads etc may be procured in a staggered manner so that the materials are used before its properties get modified with age. The procurement of materials shall be planned as per the milestone/key activities specified in pursuance to GCC clause 8.3. If the material/product does not remain of required specifications at the time of its actual use, the same will be replaced by the contractor with materials conforming to Specifications at his own cost.</p>

The procurement of materials for the works by the contractor shall also be subject to the following:

(i) **Procurement Schedule:**

SN	Items	Schedule
1	Supply of items under S&T BOQ	<p>The procurement process should commence after GM/AGM/Sr.DGM in-charge of S&T portion of the work, approves the programme of procurement proposed by the contractor such that materials proposed for procurement are expected to be installed within a year of receipt.</p> <p>However, to facilitate formation work, Cables, Wires Location Boxes, Terminals, Level Crossings and other associated items required for replacement/shifting of existing cables/location box/level crossing etc to the extent of 20% of BOQ quantity or higher quantity may be procured at the beginning with the approval of GM of the department.</p>
2	The contractor would make out a list of items for which procurement process to start indicating the expected time of arrival at site and installation as per the period indicated above. The concerned GM/S&T would approve the programme.	

(ii) Based on the above schedule, the contractor shall prepare BOQ Schedule/Bill-wise procurement plan and submit a statement in the following format:

Procurement Plan- Installment No.1

BOQ Bill No:

Item No.	Description	BOQ Quantity	Quantity planned for procurement	Justification for placing order for procurement (lead, likely month of execution/installation)

Certified that all efforts have been taken to ensure that the quantity of materials being planned for procurement is as per the BOQ and as per the requirement at the site based on approved drawing.

Contractor

The requirement planned is commensurate with the progress of work and as per approved drawing/ design.

Engineer/PMC

Approved

GM/S&T

While submitting the 1st stage payment of the materials, a copy of the above approval certificate should accompany the bill/IPC.”

- (iii) **Reconciliation of materials after each milestone is reached:** For procurement of materials in subsequent instalment(s), the contractor shall enclose along with his proposal, a review statement of consumption already made or likely to be made in respect of materials already procured in the following format:

Review of the materials procured up to Previous Installment					
BOQ Bill No:					
Item No.	Description	Quantity procured upto previous Installment	Quantity Consumed/ installed	Balance Quantity	Remarks

Considering the consumption and further targets, second installment of materials may approved for procurement.

Contractor

The requirement planned is commensurate with the progress of work and as per approved drawing/ design.

Engineer/PMC

Approved
GM(S&T)

- 2.4.15 If the Contractor is required to purchase certain material(s) from firms in the approved list of RDSO/Zonal Railways /K-RIDE, as per terms and conditions of the contract, then the Contractor shall place orders accordingly on firms appearing in the approved list, as specified, on the date of placing the order and provide details of such orders placed to K-RIDE.

In case the contractor places an order on an approved firm, but the firm is subsequently de-listed before the supply is completed, then in such cases, if there are any outstanding orders on the de-listed firm, then wherever the balance delivery period is available, the extent of supply made by the

	<p>firm within the original delivery period, shall be accepted provided it passes the inspection of RITES/RDSO/inspecting authority specified in the contract. If the de-listed firm fails to deliver the material within the original delivery period, no extension shall be granted by the Contractor to such firms after date of issue of de-listing order. In case where delivery period has expired, no extension shall be granted and all such orders shall be cancelled and a fresh purchase action should be taken.</p> <p>The plant and materials etc. so procured for the works shall be properly stored on Site and protected against loss, damage or deterioration. For this purpose, the contractor shall make necessary arrangements of store godown/fenced area at site in Railway land as per directions of Engineer. In case the contract is terminated, the Employer shall have the right to take possession of the godown/store and reasonable cost of such store/godown shall be determined by the Engineer and included in the Final Payment Certificate</p>
	<p>CODES & SPECIFICATIONS 2.4.16</p>
2.5	<p>The works shall be carried out as per Standard Specifications of K-RIDE, which can be obtained on payment. Wherever reference is made in the Contract to specific standards and codes to be met by the goods and materials to be furnished and work performed or tested the provisions of the latest current edition or revision of the relevant standards and codes in effect shall apply, unless otherwise expressly stated in the Contract. Where such standards and codes are national or relate to a particular country or region, other authoritative standards which ensure an equal or higher quality than the standards and codes specified will be accepted subject to the Engineer's prior review and written approval. Differences between the standards specified and the proposed alternative standards must be fully described in writing by the Contractor and submitted to the Engineer at least 28 days prior to the date when the Contractor desires the Engineer's approval. In the event the Engineer determines that such proposed deviations do not ensure equal or higher quality, the Contractor shall comply with the standards specified in the documents.</p>
	<p>All goods and materials to be incorporated in the goods be new, unused, and of the most recent or current models, and that they incorporate all recent improvements in design and materials unless provided for otherwise in the contract.</p> <p>(a) The Standard Specifications of K-RIDE and the list of codes and manuals given in the annexure thereof shall be prime governing.</p> <p>(b) Where there is conflict between provisions in IRS & IS specifications, provisions in IRS specifications shall prevail.</p> <p>(c) Where there is no provision of specifications in IRS, provisions in IS specifications should be adopted. Where there are no provisions in IRS and IS Specifications, provisions in IRC Specifications should be followed.</p>

	<p>(d) For items not covered in IRS/IS/IRC specifications, BS-5400 Part 1 to 10 may also be considered.</p> <p>(e) The decision of Engineer shall be final and binding in the interpretation of the clause of the codes of practice and specifications of this tender and no claim whatsoever shall be entertained on this account from the Contractor.</p>
	SURVEY AND FIXING WORKING BENCH MARKS AND ALIGNMENT MARKERS: This Provision shall not apply
2.6	<u>Bench marks:</u> This Provision shall not apply
2.7	<u>Alignment:</u> This Provision shall not apply
2.8	<u>Responsibility for establishing and maintaining working bench marks and alignment markers :</u> This Provision shall not apply
2.9	<u>Issue of materials by Employer:</u> This Provision shall not apply
2.10	INTERFACING AND INTEGRATION OF WORKS :-
2.11	As a part of this work, indoor and outdoor works will be done in this bid. Hence interfacing for the purpose of integration of works between different Contractors of Civil and Electrical is of very much importance so that progress of work is not hampered. Coordination between all agencies has to be ensured. Such interfacing for the purpose of integration of works will arise between the partners of JV, in case the work is awarded to a JV or between the Contractor and his sub-contractors will arise or among different contractors. This has to be kept in view.
2.11.1	Land is available throughout the section for carrying out the works. However if additional land is required in yards/mid-section, necessary arrangements will be made for acquiring the land without affecting the progress of work.
2.11.2	The contractor shall take full responsibility in terms of organizing, managing, coordinating and administrating the interfacing of all components of works including all issues related to and arising out of such tasks and responsibility. The contractor shall interface with all concerned authorities and other contractors as required to complete the work satisfactorily within the stipulated period.
2.11.3	Under consideration and application of the above clause, the contractor shall and has also the obligation to liaise with the other contractors and Authorities to obtain all necessary technical information, all necessary information concerning organization of works, coordinating the works etc. which are necessary to assess, mitigate, take care of contractual obligations, risks, liabilities and whatsoever arising out of interfacing, engineering issues, organization of the works etc. The employer/engineer shall not be held liable in any way, throughout the preparation of the offer and/or execution of the works and/or maintenance period and/or defects liability period for any omissions, misunderstanding, negligence etc. arising out of interfacing, coordinating, organizing etc. of the works. The employer will not entertain any claim arising out of misunderstanding,

	<p>miscommunication, omission, withholding of necessary/required information or whatsoever between the concerned contractors/Authorities concerning interfacing, organizing etc. of works. In case of any claim arising from any of the contractors, as aforesaid, referring to interfacing and/or interfacing related issues, the Employer will hold the concerned contractors liable for not taking care of their contractual obligation concerning interfacing, organizing, co-ordination etc. of the related works.</p>
2.11.4	<p>It is the intention of the Employer that the overall interfacing, planning, scheduling, logistic administration inclusive of necessary logistic planning and all tasks that are necessary to guarantee proper co-ordination and proper interfacing of all activities during the complete execution of the works, is clearly understood and agreed to. Integrated programme shall set out in detail how the different contractors will work together in execution of the works. It shall also spell out the overall interfacing, planning, scheduling, logistic administration inclusive of necessary logistic planning and all tasks that are necessary to guarantee proper co-ordination and proper interfacing of the different activities by various agencies during the execution of the works. A master schedule incorporating the milestone of works completion by each contractor shall be included in the integrated programme to demonstrate the capability of all parties involved in the completion of the works wherever applicable. The essence of the integrated programme shall be that the contractors have both overall responsibility for the completeness and the timeliness of all the works and quality of the contractual works within the agreed time frame. Allowance need to be made by the contractors in their resources and pricing to ensure that proper co-ordination of the various items is incorporated in their contract.</p>
2.11.5	<p>Needless to say that commissioning of this doubling project requires close coordination among various agencies executing the works in this section, Engineer, Employer and the Railway authorities. The contractor shall therefore plan all his works requiring interfacing, like works in mid section, station yards, with other agencies, meticulously, in consultation and coordination with all concerned parties, in advance, for expeditious execution, without causing any delay either to his works or those of others.</p>
2.11.6	<p>The contractor shall strictly adhere to the work plan made for works requiring interfacing. Any delay either on his part or on the part of other agencies and other bottlenecks that could affect the pace of works shall be informed to the Engineer in time so as to enable him to take corrective steps.</p>
2.11.7	<p>If, in the opinion of Engineer, any delay in execution of any part of the Project requiring interfacing is attributable to the failures of the contractor to take adequate steps for smooth execution of such works, then the Engineer shall have the right to take necessary steps to organize and streamline such works, including excluding the requisite portion of work from the scope of the Contractor and getting the same executed by other agencies, at the risk and cost of the contractor.</p>
2.11.8	<p>Damages to property: The contractor shall organize all his activities so as not to cause any damage to the property of Railway or that of other agencies or any third party. In spite of taking all precautions, in the unfortunate event of any damage to the property, then the contractor shall not only indemnify the Employer of the claims made by the affected parties</p>

	but also settle the matters with the affected parties as per law. If the nature of damage is one of that affecting the train movements or causing a safety hazard to the public, then the situation will be treated as an emergency and the Engineer reserves the right to take all necessary steps as deemed necessary to restore train operations or to remove the hazardous situation or to mitigate the damage, at the risk and cost of the contractor.
2.11.9	SURVEY EQUIPMENT
2.12	The contractor should provide the survey equipment and other accessories as per the instructions of Engineer as and when required. He should also provide all necessary help as required by the Engineer for checking the works, whenever required.
	Power Line Crossings: DELETED
2.13	All power requirements for execution of works shall be arranged by the Contractor from his own resources. Subject to availability of power, the Employer/Engineer will recommend to the Railway Authorities for providing power connection. The Contractor shall bear the cost of installation and payment of necessary charges for providing such power connections as per the Terms and Conditions of the Railway.
2.14	

2.15 Provisional Acceptance:

- i) Immediately after completion of works/such part of works, the Contractor shall certify and advise the Engineer in writing that the works are (i) complete (ii) ready for satisfactory commercial service and (iii) ready to be handed over. He will also place at the disposal of the Engineer the required staff for checking it and putting it into operation.
- ii) The test or tests as stipulated in approved Technical Specifications shall be carried out jointly by the Railway / Engineer and the contractor within a month after the receipt of the Contractor's notification as stated in sub-Para above.
- iii) The provisions contained in the GCC shall be followed for taking over of the installations.

3. SITE FACILITIES FOR THE EMPLOYER AND THE ENGINEER

The Contractor shall provide for the use of the Employer / Engineer, equipment, communication & drawing facilities throughout the course of the work and for such period of time during the defects liability period as the employer & Engineer may require, The details of facilities are detailed below: All the facilities under this clause will continue to be maintained by the Contractor free of cost till the defect liability period is over. Thereafter the Contractor shall take away all the materials & equipment etc which will be the property of the Contractor.

3.2 SITE OFFICES: DELETED

3.3 FURNITURE AND OTHER OFFICE EQUIPMENT: DELETED

3.4 TRANSPORT:

PROVISION OF MULTI UTILITY ROAD VEHICLE:

The contractor at his own cost shall provide one Multi Utility Road Vehicle in good condition with Driver, fuel etc., for the use of K-RIDE officials during the currency of the work including extended completion period.

3.5 OFFICE MAINTENANCE: DELETED

3.6 EQUIPMENT FOR USE OF THE ENGINEER:

The Contractor shall provide new equipment and software as listed below and maintain them for the exclusive use of the Employer and the Engineer. The Contractor shall provide and maintain the following equipment for the use of the Engineer and the Employer within one month from the date of commencement of the works until the work is completed. On completion of work, the equipment shall be property of the Contractor.

(a)	Desktop Computer One nos.	With minimum specification of Intel Core i7, 3.4 GHz, 3 MB Cache, 4 GB DDR3 RAM, 500 GB Hard Disk Drive, DVD Writer, 18.5" colour TFT monitor, 10/100 LAN Card, Modem Card, Operating System - Windows 8 Professional or higher preloaded with media and documentation and certificate of authenticity and Microsoft Security Essentials preloaded antivirus software.
(b)	Laptop rugged – One Nos.	With minimum specification of Intel Core i5, 4 GB RAM, 500 GB Hard Disk Drive, 11.6" color display, 2xUSB-2.0, standard keyboard Weight - not more than 2.5 kg, Battery backup - minimum 4 hrs Operating System - Windows 10 or higher preloaded with media and documentation and certificate of authenticity and Microsoft Security Essentials preloaded antivirus software. A laptop bag and Adapter/Battery charger shall also be provided with the laptop.
(c)	Printers – 2 nos. (A4 size – 1 No. and A3 size – 1 No.)	The A4 size printer shall be all in one office jet having features of Fax, Scanner and Printer, A3 size printer shall be Colour Office jet with a print speed of up to 8 pages at 800 dpi or More.
(d)	Application software	(i) Microsoft office latest release. (ii) AUTOCAD 3D 2015 (iii) M S Project/ Sure Track. (iv) PDF Converter/Professional
(e)	UPS system with sufficient power backup (with minimum backup time of 30 minute) to meet the sufficient power load in case of power disruption.	
(f)	Surge Protection Devices (one for each computer and printer as given above)	
(g)	Power supply for the systems is to be AC 240 volts, 50 Hz from normal building wiring circuit mains, power regulator, stabilizer or transformer should be supplied by the Contractor for the computer systems such that the systems can function efficiently.	
(h)	2 MBPS internet connection with Wi-Fi facility so that multiple devices can be connected.	

Note: In case of failure to provide the equipment including original software & internet connectivity within one month, penalty @ Rs 25000/- Per week or part thereof will be imposed.

3.7 Documentation

A complete set of documentation will be supplied with each System. The documentation should be self-tutorial in nature and be readily understood by non-computer personnel. The following manuals will be supplied with the system:

- (a) Manual on how to operate the equipment; and
- (b) Manual on how to use the facilities and software provided by the supplier (including languages and utilities).

4.0 SPECIFICATIONS

Standard Specifications for Materials and Works of K-RIDE

Separate priced booklet containing Indian Railway/South Western Railway Standard Specifications for Materials and Works Civil, Electrical and Signaling and Telecommunication) are available in K RIDE office. These specifications shall be applicable for all works covered in this contract

It is presumed that bidders have gone through K-RIDE's Standard Specifications for Materials and works (Civil, Electrical and Signaling and Telecommunication) including latest correction slips issued up to the date 28 days prior to the deadline for submission of bids before quoting the rates.

Works are to be executed as per above referred specifications except for Methodology of Mechanised Laying and Packing of Track, which is specified below-

METHODOLOGY OF MECHANISED LAYING AND PACKING OF TRACK: DELETED

- 4.1 TECHNICAL SPECIFICATION FOR CONSTRUCTION OF SERVICE & RESIDENTIAL BUILDINGS :** This provision shall not apply.

5. PERSONNEL

The Bidder shall deploy, as per the programme, the minimum number of personnel for the key positions with requisite qualification and experience as mentioned here under:-

S. No	Position	Minimum No. of Personnel	Qualification	Minimum Experience In Similar Work [years]
1	Sr. Engineers	2	Engineering Graduate in Electronics/Elect.	3 years' Experience in construction of EI/RR/PI
2	Supervisors/S &T	2	Diploma in Electronics/Elect.	Minimum 3 years' experience in construction of EI/RR/PI
3	Draftsman with knowledge of AUTOCAD S&T	1	Minimum Diploma in Electrical/Electronics/Communication Engineering OR a combination of basic streams of Electrical/Electronics/Communication Engg.	3 years with AutoCAD (S&T) experience.
4	Wire man	6 WireMen + 8 Asst. WireMen per station during Pre NI & NI	Wireman	Minimum Experience of 5 years

Note:

- (1) The programme for deployment of personnel shall be conveyed by PMC/Employer and personnel shall be deployed within 30 days of the stated requirement. In case of failure to deploy any personnel within 30 days of the stated requirement, a penalty shall be imposed for each day of delay as under
 - a) Rs.1000 per person per day for Sr. Engineers, Supervisors / S&T and Draftsman with knowledge of AUTOCAD S&T;
 - b) Rs 500 per person per day for Wire man and other personnel
- (2) On completion/likely completion of activities concerned to a particular

personnel, demobilization of that personnel shall be requested by the Contractor at least 30 days in advance and demobilization shall be done with the approval of PMC/Employer only. In case demobilization is done without approval of PMC/Employer, the penalty mentioned in note (1) above, as relevant, shall be imposed for each day of absence of the personnel.

- (3) The professional qualification requirement can be relaxed by the concerned GM (S&T)/K RIDE on recommendation of the concerned AGM/JGM(S&T) in case of ex-Railwayman who has worked in Signalling and Telecommunication Engineering department of Railway in a position of Gazetted officer for Sr Engineer (S&T) / Junior Engineer or above for Supervisor (S&T) and has relevant experience not less than that prescribed for minimum professional qualification.
- (4) The experience requirement can be relaxed by the concerned GM (S&T)/K RIDE if he is satisfied with reasons put forth by the contractor for failure to deploy personnel with requisite qualification and experience and he also finds the proposed personnel otherwise suitable for the job.

6. EQUIPMENT

The Bidder shall deploy, the minimum number of equipment for execution of the work as per the mutually agreed programme as mentioned hereunder:

S. No.	Equipment Type and Characteristics	Min. Number Required
Equipment types and characteristics for S&T work		
1	Portable Generators of all capacities as per site requirement	2 Nos.
2	Drilling machines of all type as per site requirement	2 Nos
3	Track Drilling machines of all type (mechanical cycle chain type and electrical type) as per site requirement	2 Nos
4	Grinders of all types as per site requirement	2 Nos.
5	Jacks for cable Laying	2 Sets
6	Concrete Shutters for Apparatus case full	4 Sets
7	Concrete Shutters for Apparatus case half	2 Sets
8	Concrete Shutters for Signal Post	2 Sets
9	Concrete Shutters for Shunt Signal	1 Sets
10	Tool Kits for fitters – Mechanical Installation gang (Location Box / Apparatus cases, Signals, etc.)	02 Sets
11	Tool kit for fitters – Electro-mechanical gang (Track circuiting, Point machines, Axle counters, Circuits controllers, Level locks & relay Rack equipment.)	02 Sets
12	Tool kit for locking fitters cum LC gate interlocking. Key lock point interlocking & ground level frame	1 Sets

	interlocking.	
13	Wireman's tool kit consisting of Multimeter, Meggar, Box spanner, Nose Plier, Holding Plier, buzzer, wooden hammer, Clamp type ampere meter etc.	04 Sets
14	Carpenter tool kit	1 Sets
15	Earth tester	1 Set
16	Torches	8 Nos.
17	Material loaders / Mini trucks /Matadors / Bolero's	1 Nos.
18	VHF – Walkie Talkies Sets	2 Sets

Note:

1. Any Equipment not required further can be demobilized with the prior approval of the Engineer.

The records of mutually agreed programme of deployment as well as request for demobilisation of any equipment/plant and approval of the same should be maintained in a register.

2. Failure to deploy the above equipment as per mutually agreed programme shall attract penalty @ Rs.20,000/- per day of delay.

3. The type of equipment specified can be changed by the Engineer depending upon suitability of the equipment as per site conditions with the approval of GM(S&T)/K RIDE concerned subject to the following;

- (i) The total rate of production/output of proposed number and type of equipment should be equal to or more than that of the number and type of equipment stipulated in the contract agreement and quality of work is not compromised in any way;
- (ii) Eligibility and Qualification Criteria (EQC) in the bid document did not include any past experience criteria of execution of a key activity with the use of particular type of equipment proposed to be changed;
- (iii) Higher rates for works were not justified in the estimate or BOQ on account of use of particular type of equipment proposed to be changed;
- (iv) Financial implications due to change in type and number of equipment shall be prepared and signed by both the parties and placed on record. If any financial benefit is found to accrue to the contractor, the same shall be recoverable from the contractor's bills.
- (v) If the equipment proposed to be changed is covered under penalty clause specified in note above then the applicable rate of penalty per equipment shall be modified in proportion to increase/decrease in number of equipment.

S.No.	Description	Page No.
26	TECHNICAL SPECIFICATION	264-344

K-RIDE

PART -(I)
TECHNICAL SPECIFICATIONS (GENERAL)

1. GENERAL:

The S&T works include supply and execution of items as well as work in the relay/equipment room and in the field. It will be the responsibility of the Tenderer to commission the complete interlocking with outside gears i.e., points, signals and other field signalling equipment, installation, testing and commissioning of system including transportation of all the equipment to site of installation. Testing and commissioning will be done in association with K-RIDE Engineer and staff. The work shall be carried out according to the drawings approved by the K-RIDE and shall conform to the provision of Signal Engineering Manual and schedule of dimensions. The contractor shall be solely responsible for the proper execution of the work as per specification. Description of Outdoor work is given in the respective item of Schedule of work, however, Broad guidelines for various activities in connection with outdoor works are as follows. In case of any conflict with the description in Schedule of Work and these guidelines, the details in the Schedule of work shall prevail.

2. CABLE LAYING

Guidelines on the Cable Laying (Document No. RDSO/SI/G/2010, Version 1.1 or latest) issued by RDSO dated 04.02.2014, which shall be followed while laying the signaling, power, Telecomm and OFC in the station section and block section.

- 1) All main cable shall be laid in RCC duct/ Split RCC pipes/Polyolefin ducts.
- 2) Tail cable shall be laid through DWC/HDPE/RCC split pipes of suitable sizes with non-flame and anti-rodent properties, proper coupling and cable be laid at depth not less than 1000mm from ground level.
- 3) For laying of signaling cables in the station yards from Home to Home signal Manual trenching is recommended.
- 4) From Home to distant signal and beyond into block/automatic section - mechanized trenching is recommended.
- 5) Under road/platforms/railway tracks/difficult terrain etc., trench less horizontal directional drilling (HDD) method may be adopted under the supervision of competent staff for laying of GI/DWC-HDPE pipe.
- 6) Trenches shall be straight as far as possible and steep angles shall be avoided, clearing roots of trees, rocks etc in all types of soils.
- 7) The bottom of the trench shall be levelled and got rid of any sharp materials like stone chips, iron pieces etc.
- 8) It is desirable that the trenches do not remain uncovered for long period; instead cables are laid and refilling done on the same day.
- 9) Before commencement of the laying, inspection of the trench and inspection of protection works shall be carried out.
- 10) Backfilling of the trenches shall be done properly. The earth excavated shall be put back on the trench, rammed and consolidated.
- 11) During excavation, the earth of the trenches shall not be thrown on the ballast. The earth shall be thrown by the side of the trenches away from the track.

3. Cable laying in underground

- In AC electrified areas cables shall be laid underground only.
- Cables may be laid underground, either in the trench, in ducts, in cement troughs, in pipes or in any other approved manner.
- Cable is generally laid parallel to the track beyond Home signal with minimum deviations and on one side of the yard.
- As far as possible, cable shall be crossed only at two locations, i.e. one crossing on each side of the yard.
- The cable laid parallel to the track shall be buried at a depth of minimum 1.0 metre (top most cable) from ground level. Those laid across the track must be minimum 1.0 metre below the rail flanges.
- However, in case of rocky soil, the depth may be reduced suitably.
- For laying of tail cables the depth shall not be less than 0.50 metres.
- In theft prone areas the cables may be laid at a depth of 1.2 metres with anchoring at every 10 metres.
- The minimum width of manually made cable trenches shall be kept as 0.3 meters.
- The cable shall be covered with a layer of sand or sifted earth of 0.10 metre thickness and thereafter a protective cover of trough or a layer of bricks shall be placed.
- Normally, not more than 12 cable are to be laid in one trench.
- It is recommended that cables are laid in RCC duct up to home signal on both side of the station and may be extended up to distant, if required. This will also help later for laying of additional cable later without carrying out trenching.
- For the safety of the track: (i) Outside the station limits, the cables shall generally be laid at not less than 5.5 metre from the centre of the nearest track. (ii) Within the station limits, the trenches shall preferably be dug at a distance of not less than 3 metre from the centre of the track, width of the trench being outside the 3 metre distance. (iii) At each end of the main cable an extra loop length of 6 to 8 metre shall be kept burried at same depth as that of cable in the same trench to ensure that cable is free from theft/outside interference.
- Before starting cabling work location boxes shall first be erected so that cable after laying is directly taken inside location box.

4. Cable laying in ducts

RCC, masonry, polyolefin ducts or any other approved type of ducts may be used for laying the cable. The ducts shall have suitable covers and shall rest on walls of duct.

5. Track Crossing

1. As far as possible, cable shall be crossed only at two locations, i.e. one crossing on each side of the yard.
2. When a cable has to cross the track, is shall be ensured that
 - i) The cable crosses the track at right angles
 - ii) The cable does not cross the track under points and crossings
 - iii) The cable is laid in concrete/GI/CI/PVC/DWC-HDPE pipes or suitable ducts or in any other approved manner while crossing the track.
 - iv) Cable laid across the track must be 1.0 meter (minimum) below the rail flanges.
 - v) No digging shall be done below the sleepers. Digging work while crossing a track shall be done between sleepers in the presence of a Railways representative.

6. Road Crossing

1. The cable is laid in concrete/GI/CI/PVC/DWC-HDPE pipes, suitable ducts or in any other approved manner while crossing the road at the depth of 1 metre from the ground level. It shall extend 1 metre (minimum) on each side of the road keeping in view the future increase of width of the road.
2. Suitable precautions may be observed while laying of pipes and refilling the trench depending upon the type of road (e.g. heavy or light traffic, broad or thin) so as not to block the road traffic for a longer period.
3. Whenever a cable is laid across an important road, particularly one with a special surface, a spare pipe may be laid, through which a cable can be drawn when required. It will be advantageous to leave a lead wire of G.I. wire in the pipe for drawing the cable in future.

7. Cable laying on bridges/culverts

1. Wherever practical, the cable may be taken underground across the drain bed at a suitable depth for crossing small culverts with low flood level.
2. Where cable may not be taken underground across the drain bed, cable shall be taken on the culvert through GI/DWC-HDPE pipe of suitable sizes.
3. When cables have to cross a metallic bridge, they shall be placed inside a metallic trough which may be filled, as an anti-theft measure, with sealing compound. The cable shall be supported across the bridge in a manner which would involve minimum vibrations to the cable and which will facilitate maintenance work.
4. In case of arch bridges, cable shall be taken through GI/DWC-HDPE pipes on top of the arch adjoining the parapet wall. The pipe shall be covered with ballast.

8. Laying near to sleeper

In places where cables are to be laid within 1 metre from sleeper end, digging beyond 0.50 metre shall be done in the presence of an official from Engineering Department, and the laying of the cable and refilling of trench shall be done with least delay. Laying may be undertaken under block protection as needed.

9. Jumper cable for track circuits

1. Jumper cable should be tied with the nearest sleeper, on wooden sleepers using iron clamps/hook and on PSC sleepers using clamps. Laying of Signaling cables
2. Cable shall be buried underground in the line of sleeper and taken to TLJB, where sleeper ends.
3. Wherever required, cable may be laid in DWC-HDPE pipe.
4. Jumper cable shall be laid at least 0.5 metre below ground level excluding ballast depth.
5. Jumper cable shall be laid neatly in squared manner and shall not be kept in loose coils above the ground near TLJB.
6. Top surface of TLJB shall not be 1 feet above rail level.

10.Cable Marker

Cable markers wherever provided shall be placed at 25 metre interval in station section and 50m interval in block section and at diversion points.

11.Storing and transportation of cable

1. Cable drums shall not be stacked on flat side. Suitable stoppers or wooden wedges shall be placed for stability.
2. Cable drums shall have easy access for lifting and moving.
3. While unloading from a vehicle the drum shall not be dropped on the ground directly to avoid damage due to impact. Fork lifter or ramp shall be used.
4. When rolling the cable drum either for unloading or transportation, the drum shall always be rotated in the direction of the 'arrow' which is marked on the drum. Wooden drums frequently have an arrow marked on their flanges to indicate both the directions that cable to be wound on to them and also the direction in which the drum is to be rolled.
5. During storage, the ends of the cable should be effectively sealed by end cap or in any other approved manner to avoid water entry into the cable.
6. Storage in covered shed is desirable to protect against direct exposure to sun.

12.Paying out the Cable

1. For paying out cables, the cable drums shall be mounted on cable wheels or on axle whichever is available. It shall be ensured that no kink is formed while paying out the cable.
2. The cable drum shall be brought as close to the cable trench if possible, with a clearance to the ground by 5 to 10 cm. and the cable shall be laid along the trench.
3. A party of labourers shall move along the trench carrying cable at suitable intervals so that cable is not damaged due to dragging along the ground or bent unduly.
4. In no case, shall the drum be rolled off on to the road for laying the cable and the cable dragged on the ground for laying purposes.
5. Where the cable drum is in damaged condition the cable may be placed on a horizontal revolving platform and the cable paid out in the same manner as given above.
6. Paying out of cable shall be done by rotating the cable drum and not by pulling the cable with excessive force.

13.Testing of Cable

Before the cable is laid in the trench, a visual inspection of cable shall be made to see that there is no damage to the cable. It shall be tested for insulation and continuity of the cores. Thereafter, the cable shall be laid into the trench. Record of insulation and loop resistant must be maintained.

14.Special requirements in 25kV AC electrified area

1. Only unscreened cable shall be used.
2. Screened signalling cable may be used on signalling installations where screened cable is already in use and site condition demand its further use.
3. PVC insulated PVC sheathed and armoured unscreened cable to an approved specification (IRS-63) shall be used for carrying signalling circuits. Only approved type (IS-1554) power cable shall be used for signalling purposes.
4. The screened cable, if used, shall be PVC insulated, armored and to an approved specification IRS S-35.
5. The cable shall be so laid that it is not less than one meter from the nearest edge of the mast supporting the catenary or any other live conductor, provided the depth of the cable does not exceed 0.5 meters. When the cable is laid at a depth greater than 0.5 meters, a minimum distance of 3 meters between the cable and the nearest edge of the O.H.E structure shall be maintained. If it is difficult to maintain these distances, the cable shall be laid in concrete/heavy duty HDPE/Ducts or any other approved means for a distance of 3 meters on either side of the Mast. When so laid, the distance between the cable and the mast may be reduced to 0.5 meters. These precautions are necessary to avoid damage to the cable in the event of the failure of an overhead insulator.
6. In the vicinity of traction sub stations and feeding posts, the cable shall be at least one metre away from any metallic part of the O.H.E and other equipment at the substation, which is fixed on the ground, and at least one metre away from the substation earthing. In addition, the cable shall be laid in concrete or heavy-duty HDPE pipes/or other approved means for a length of 300 meters on either side of the feeding point. As far as possible, the cable shall be laid on the side of the track opposite to the feeding post.
7. In the vicinity of the switching stations, the cable shall be laid at least one metre away from any metallic body of the station, which is fixed in the ground, and at least 5 meters away from the station earthing. The distance of 5 meters can be reduced to one metre provided the cables are laid in concrete pipes/ heavy-duty HDPE pipes/ducts or any other approved means.
8. Where an independent Earth is provided for an OHE structure, i.e. where the mast is connected to a separate Earth instead of being connected to the rail, the cables shall be laid at least one metre away from the Earth.
9. Where there are O.H.E structures along the cable route, the cable trenches shall as far as possible, be dug not less than 5.5 meters away from the centre of the Track.

Telephone : 2451200 Extn. 42666
: 2465761
Tele Fax : 91-0522-2452332
E-mail : dsig8rdso@gmail.com
Mob. : 9794863313



Director/Signal
Room No. 205, 2nd Floor, Annexe-I Building,
Government of India - Ministry of Railways
Research Designs & Standards Organisation
LUCKNOW - 226011

Letter No: STS/Cable-Laying Practices Vol.- IV

Date: 09/05/18 ✓

मुख्य संकेत एवं दूरसंचार अभियन्ता,	Chief Signal & Telecom Engineer,
मध्य रेलवे, मुंबई सी.एस.टी.- 400001	Central Rly, Mumbai CST- 400 001
पश्चिम रेलवे, चर्च गेट, मुंबई - 400020	Western Rly, Churchgate, Mumbai - 400 020
पूर्व रेलवे, फेयरली प्लेस, कोलकाता - 001	Eastern Rly, Fairlie Place, Kolkata - 700 001
दक्षिण पूर्व रेलवे, गार्डन रीच, कोलकाता - 43	South Eastern Rly., Garden Reach, Kolkata - 43
उत्तर रेलवे, बड़ौदा हाउस, नई दिल्ली - 01	Northern Rly., Baroda House, New Delhi- 01
पूर्वोत्तर रेलवे, गोरखपुर - 273012	Northeastern Rly., Gorakhpur - 273 012
पूर्वोत्तर सीमान्त रेलवे, मालीगांव, गुवाहाटी 11	North Frontier Rly., Maligaon, Guwahati- 011
दक्षिण रेलवे, पार्क टाउन, चेन्नई - 600 003	Southern Rly., Park Town, Chennai -600 003
दक्षिण मध्य रेलवे, सिकन्द्राबाद -500 371	South Central Rly, Rail Nilayam, Secunderabad-71
पूर्व मध्य रेलवे, हाजीपुर दू 841 101	East Central Railway, Hazipur - 841 101
उत्तर पश्चिम रेलवे, जयपुर-300206	North Western Railway, Jaipur-300206
पूर्व तटीय रेलवे, ग्राउन्ड तल, उत्तरी ब्लाक, समन्त विहार, भुवनेश्वर-17	East Coast Railway, Rail Vihar, Ground floor, North Block, Samant Vihar, Bhubneshwar -17
उत्तर मध्य रेलवे, गंगा काम्पलेक्स, सूबेदारगंज, इलाहाबाद।	North Central Railway, Ganga Complex, Subedarganj, Allahabad.
दक्षिण पश्चिम रेलवे, क्लब रोड, केशवपुर, हुबली- 580023	South Western Railway, Club Road, Keshavpur, Hubli - 23
पश्चिम मध्य रेलवे, जबलपुर दू 482 001	West Central Railway, II floor, DRM Office, Jabalpur - 01
दक्षिण पूर्व मध्य रेलवे, आर0ई0 ऑफिस काम्पलेक्स, बिलासपुर- 495004	South East Central Railway, R. E. Office Complex, Bilaspur-495004
मैट्रो रेलवे, 33/1, जवाहर लाल नेहरू रोड, कोलकाता-71	Metro Railway, 33/1, Jawaharlal Nehru Road, Kolkata -71
कोर , नवाब युसुफ रोड सिविल लाइन्स इलाहाबाद -01	CORE, Nawab Yusuf Road, Civil Lines, Allahabad- 01

Sub: Plastic Cable Ducts / Tray. ✓

Ref: This office letter No. STS/Cable-Laying Practices Vol.- IV Dated 09.11.17 in reference to Railway Board's Letter no. 2006, 2012, 2014 and 2014/Sig/SGF/3(CABLE) dated 09/08/12, 13/05/14, 10/07/14 and 29/08/16.

In continuation of above as referred, Railway board was enclosed technical and other details of plastic ducts/tray. These cable ducts being developed for laying of all types of cables e.g. Signalling, Telecommunication and Power etc.

Railway Board had further informed vide above referred letter that these cable ducts may be very useful for application in suburban sections where cable trenching and digging is a severe problem due to space constraints, proximity of other cables and utilities, traction bonds and cables etc.

To comply above mentioned Railway Board letters, all the railways are once again advised to send their performance feedback/Remarks, specification being followed with testing details, installation practices etc. to RDSO.

RDSO has already issued guidelines vide RDSO/SI/G/2010 version 1.1 dated 04/02/2014 as a policy for laying of signalling cable. To ensure quality of plastic cables duct/tray, technical specification and testing procedures as attached with above referred Railway board letter is summarized and enclosed herewith for comments on the performance. ✓

DA : As above enclosed by Railway Board
as Annexure- I

9.5.18
(A.K.Singh)
Director/Signal-VIII
for Director General /Signal

RDSO - Ref No: STS/Cable-Laying Practices Vol- IV/ Dated: 09/05/2018

Annexure- I

I. Technical Specification of – Injection Moulded – Plastic Cable Duct / Trays

1. Basic/ Minimum Technical specifications /Testing procedures & Check list

Properties	Type – I (2434)	Type- II (1020)
Width (Internal / External)	240mm/340mm	100mm/200mm
Height (Internal / External)	155mm/ 230mm	155mm/230mm
Weights per Mt/ PC (Including Bottom and top cover)	8.00 kg (Minimum)	5.00 kg(Minimum)
Length per pc / per mtr -	1000mm (appx)	
Material	Polyolefin / polymers/Engineering plastics	
Fire Behavior	Fire Protection Class K 1 in accordance and referenced with DIN 53438 part-2	
Breaking Load (Minimum)	≥ 12 KN,at room Temperature, over the specified surface area of: 250mm x 150mm for Type I (2434) 250mm x 75mm for Type II (1020)	
Thermal Characteristics (Type Test– Frequency 6 months)	Thermal stability from -10 degree to + 70 degree As per IS 9000- part- 2 & part- 3 :1977	
Electrical Characteristics (Type Test– Frequency 6 months)	Dielectric Strength: 48 kV (Min breakdown voltage) as per IEC-60243-1-2013	
Tolerance in Dimensions	(+/-) 10mm	

2. The cable ducts should be horizontally attachable to each other with male/female swallow tail connections with suitable detachable/ push fit cover.
3. Required accessories/ earth pins etc. for fixing of cable ducts should be supplied, if required at the time of installation.
4. The cable duct should have predetermined breaking points/ perforated opening/ outlet on the sides for taking cables inside/outside the duct.

II. Tests Procedures:

1. Load Bearing Capacity (at Room temperature of 27^oC):
 - 1.1 Sample - Complete cable channel with cover.
 - 1.2 Conditioning for room temperature test - 27^oC ± 2^oC for 2 hours.
 - 1.3 Sampling size of each test = Complete cable channel with cover.

RDSO - Ref No: STS/Cable-Laying Practices Vol- IV/ Dated: 09/05/2018

1.4 Test Procedure:-

- 1.4.1 The test specimen to be tested should be in locked position and to be kept on the surface in such a way that bottom surface of the box will get total support. The force shall be applied in the Centre of the cover. A rubber or wooden pad should be introduced in between the plate and box to avoid direct rupture due to sharp edges of the plate. The load test equipment should have at least load capacity of 12 KN.
- 1.4.2 The force measurement should be carried out with a load cell with an accuracy of 1N. Using hydraulic test cylinder, the force should be continually increased.
- 1.4.3 This load to be increased up to the 12 KN. Then the test may be discontinued once the sample survives the minimum breaking load criteria.
- 1.4.4 Size of steel plate shall be as under:
Type 1 (2434)- 250mm x 150 mm
Type 2 (1020)- 250mm x 75 mm
- 1.5 Acceptance criteria: Breaking load \geq 12KN

2. Determination of Burning Behaviour (Edge combustion):

- 2.1 Sample - 190mm X 90mm (to be cut from the cable tray).
- 2.2 Sampling – One sample should be tested.
- 2.3 The Test Apparatus for this test shall comply the standard DIN: 53438 Part-2.

2.4 Test Procedure:-

- 2.4.1 A specimen of 190mm X 90mm should be mounted in a vertical position.
- 2.4.2 A measuring mark is to be made at a distance of 150mm from the bottom edge.
- 2.4.3 The height of flame is to be adjusted to 20mm.
- 2.4.4 The angle of burner should be inclined to 45° to the surface of the test specimen.
- 2.4.5 The flame is to be applied to the edge of sample for 15 second.

2.5 Acceptance Criteria:-

- 2.5.1 The test shall satisfy the requirements of classification K1. (Classification K1: If the tip of the flame of the burning specimen does not reach the measuring mark or if the flame has extinguished.)

RDSO - Ref No: STS/Cable-Laying Practices Vol- IV/ Dated: 09/05/2018**III. Check lists for Testing of The cable Ducts:**

1. Size of Sample: For Acceptance Test- As per standard sampling from lot and for Type Test - One sample.
2. Following Acceptance Tests & Type Test shall be conducted.

SN	Tests Parameters	Requirements	Observations	Remarks
Acceptance Tests				
2.1	Visual	No sharp edges, burrs, or surface projection which is likely to damage conductor or cable.	No sharp edges, burrs or surface projection should be found.	
2.2	Dimensions / Min. weights per mtr/pc (cover and bottom) Length- 1000mm both the types Tolerances +/- 10mm	For Type – I (2434) Width = 240mm (int.) / 340mm (ext.) Height = 155mm (int.)/ 230mm (ext.) Weight : 8.00Kg (min) per meter For type – II (1020) Width = Int. -100mm / Ext -200mm Height = Int.-155mm / Ext.-230mm Weight : Per Mtr 5.00 Kg (min)	Dimensions should be within limit.	
2.3	Load bearing capacity at room temperature	Conditioning for room temperature test = 27 ⁰ C ± 2 ⁰ C for 2 hours Min. breaking load ≥ 12 KN	No crack or failure of the cable channel should observed	
2.4	Burning Behavior	The test shall satisfy the requirements of class - K1/ with DIN 53438 part-2.	It should confirm to Fire Protection Class K -1	
2.5	Outlet for taking cables inside/outside of duct.	Cable Ducts/ Tray should have predetermined breaking points/ perforated opening / outlet on the sides for taking cables inside/outside.	Plastic cable duct should confirm the requirement.	
Type Tests				
2.6	Thermal Characteristics	Thermal stability from -10 degree Celsius to + 70 degree Celsius as per IS 9000- part- 2 & part- 3 :1977	Test reports shall be submitted from approved laboratory.	
2.7	Electrical Characteristics	Dielectric Strength: 48 kV (Min breakdown voltage) as per IEC-60243- 1-2013.	Test reports shall be submitted from approved laboratory.	

15.FOUNDATION & ERECTION OF APPARATUS CASES:

15.1 The work consists of pit excavation, casting foundation with bolts of adequate size having cement concrete of ratio 1:3:6 as per:-

- (i). Drg. No. SG/CN/02/6 (Apparatus case full size)
- (ii). Drg. No. SG/CN/02/7 (Apparatus case Half/ Quarter sizes)

The location of apparatus case will be indicated by KRIDE/Railways.

15.2 Two 'E' types locks on the doors of full size apparatus case and one 'E' type lock on the front door for half size apparatus cases shall be firmly fixed and tested with 'E' type key . Locking and unlocking shall be smooth with least force. Suitable fixing arrangements for 'E' type lock on the door of apparatus case shall be fabricated by the contractor, if such arrangements does not exist. One hard wood shelf plank 37mm thick, planed and varnished shall be firmly fixed for all types apparatus cases/ battery boxes. Also latching arrangement for the back door shall be provided, if required.

15.3 All the apparatus cases (Full/Half/Quarter) are to be painted with Aluminum paint on the outsides surface and the location numbers are to be painted in 'Bold' letters. Inside of location box shall be painted with white/Aluminum enamel paint.

15.4 CABLE TERMINATION BOX FOR CABLE THROUGHING, POINT MACHINE:

15.4.1 Excavating earth and casting concreted foundation as per Drg. No. SG/CN/02/8 and C.T. boxes are to be erected on Rails/L-angles vertically by using suitable size of bolts and nuts. The cables shall be taken through 2 Nos. of G.I. Pipes of size 32mm inner dia and 300mm length fixed at the bottom of the CTB with suitable fixing arrangements. It shall be ensured that there should be no break in the cable core during the process of taking the cables through pipes.

15.4.2 In case of CTB for Point machine, one no. of GI pipe 150mm long shall be fixed at the side of the CTB for drawal of jumper wires from point machines/lever locks with proper fixing arrangements. The CTB should be provided with EWS lock.

15.4.3 CT Box shall be painted with Aluminum paint and rails/L-angles with black paint. The circuit particulars shall be painted neatly on the CT Box cover and the location number have to be painted in „BOLD“ letter.

15.5 SHIFTING OF APPARATUS CASES/ CT BOXES:

The work consists of excavation of pit around the existing apparatus cases full/ half size and CT boxes, shifting of the location box along with foundation clear of infringement from the track. The pit shall be excavated with maximum care to avoid any possibility of damage to the existing cables.

The location box shall then be shifted carefully along with the foundation and cable termination, equipment etc., without disturbing the wiring. While shifting apparatus cases of full size, the brick wall covering the cables shall be broken before shifting the location box. After the location box is shifted, brick masonry walls shall be constructed on the front and back sides of the location box foundation. River/M-sand sand shall be filled up to the floor of the location and the bottom shall be sealed with sealing compound.

15.6 CABLE TERMINATION IN APPARATUS CASES/CTB's:

- 15.6.1 At each apparatus case/CTB, the work consists of fixing all cables, fixing of Phynolic synthetic industrial fiber base fine weave cotton fiber sheet - 6mm thick to IS specification 2036 - 1995 - Type board along with terminal blocks and termination of cables/cores (conductors) using PVC/ Nylon sleeves as per details of termination in approved location diagrams. The contractor shall prepare cable termination and wiring details of apparatus cases and C.T. boxes and obtain the approval of the K-RIDE/ Railway Engineer before execution as per the approved cable plan.
- 15.6.2 The underground signaling cable-main, tail and power shall be properly secured by wooden clamps of 50mm x 50mm teak wood inside apparatus case on 25mm x 100mm base plank. The cables shall be neatly skinned duly mending and taping of cable ends for termination bunched and terminated on the terminal board at the required place in order as per approved apparatus case circuit diagram. All the aluminum power cables of size 10 Sq.mm and above shall be provided with Aluminum lugs using crimping tool of appropriate size.
- 15.6.3 K-RIDE will indicate approximate total number of cable core, terminations to be made in the apparatus cases/cable termination boxes. The contractor shall fix Phynolic synthetic industrial fiber base fine weave cotton fiber sheet - 6mm thick to IS specification 2036 - 1995 - Type F5 sheet as required by Railway. Terminal blocks with links, fuse blocks with fuse shall be fixed on the terminal board pertaining to each apparatus case and cable termination box using proper size of wood screws. Two suitable holes shall be made on either side of terminal block and fuse block for bringing cable for termination. Termination of main cables, tail cables, power cables, core/cores shall be made at the proper terminal as per approved wiring diagram pertaining to each apparatus case and C.T. Boxes. Before final termination, each cable shall be tested for continuity, insulation etc. and readings recorded and jointly tested and signed.
- 15.6.4 As per site conditions, the termination of new cables may be required on the existing terminal blocks or by fixing new terminal/fuse blocks in old apparatus cases which shall be done as per approved circuit diagram wherever required. The terminal particulars are to be re-painted or corrected on the doors of apparatus cases as instructed by K-RIDE. Suitable clamping arrangements have to be made for the new cables and also the bottom the opening of the apparatus cases shall be closed with masonry brick work and sealed with cable compound.
- 15.6.5 After fixing all the signaling cables inside the apparatus case, the side opening shall be closed with masonry work and plastered. The inner side is filled with Sand and finally the bottom is sealed with sealing compound.
- 15.6.6 All the underground cables shall be provided with punched name plates showing total no. of cores, cross section of each core, Aluminum or copper conductor and from and to details etc. and also painted inside each apparatus case.

15.7 WIRING OF SIGNALS/ LC GATE CONTROL/ TRACK CIRCUIT/ POINT CONTROL RELAYS IN LOCATIONS:

- 15.7.1 Relays, transformers, heavy duty contact relays and other gadgets controlling the above functions shall be firmly fixed on suitable relay frames using MS Angles of size 25mmx25mmx6mm and MS Flats of size 25mmx6mm inside respective apparatus cases. The MS relay frame shall be painted before fixing. Hylum sheet of 25mm thick of requisite size shall be fixed inside the apparatus case for fixing Resistance and Electrolytic condensers. In case of shelf type relays, the relays shall be mounted on shelf planks with suitable anti- tilting arrangement. If plug in

type relays are used, 16/0.2mm flexible copper wire shall be used for wiring. For shelf type relay and point motor circuit, 3/0.75mm copper wire shall be used. There shall be no joint in the wire. For soldering the wire to relay clips of Plug-in-type relays in relay racks, best quality rosin core solder and temperature-controlled soldering irons shall be used. The complete wiring shall be tested jointly and linked to tail cable.

15.7.2 The description of all relays, fixed in each apparatus case shall be painted inside apparatus case doors. PVC/ Nylon sleeves shall be provided on each wire before termination on terminal block. The name of the circuit and wire where connected shall also painted on the sleeves.

15.7.3 Wire should be soldered to relay clips and suitable copper eyelets crimped with crimping tools shall be adopted before the termination. The wiring and termination shall be carried out as per the approved circuit diagram. The relays details shall be painted. PVC/Nylon sleeves shall be provided for each wire before termination and the details of circuit and where the wires connected etc., shall be painted on the sleeves. The complete wiring shall be tested.

15.8 **ALTERATIONS TO PAINTING PARTICULARS AT LOCATION BOXES:**

Consequent to introduction of new circuits or alterations to existing circuits in apparatus cases/ CTB"s, new nomenclature should be painted on the cable sleeve. And also the new particulars should be painted on the inner side of the doors at apparatus cases/ CTB"s.

15.9 **FILLING OF EARTH AROUND LOCATIONS:**

The work consists of filling of earth around the foundations of signals and apparatus cases for a width of 0.5m on all sides from 150mm below the foundation top to ground level. The earth shall be consolidated after filling.

16. **MAIN SIGNALS:**

16.1 **CASTING OF COLOUR LIGHT SIGNAL FOUNDATION:**

16.1.1 The work includes excavation of pit and casting of color light signal foundations with M.S foundation bolts as per Drg. No. SG/CN/02/9. The position of signals will be indicated by K-RIDE.

16.1.2 The Signal should be casted using Hylum sheet/ Waterproof Plywood/ MS sheet Form work to ensure smooth exterior finish and avoid the additional plastering. Necessary earth work, shall be made around the signal foundation and sufficient earth work shall be made up to the required level in the normal terrain and the cable entries shall be closed as per the instructions of K-RIDE/ Railway Representative at Site.

16.2 **ERECTION AND WIRING OF SIGNALS:**

16.2.1 Signal pole shall be securely fixed to surface base and erected on signal foundation and plumbed. The gap between the signal pole and surface base shall be filled with suitable putty to avoid tilting. Soon after installation, the pole shall be painted with two coats of Aluminum paint/
Yellow & Black strips of Enamel paint for second distant signal after a coat of primer. Signal unit shall be provided with two coats of black enamel paint.

16.2.2 Multi-unit color light signals up to 4 aspects shall be properly mounted on the top of signal pole where there is no route indicator. If required, LED type signal aspect shall be fixed for signals. If there is route indicator a large off set bracket shall be fixed firmly with 2 nos. of `U' bolts 3/4" thick on the signal pole for mounting multi-unit color light signals. One 22mm through hole shall be drilled on signal pole just below the off-set bracket and a 20mm through bolt shall be the provided to prevent offset bracket from sliding down.

- 16.2.3 Signal ladders with platform complete fittings, cast iron shoe and adequate number of support to suit signal pole 3.6/4.6m, shall be firmly fixed clear of infringement with suitable bolts and nuts and painted in black. The ladder shoes shall be concreted. This work also includes fixing of marker boards, enameled number plates with suitable clamps at the required place. Speed board if any, shall be fixed on the pole with proper clamp clear of infringement as required by K-RIDE.
- 16.2.4 Signal tail cable shall be taken through the signal pole without damaging insulation and armor, skinned and terminated on signal units. If the signal units are mounted on large offset brackets a vertical slotted hole of 50mmx50mm in size shall be made on signal pole for taking signal tail cable. Suitable protection shall be provided on the slotted hole to avoid damage to insulation of cable.
- 16.2.5 This work includes fixing of LED Unit along with Current Regulator. Wiring to be done according to approved circuit diagram. The unwanted aspects shall be blanked using MS sheets of 3mm thick.
- 16.2.6 All the multi-unit color light signals shall be wired with 3/0.75mm copper wire and terminated. For each aspect 2 separate wires shall be used from the terminals and the wiring shall be tested jointly.

16.3 **BLANKING ARRANGEMENTS FOR SIGNALS:**

In case of signals with a horizontal clearance between 2.21m and 2.36m (in B.G) from the nearest track centre, blanking arrangement shall be provided. If a Ladder of signal erected at a distance within 2360 mm from C/L of adjacent track then it should be blanked off (strap around by a sheet around ladder) to a height of 300mm between 2060mm and 2360mm above rail level using MS plate not less than 8mm thick. The end portions of the plates should be folded and made smooth so that it will not harm the person climbing the ladder. This plate shall be painted with black.

- 16.4 All signals shall be properly earthed in RE area.
- 16.5 Necessary wooden cross shall be fixed on the newly erected signals before being brought into use.

16.6 **ROUTE INDICATORS:**

- 16.1.1 All types of Route Indicators shall be mounted on the top of signal pole firmly. The tail cables for route indicators shall be taken through signal pole without any damage to the insulation and armor, skinned and terminated on route indicators. Route indicators shall be wired with Wire PVC 3/0.75mm copper as per the approved circuit diagram. Hoods shall be fixed properly and examined during day time and if required extension of hoods shall be made to have proper visibility. The route indicators shall be painted as required by Railways.

16.1.2 **Universal AC/DC LED Numeric Route indicator**

- 16.1.2.1 Universal AC/DC LED Numeric Route indicator should be capable of displaying 1 to 19 route with right & left arms with optical sensing and complete housing for use with LED ECR.
- 16.1.2.2 The unit should mount at the top of signal post safely and securely. Necessary fixing arrangements shall be supplied by Contractor.
- 16.1.2.3 The circuit should be so designed that it draws the required current to ensure the pickup of ECR whenever the digit is lit.
- 16.1.2.4 RDSO approved Route LED"s should be used for left and right arms. It should work on 110V +/- 20% AC.
- 16.1.2.5 Color of LED"s of white color of reputed make should be used for Numeric Route indicator seven segment display. Fusing of an LED should neither blank the whole segment nor deteriorate the visibility of indication. Uniform intensity over entire operating range Components used in numeric route indicator unit should be industrial grade.

- 16.7 **CALLING - ON SIGNALS/'A' MARKER LIGHTS:**
Calling on signals/'A' marker shall be fitted on the signal posts at required height using off-set bracket. Suitable hole shall be drilled on the signal poles to bring the cable/jumper wires. The cable/jumper wires shall be taken to calling on signal/ „A“ marker through suitable steel hose pipes and wired by using 3/0.75mm copper wire. The calling on signals shall be provided with `C' marker and „A“ for „A“ marker. Number plates to be fixed and painted as per the standard practice in this Railways.
- 16.8 **REPLACING THE TAIL CABLES IN SIGNALS:**
Wherever necessary the existing tail cables shall be released from the existing signals and new tail cables shall be drawn to the aspects and terminated. The termination particulars shall be painted.
- 16.9 **SHIFTING OF SIGNALS:**
Wherever required the existing Colour Light Signals shall be shifted to clear any infringement from the tracks as instructed by K-Ride/ Railway representative at site. The earth surrounding the foundation shall be excavated and the cable coils shall be loosened very carefully without causing any damage to the cables. The Signal shall be moved along with the foundation slowly to the new position and earthwork shall be done around the foundation. The loosened cables shall be buried at 1m depth.
- 16.10 **REPLACEMENT OF SIGNAL UNITS:**
The existing CLS units shall be removed from the signal post duly disconnecting the cables and new signal units (required as per signalling plan) shall be mounted on the existing signal pole. The tail cable is to be terminated and the signal aspect shall be wired by providing LED unit with Current regulator. If there are any blank aspect, the same shall be covered with round MS plate.
- 16.11 **SCREENING ARRANGEMENTS:**
For the Colour Light signals in RE area which are coming in the infringing zone, screening arrangement as per standard RE drawing shall be provided as required by Railways. The screen made of MS wire-mesh will be fixed on MS angles of size 25x25x6mm with suitable fixing clamps, bolts and nuts and finally painted with black.
- 17. SHUNT SIGNALS:**
- 17.1 **POSITION LIGHT GROUND TYPE SHUNT SIGNAL:**
- 17.1.1 The work involves excavation of pits and casting of shunt signal foundations as per Drg. No. SG/CN/02/10. The position of shunt signals will be indicated by the K-RIDE. Foundation for shunt signals shall be casted with cement concrete in the ratio 1:3:6 using stone jelly of size 20/25mm. The foundations are to be plastered on all sides. Necessary earthwork shall be made for each position light shunt signals as required by the K-RIDE.
- 17.1.2 The position light shunt signal shall be properly mounted and plumbed.
- 17.1.3 The cables are to be taken through the unit, skinned and terminated. The post type/Ground type shunt signals shall be wired and terminated and the wiring shall be tested jointly.
- 17.1.4 This work includes fixing of number plates and direction Arrow plates. The post shall be painted with Aluminum while the signal unit and surface base with black enamel paint.
- 17.1.5 The CLS units, Route Indicators, Calling-on signals, position light shunt signals post type and ground type shall be provided with EWS locks.

17.2 POST TYPE SHUNT SIGNAL:

Small off-set bracket shall be firmly fixed with 'U' bolts of suitable size on signal pole for mounting Post type shunt signals. One 22mm through hole shall be drilled on signal pole just below the off-set bracket and a 20mm through bolt shall be provided to prevent offset bracket from sliding down. A vertical slotted hole of 50x50mm in size shall be made on signal pole for taking the signal tail cable. Suitable protection shall be provided on the slotted hole to avoid damage to insulation of cable. The cables are to be taken through the unit, skinned and terminated. The post type/Ground type shunt signals shall be wired and terminated and the wiring shall be tested jointly. This work includes fixing of number plates and direction Arrow plates. The post and signal unit shall be painted with Aluminium and enamel black respectively. One EWS lock shall be provided for the signal.

18. TRACK CIRCUITS:

18.1 INSTALLATION:

- 18.1.1 The work includes drilling of holes, bonding of rail joints with 8 SWG GI soft solid wire. 7.2mm holes are to be drilled close to Fish Plates on the web of rail and the bond wires are to be fixed by driving channel bond pin tightly. Two bond wires are to be provided for each joint in parallel. One bond wire clip is to be provided for each joint to keep the bond wire intact. In point track circuit, parallel jumpers/ bond wires/cables shall be provided as required by the K-RIDE/Railways with proper supporting arrangements.
- 18.1.2 Four TLD boxes, two each at track feed end relay end shall be fixed clear of infringement and the respective track circuit tail cables 2 x 2.5 sq.mm PVC copper conductor from the apparatus case shall be terminated in these boxes.
- 18.1.3 In Point zones, additional TLD boxes shall be provided for series jumpers as per the bonding plan and instruction of K-Ride representative at site. The connection from the TLD boxes to the rail should be through 8 SWG GI soft solid wire which should be taken through PVC sleeve or signalling cable if required and fixed to the rail both at feed and relay ends. The GI Wire should be clipped on to the sleepers to prevent shorting with rails.
- 18.1.4 Wherever Glued joints are not provided, Rail Joint insulation RDSO type shall be provided with long bolts and nuts at places marked by K-RIDE/Railways. In case of point zone track circuit, necessary insulation shall be provided for switch extension pieces/„D” brackets, throw bar lugs, gauge tie plates, crossing plates, stretcher bars, etc., as per site conditions and fixed by the contractor in the presence of K-Ride representative. Insulating material shall be provided by contractor. Contractor shall use proper MS washers, bolts and nuts for insulating them. All the insulation shall be tested jointly. Wherever the Roding crosses track circuit zone, it shall be provided with rod joint insulation and tested.
- 18.1.5 Polarity bonding in each point track circuits shall be provided using 8 SWG soft wire, insulated and clipped on to sleeper. Parallel bonding shall be done wherever required. In RE area transverse bonding should be provided at both feed and relay ends by connecting 2GI 8SWG wire across the block joint as per the bonding plan.
- 18.1.6 Track circuit work includes fixing of track feed and track relay equipment in the apparatus cases as indicated by the Railway. The shelf type track relay shall be provided with suitable anti-tilting arrangement. Track relay details shall be painted on the inner side of the apparatus case door.
- 18.1.7 Suitable flexible copper wire shall be used for wiring the track relay, track feed equipment, batteries, chokes, etc. and finally terminated at the terminal block. For each track circuit, secondary cell 80 AH shall be charged and installed in the apparatus case. The no. of cells and chokes to be used for each track circuit will be as

instructed by the Engineer in charge. The secondary cells shall be charged by the contractor through reputed agencies. The charging of secondary cells shall be done as indicated in following paras below.

18.1.8 All the TLD boxes shall be painted and Track Circuit numbers along with feed end or relay end particulars shall be neatly painted as required by K-RIDE/Railways.

18.2 ALTERATIONS TO TRACK CIRCUIT:

18.2.1 Alterations to the existing track circuits involves by shifting the Feed end equipment/ Relay end equipment/block joints and installing them at a different location and re-wiring them.

18.2.2 After completing the installation/alteration of track circuit, it shall be energized, tested, adjusted and readings recorded in track test record.

19. POINT MACHINES:

19.1 INSTALLATION OF POINT MACHINES

- (i). Electrically operated point machines shall be fitted in level to all facing points as per standard drawing on long sleepers on extended gauge-tie plate, clear of infringement.
- (ii). The point machine shall be installed after cleaning the machine (both inside and outside) and greasing/oiling of all the moving parts. The point machines shall be hand operated, detection and motor controlling contact adjusted before taking to site. All unwanted openings shall be covered with MS Sheets.
- (iii). The point machines shall be fixed with proper size of bolts and nuts and flat/spring washers with correct size of holes on special sleepers to avoid lateral play.
- (iv). All point connecting rods shall be connected to point machines as per standard layout/drawings without any strain and with minimum offset. All connecting rods shall be in level and correct size of pins shall be used to avoid longitudinal play. Any changes in the connecting Roding during installation which necessitates welding and off sets shall be carried out by the contractor at site. The welding shall be by smithy process. Lengthy roddings shall be supported suitably.
- (v). Suitable eyelet shall be used for termination of power cables using Crimping tool. The jumper wires from the point machines to the CT boxes shall be taken through flexible conduit PVC pipes and securely fixed with suitable clips. The wiring inside the point machine for motor and detector circuit shall be tested for insulation and earth and the connections tightened. 7/1.4mm 3/0.75mm PVC copper wire shall be used for wiring point machines. PVC/Nylon sleeves shall be used for identification of cable cores/jumper wires and marked with paint. Necessary grooves/wards shall be cut on the point machine at the place of insertion of crank handle, for crank handle interlocking purpose.

19.2 ADJUSTMENT AND TESTING OF POINT MACHINES:

19.2.1 The point machines shall be worked by hand crank and the housing of switch rail with the stock rail shall be checked. All the electrical wiring shall be carried out neatly.

19.2.2 The point machines shall be worked both ways with proper feed. It should work without undue friction and working current shall be recorded.

19.2.3 The point stretcher bar and lock connections should be adjusted in such a way that with a 5mm thick obstruction piece placed between the switch and stock rail at 150mm from the toe of switch,

- (a) The point does not get locked.
- (b) The point detection circuit is not completed
- (c) The friction clutch disengages.
- (d) The tripping current does not exceed 200% of normal working current.

- 19.2.4 The point machine shall be provided with EWS locks/pipe locks.
- 19.2.5 Necessary notches shall be cut on the pinion of point machine to suit crank handle configuration in the case of 5E only.

20. CABLE TERMINATION RACK:

- 20.1 Cable termination racks shall be erected in the relay room at the required location as per the approved Relay room floor plan and shown by the K-RIDE with suitable foundation bolts and cement concreted. The cable termination racks shall be painted soon after installation but before cable termination work is taken up. Suitable cable ducts wherever required shall be provided to bring all outside cables to the termination rack.
- 20.2 All the cables are to be neatly skinned, fixed on the cable bracket and terminate in order. Bending of cables to less than 120 degree shall be avoided. The cable armors and the rack should be earthed. Internal wiring and termination particulars are to be written with paint. 6 way/1 way terminal blocks are to be fixed on Hylum sheet and held rigidly by mechanical screws.
- 20.3 **TERMINATION OF CABLES:**
- 20.3.1 The PBT terminal and fuse blocks shall be fixed firmly on the cable termination racks and serially numbered with paint for easy identification. Tags shall be provided for each terminals and painted, giving description of the circuit. Suitable rubber grommet shall be provided on the holes of termination racks. Copper tape of width 25mm x 1.5mm shall be used for providing bus bars. Suitable holes shall be drilled in copper tape for this purpose.
- 20.3.2 All the cables shall be identified by a punched label, tied on to each cable. Printed cable termination index and pasted on Perplex sheet of thickness 10mm as per instructions of site in- charge shall be fixed in the relay room showing the terminal numbers circuit-wise. In case sufficient space is not available for fixing the board in one piece, it may be provided in parts retaining the overall size as per instructions of site in-charge. 'As made' terminal particulars shall be prepared in tracing Film duly signed and handed over to the K-Ride at the time of commissioning.

21. RELAY ROOM:

21.1 ERECTION OF RELAY RACK :

- (i). Relay rack shall be erected as per the SWR standard practice.
- (ii). The relay rack shall be painted including Relay nomenclature as per relay disposition chart soon after the installation and before plugging of relays.

21.2 WIRING OF RELAYS(NEW/ ADDITIONAL/ ALTERATION):

- (i). Based on the circuit diagram, contact analysis chart shall be prepared by the contractor. The required number of 50 way terminal boards, plug boards and plug in type relays shall be fixed on the new/ existing rack in the nominated places as instructed by K-Ride representative. The configuration of plug boards should be checked with the contact analysis chart. The nomenclature both on the rear and the front side of the plug board and on front side of the relays in the relay frame shall be painted.
- (ii). Suitable arrangements shall be made in the relay rack for fixing condenser and resistance unit, required for slow to pick up or slow to release feature. Letter painting shall be made against each unit to identify the circuit for which it is used. Suitable wire supporting Tray made of PVC shall be provided for each row in relay rack to accommodate the complete bunch, wherever the new wiring is carried out.

- (iii). The wiring shall be carried out as per approved circuit diagram. The wiring shall be done on connectors and terminated on terminal clips by soldering process neatly, using high grade solder and Temperature controlled soldering iron. PVC flexible wire 650V grade 16/0.20mm copper conductor shall be used. Potential free contacts of various relays required to be monitored by the Data logger should also be wired on the tag block of the data logger using distinct colour wire. In case of alteration to existing wiring, the wires and relays not required shall be removed. After completing the alteration work, the new wires have to be bunched neatly and brought to original condition. The relay rack wiring shall be tested initially by the contractor and then jointly with K-Ride Representative. Any addition/alteration to wiring in the course of testing shall be carried out free of cost by the contractor. Different colours of wire shall be used for identify the power supply circuit wiring. In case of alteration, a different colour of wire from the existing one shall be used for easy identification.
 - (iv). Before plugging, the relays shall be checked visually and defective ones noticed shall be replaced duly reporting the same to the K-RIDE/Railways.
 - (v). The printed Relay Index and pasted on Perpex sheet of thickness 10mm as per instructions of site in-charge shall be fixed in the relay room in the relay room giving the details of the relays and their position in the relay rack. In case of alteration/additional relay wiring, the relay particulars shall be incorporated in the existing relay index board available in the relay room. If sufficient space is not available for fixing the board in one piece, it may be provided in parts retaining the overall size as per instructions of site incharge.
 - (vi). Rubber mat having sufficient width should be placed in front and rear of all the relay rack and FTOT. The mat should not be less than 6mm thick and it should withstand 650V AC.
- 21.3 Relay rack to relay rack wiring shall be done with 16/0.2mm PVC copper conductor by soldering process.
- 21.4 The inter-connection between the relay rack and power room, power room and FTOT, Block Instruments and FTOT shall be carried out with underground, armoured, sheathed, power/ signalling cables of adequate length. The termination shall be carried out using suitable size of copper eyelets/sockets. Inter-connection between power rack and battery room, shall be carried out by using suitable underground cables.
- 21.5 All the interconnecting wires shall be supported by means of Aluminium ladder. Ladder of suitable capacity shall be manufactured using Aluminium angles of size 50mmx50mmx6mm and Aluminium flats of size 25mmx6mm. The inter spacing between two rods of the ladder shall not be more than 125mm. The corners of the ladders as well as the inner path of the ladders shall be of curved shape and shall not damage the insulation of the inter-connection wire. The bends also shall not be steep. The bottom of the ladders shall be provided with Hylum sheet of 3mm thickness. The ladder shall be fixed firmly with proper Aluminium flats.
- 21.6 The inter connection arrangement includes laying of signalling cables in ducts, wherever necessary as indicated by K-RIDE/Railways. Wherever cables are taken through cable ducts inside relay room/ battery room etc., the ducts shall be filled with River/ M-Sand sand up to the floor level and covered with RCC slabs covered with suitable tiles.

- 21.7 All connections/ terminations shall be tested by the contractor and after satisfying himself jointly with K-Ride Representative. Any alterations required shall be carried out by the contractor free of cost.
- 21.8 Cable details, functions allotted to each core and terminal numbers shall be prepared in standard size tracing film and handed over to K-RIDE.

22. POWER SUPPLY ARRANGEMENT:

22.1 INSTALLATION IN POWER ROOM:

- 22.2 The contractor shall manufacture a power supply panel using 1200x1200mm Hylum sheet not less than 10mm thick for mounting meters, switches/fuses, etc. as required by K-RIDE/Railways. It shall be installed on a frame made of MS angles of size 25x25x6mm, MS flat of size 50x6mm and grouted to the wall after leaving sufficient space from the wall for testing and replacement. The cable shall be fixed on TW base plank of size 25x150mm using TW cable clamps of size 50x50mm and terminated on PBT Terminal blocks.
- 22.3 The power supply arrangements wiring shall be carried out using 7/1.4 mm PVC Copper wire as per the approved circuit diagram.
- 22.4 Ammeter and Stabilizer by-pass arrangements shall be provided on the panel to prevent ammeter being always in the circuit. After wiring, the power rack shall be tested jointly. The power rack shall be energised to its rated capacity and kept in that condition for not less than a week before commencement and any defect notice shall be rectified by the contractor. The Guarantee Certificates and Technical Pamphlets for the power supply equipments shall be handed over to K-Ride. Any addition/alteration to power supply arrangement shall be carried out during Testing and Commissioning.
- 22.5 The power rack and power supply equipment shall be painted suitably and uniformly before installation as required by K-Ride/Railways. Schematic diagram of power supply arrangement and distribution details shall be printed and pasted on 10mm thick perplex sheet as per instructions of site in-charge and fixed in the power room. As made power diagram shall be submitted in tracing film duly indicating the power supply details and position of the equipment's.
- 22.6 The power panel and power rack should be suitably earthed.
- 22.7 **INTEGRATED POWER SUPPLY ARRANGEMENT**
This work involves erection of Integrated Power Supply (IPS) units conforming to RDSO Specification No.RDSO/SPN/165/2012 Version with latest amendment as required by Railways and wired.

23. INTERLOCKING OF LEVEL CROSSING GATES WITH LIFTING BARRIERS:

- 23.1 Excavation of pit, concrete foundation as per Drg.No.SG/CN/ 11 and erection of ground lever frame using suitable bolts and nuts. Casting of A type foundations for mounting the cranks is included in the scope of this work. All the foundations will be plastered on the top.
- 23.2 Making rod connection from the Ground lever frame to the boom locking mechanism through cranks, adjusting and testing the boom locking from ground lever frame. The rod run shall be at rail level and gap of not less than 40mm shall be maintained while crossing the track. All the joints of rod connecting cranks and levers shall be smithy welded. The rod run between the track shall be insulated while crossing the track circuited portion The Lengthy roddings shall be run on roller stands fixed on trestle located not more than 2.2 Meters between adjacent supports.
- 23.3 The gate interlocking arrangement shall be carried out as per the standard practice of S.W. Rly and as per the instructions of the K-Ride representative at site.
- 23.4 The lifting Barrier will be painted with two coats of enamel paint of approved quality as given below:
- (A) Stands: Black
 - (B) Boom with fringes: Black and Yellow- Retro-Reflective stripe 300 mm wide alternatively
 - (C) Stop Disc on the boom: Red- Retro-Reflective
- 23.5 Florescent paper strips should be pasted on both the lifting barrier boom.
- 23.6 **INSTALLATION OF ELECTRONIC GATE WARNING EQUIPMENT:**
The work includes fixing of Gate warning equipment on suitable fixtures as per Railway standard for LC gates - 2 Nos. one on each side of the track, fixing of amplifier in apparatus case and hooter at Road warning signal post, wiring as per approved circuit diagram and painting.
- 23.7 In RE area wire rope and Roding shall be insulated with proper insulating material and all metallic parts shall be connected to earth. Insulation required for wire rope and Roding insulation shall be supplied by the contractor.

24. INSTALLATION OF Key-Lock Checking Relays:

Supply and Installation of Pre-wired Crank Handle Cum Key Lock Relay Box (of MS Sheet) along with LEDs, with approved type push buttons, Wago or similar Disconnecting type Terminal Blocks including DIN rail etc., as per standard practice of SWRly. Installation, fixing and wiring of boxes for Key Lock Relays to be carried with Contractor's wiring and fixing material. The work shall be carried as per the instructions of K-RIDE Engineer. Provision for KLCR Termination of Cables on Wago Terminals and Installation to be carried out as per the Item Description in the Tender Schedule and as per the direction of K-RIDE Engineer/Representative.

25. INTERLOCKING OF LEVEL CROSSING GATES WITH LIFTING BARRIERS:

- 25.1 Excavation of pit, concrete foundation as per Drg.No.SG/CN/ 11 and erection of ground lever frame using suitable bolts and nuts. Casting of A type foundations for mounting the cranks is included in the scope of this work. All the foundations will be plastered on the top.
- 25.2 Making rod connection from the Ground lever frame to the boom locking mechanism through cranks, adjusting and testing the boom locking from ground lever frame. The rod run shall be at rail level and gap of not less than 40mm shall be maintained while crossing the track. All the joints of rod connecting cranks and levers shall be smithy welded. The rod run between the track shall be insulated while crossing the track circuited portion The Lengthy roddings shall be run on roller stands fixed on trestle located not more than 2.2 Meters between adjacent supports.
- 25.3 The gate interlocking arrangement shall be carried out as per the standard practice of S.W. Rly and as per the instructions of the K-Ride representative at site.
- 25.4 The lifting Barrier will be painted with two coats of enamel paint of approved quality as given below:
- i) Stands: Black
 - ii) Boom with fringes: Black and Yellow- Retro-Reflective stripe 300 mm wide alternatively
 - iii) Stop Disc on the boom: Red- Retro-Reflective
- 25.5 Florescent paper strips should be pasted on both the lifting barrier boom.
- 25.6 **INSTALLATION OF ELECTRONIC GATE WARNING EQUIPMENT:**
The work includes fixing of Gate warning equipment on suitable fixtures as per Railway standard for LC gates - 2 Nos. one on each side of the track, fixing of amplifier in apparatus case and hooter at Road warning signal post, wiring as per approved circuit diagram and painting.
- 25.7 In RE area wire rope and Roding shall be insulated with proper insulating material and all metallic parts shall be connected to earth. Insulation required for wire rope and Roding insulation shall be supplied by the contractor.

26. ELECTRIC KEY TRANSMITER AT LC Gate/ STATION HOUSE:

- 26.1 Electric key transmitter with/ without crank handle fixed to the key shall be installed firmly on suitable angle supports and Hylum sheet boards in the place indicated by K-RIDE/Railways, with economizer push switch and wired. The cables shall be terminated on a terminal box made using 25mm thick T.W. planks and locking facilities. Required number of terminal blocks shall be fixed inside the terminal box for termination of cables and jumper wires. The wiring shall not be exposed. The cables shall be taken to the terminal box using Powder coated MS Box of suitable size. Interlock the EKT key with Crank handle by Nickel coated Dog chain/ welded. The EKT should be painted and the circuit particulars and ward nos. are to be painted in bold letters.

26.2 INSTALLATION OF EMERGENCY KEY PROVING CONTACT:

EKT shall be kept in a glass fronted wooden box and wired. The box shall have the locking and sealing facility using 6 levers NAVTAL LOCK with duplicate keys.

The contacts shall be made when the key is 'IN' and contacts shall break when the key is disturbed or taken 'OUT' using a limit switch.

NOTE: In case of Crank Handle Interlocking using Key-Lock Checking Relays, Provision for KLCR/Crank Handle Box, Termination of Cables on Wago Terminals and Installation to be carried out as per the Item Description in the Tender Schedule and Drawing enclosed here.

27. INTERLOCKING OF SIDING POINTS/ TRAP POINTS:

- 27.1 For siding points with succession key lock arrangements and trap points, hand plunger lock fitted with "E" type locks shall be provided on gauge tie plates with suitable bolts and nuts. This work includes fixing of switch extension pieces and split stretcher bars. Notches on split stretcher bars shall be cut at site.
- 27.2 It shall be ensured that, it is not possible to lock the points with an obstruction of 5mm test piece placed between switch and stock rail at 150mm from the toe of the switch.
- 27.3 'E' type lock shall be fitted to the hand plunger locks with proper bolts and nuts. After ensuring the free as well as the full movement of the plunger, marking shall be done and notches cut on the plunger.
- 27.4 Proper lubrication shall be done for the smooth operation of points, HP locks and 'E' type locks.

28. TELEPHONES:

28.1 DESK TYPE PHONES AT STATION HOUSE/APPARATUS CASES/LCs:

Desk Type magneto telephone shall be supplied and fixed at station house/ apparatus case/ LCs/ apparatus cases near top points/siding points and securely fixed on shelf planks. It shall be ensured that no other gadgets are kept in that apparatus case and separate door lock arrangement made to protect the Telephone battery.

Nickel-Cadmium power pack 4V - 2.2AH, with battery charger 110V AC/4V DC shall be supplied and provided for telephone.

29. PROVISION OF TEAK WOOD KEY BOX & TOOL BOX:

- 29.1 This work involves manufacture, supply and installation of Glass fronted Teakwood Key box of size 300mmx600mmx75mm with built in lock arrangement. Plastic tags duly engraved giving the particulars of various keys are to be provided along with the keys.
- 29.2 A teak wood tool box of size 1000mm x750mm x100mm (inner dimensions) made of 25mm thick teak wood, perplex sheet fronted 6mm(Color-less) shall be manufactured and fixed on the wall at a convenient location as instructed by K-Ride representative at site. The box should have provision of padlock for locking arrangements.

30. ERECTION OF BOARDS WITH LEGENDS/ GOODS WARNING BOARDS:

- 30.1 Retro reflective Boards with Calling on Legends/ Goods Warning boards shall be fitted on to the Rails/L-Angles, erected with suitable foundation at location as indicated by K-Ride representative and as per approved signaling plan, clear of infringements.
- 30.2 Necessary legends such as "DRAW CLOSE IF SIGNAL IS AT ON" shall be computer printed on retro reflective sheet as per standard practice of this Railways and as per Signal Engineering Manual.
- 30.3 Rail posts and other fittings shall be painted as prescribed in Signal Engineering Manual and as directed by K-RIDE/Railways Engineer.

31. EARTHING:

31.1 All apparatus cases, battery boxes, CT boxes, armors of cables, battery chargers, transformers, power panels, Control panel, Block Instruments/Control test panel/Cable Termination Rack/Relay Racks, etc., shall be earthed. If number of apparatus cases are grouped at a place, one earth shall be provided up to 2 Full Locations and 1 Half Location. Over and above this, additional earth to be provided at the other end and both the earth need to be connected to all the locations in ring path. Otherwise, separate earth is to be provided for each apparatus case. The earth resistance shall not be more than 10 Ohms.

31.2 GI PIPE EARTHING SYSTEM shall be provided as per the drawing of GI Pipe Earthing system available at K-RIDE and as directed by Railways Engineer.

31.3 COPPER PLATE EARTHING SYSTEM shall be provided as per the drawing of Copper Plate Earthing system available at K-Ride and as directed by K-RIDE/Railways Engineer.

32. PROVISION OF LOCKS:

Universal locks (EWS Locks)/ GI locks/Navtal Locks shall be provided for CLS units, Route Indicators, point machines, apparatus cases, battery boxes and C.T. boxes, wherever necessary. Two Navtal locks (Godrej make) 75mm with 2 keys shall be provided for Relay Rooms at all stations.

33. PAINTING:

33.1 Block instruments, Block counters, control panel, EKT"s and all signaling gears installed shall be painted in accordance with the standard practice of South Western Railway and as per Signal Engineering Manual.

33.2 While painting, initially one coat of primer and afterwards 2 coats of enamel/aluminium paint shall be applied.

33.3 The details of paints to be used on the signaling gears are shown below.

S. No.	Signalling Gadgets	Colour to be painted (outside)
I	Signal(Colour Light Signal) & Shunt Signal: i) Surface base ii) Post iii) Aspect unit complete	Black Aluminium(except for Distant Signal in Double Distant Territory) Black Note: Post of Distant Signal in Double Distant Territory to be painted in black & yellow stripes at 300 mm interval.
II	All types of apparatus cases and cable termination box	Aluminium
III	Track Lead Disconnection Box	Black
IV	SM"s Control Frame Instrument	Green Enamel
V	Point machines	Black
VI	Electrical Detectors	Black
VII	Electrical Lever locks & Circuit Controller	Black
VIII	Key Transmitters	Red or Black
IX	(i) Double line SGE Block Instrument (ii) Single Line Token Instrument (iii)Single Line Tokenless Instrument	Green Enamel Grey Enamel Green Enamel
X	(i) Interlocking frame supports, quadrants, lever below quadrants, locking trough, catch handle connection & Indication plates (ii) Down rods between Lever tail and crank (iii) All types of cranks, compensators, Facing point Locks, lock bars & Detectors. (iv) Roddings & Rod Rollers	Black Black Black Red Oxide Paint
XI	(i)Point Lever (ii)Lock Lever (iii)LC Gate Control Lever (iv)Spare Lever (v)Signal Lever	Black Blue Chocolate White Red
XII	Rails	Black

34. NON-INTERLOCKED SIGNALLING ARRANGEMENT:

- 34.1 Non-Interlocked Signalling Arrangement as explained below shall be made by the Contractor at his own Cost during all the phases of Commissioning of Stations as per the directions of K-Ride representative. No extra payment will be made on this account.
- 34.2 Erection and wiring of temporary relay rack, SM's slide instrument, wiring alteration in the FTOT, apparatus cases, signals, Control panel etc. as per the instructions of K-Ride representative at site for operating signals and points during non-interlocked working.. The work also includes provision of Magneto Telephone communication between Top points/ location goomties and SM's Room.
- 27.3 The SM's control instrument shall be wired as required by K-RIDE/Railways and as per the circuit diagram prepared in connection with NI. working. Necessary wooden crosses shall be fixed for the signals out of use as indicated by K-RIDE/Railways. Special warning boards/stop/speed boards may be fixed temporarily as per the NI plan.

35. RELEASING OF S & T GEARS:

- 35.1 An inventory of all the S&T gears to be released in the yard should be taken up jointly with K-RIDE/Railways representative duly indicating as serviceable or unserviceable before NI working commences. The same should be submitted and approved by the Engineering in-charge.
- 35.2 The S&T gears as mentioned in the schedule should be released carefully without damage and stacked at a place indicated by the K-Ride representative.
- 35.3 All the concrete foundation of the released gears like signals, location boxes, „A“ type bases, etc. should be broken completely. The resultant pit shall be refilled with earth, rammed and re-surfaced. In case of releasing, the stands grouted on the walls/ floor should be restored to original condition and neatly plastered.
- 35.4 All the unserviceable released materials shall be guarded by the contractor till they are returned back to stores/ depot as directed by K-Ride representatives.

36. TRANSPORTATION OF SERVICEABLE MATERIALS:

The released serviceable materials shall be transported from the work spot to the Stores Depot. Loading and Unloading of materials shall be done by the contractor. The released material shall be stacked neatly by the contractor in the Railway Stores.

37. PROCUREMENT OF CEMENT:

- 37.1 Cement for use in the works shall be procured by the contractor from the main producers/their authorized dealers/ authorized stock yards which shall conform to BIS Specifications.
- 37.2 Cement bags packing should bear the following information in legible marking:
- i. Manufacturer's name
 - ii. Registered Trade Mark of manufacturer, if any
 - iii. Type of cement
 - iv. Weight of each bag in kgs. or No. of bags/ton.
 - v. Date of manufacturer, generally marked as week of the year/year of manufacturer, e.g., 30/93 which means of 30th week of 1993.

- 37.3 To ensure quality control, test certificates from the manufacturer should be produced by the contractors, which should confirm to the relevant specifications [latest may be incorporated].
- 37.4 K-RIDE/Railways may also take samples during the course of the work and get the cement tested to ascertain their conformity to specifications.
- 37.5 When such sampling is done, it shall be as per IS Specifications.
- 37.6 Test on the cement as per IS:4301 shall be carried out in the field level. Some of the tests

Which may be carried out are:

- (i) Compressive strength
- (ii) Initial and final setting time
- (iii) Consistency
- (iv) Soundness

38. WIRES TO BE USED IN S&T INSTALLATION:

The size of various wires/ cables to be used for the wiring of signalling and telecommunication gadget is indicated below:

SN	Size of wire	Circuits/ Equipments
1	16/0.2 mm Copper	Relay rack wiring Panel wiring Plug-in type relay wiring at location
2	7/1.4mm Copper	Power equipments
3	3/0.75mm Copper	Power equipments in locations Relays other than plug-in type Block instrument Rotary key transmitter All Signals Electrical detector SM"s control instrument Point machine Loop wire at locations

39. TESTING & COMMISSIONING INCLUDING AS MADE:

- 39.1 The entire installation shall be tested by the contractor as per the approved plan and design according to the provisions in Signal Engineering Manual (SEM), OEM guidelines and established practice of the railways and after satisfying himself, the K-RIDE / Railway shall jointly test along with the contractor. Any alteration during testing shall be carried out at free of cost as required by K-RIDE/Railways before commissioning. Each installation shall be tested in the presence of the supervisory officials deputed by the K-RIDE/Railways as soon as the particular installation/ equipment is installed and unless the working of the equipment is actually ensured, it will not mean that the work has been completed to the satisfaction of the K-RIDE / Railway. This work involves testing and commissioning of the entire installation. Two copies of the approved plans and designs

incorporating all construction details and stamped as "TESTING COPY" shall be submitted to K-RIDE before taking up the joint testing with Railways.

39.2 In order to ensure that equipments are properly installed and commissioned by adhering to pre- commissioning check list and procedure as defined by OEM in its installation manual, it is necessary that Electronic Signaling systems i.e. EI, SSDAC, IPS, Datalogger are installed, tested and commissioned by RDSO approved manufacturer and a certificate shall be issued to K-RIDE/Railways.

39.3 **"AS MADE" DETAILS:**

After joint testing of the installation with the K-RIDE/Railways engineers and incorporating all alterations suggested in the approved plan and design, the contractor shall update all the records, plans and design. Required copies of final 'As Made' details as hereunder shall have to be supplied duly incorporating all particulars for the station before commissioning of the entire installation. All „Asmade“ shall be prepared by the contractor in AutoCAD 2000 or latest and submitted in compact discs in duplicate. All 'As Made' documents/ plans shall be made by the contractor on Polyester Films to RAILWAY STANDARD only as laid down in the Special Condition of Contract and shall be handed over to the Railways, duly signed.

- i. „As made' Circuit Diagram
- ii. „As made' Cable Core Plan
- iii. „As made' Cable Route Plan
- iv. „As made' Track Bonding Plans
- v. „As made' Power Supply Layout Diagram
- vi. „As made' Contact Analysis Chart
- vii. „As made' Relay Disposition Chart
- viii. „As made' Termination Particulars of Locations & FTOT.

Contractor shall hand over along with the negatives, required copies of plans and designs in the neatly bound booklet marked as 'FINAL As Made'. Two sets of these documents shall be kept in thick plastic cover (2 sheets back to back in one plastic cover) duly filled in plastic folder and handed over to Railways.

The contractor is required to supply the following bound registers in 100 pages printed on good quality papers. (75 GSM)

- i. Cable Meggering Register,
- ii. Relay Register,
- iii. Relay Room Key Register,
- iv. Route Cancellation Register
- v. Earth Resistance Register.
- vi. Track Circuit Register
- vii. Points Machine Parameter Register
- viii. IPS Parameter Register
- ix. Battery Register,
- x. Axle Counter/MSDAC/ BPAC Parameter Register and any other Registers/Bounded Books as indicated by the K-Ride Representative.

40. PROCEDURE FOR INITIAL CHARGING OF SECONDARY CELLS:

- 40.1 All the cells in the battery set shall be same type and capacity.
- 40.2 Electrolyte shall be prepared by mixing battery grade Sulphuric Acid and distilled water in the ratio 1:5 in a glass/ Porcelain container by adding Acid to water and not vice-versa
- (i). The new cells shall be cleaned with distilled water and filled with this electrolyte up to 12-15mm above the plates
- 40.3 Allow the plates of cells to soak in the electrolyte for 12 hours
- 40.4 Charge shall be applied at the rate of 4% of AH value of the cells to the correct terminals of the battery set duly interconnected.
- 40.5 Specific Gravity and voltage of each cell shall be measured and recorded once in 8 hours.
- 40.6 Charging shall be stopped when specific gravity becomes 1210 +/- 5
- 40.7 If the specific gravity does not attain this value, little quantity of electrolyte shall be taken out and with electrolyte of higher value (1400 – obtained by adding acid and added water in the ratio 7:11) and charging shall be started afresh.
- 40.8 On charge, the cells shall be discharged with lamp load up to the limit when the specific gravity becomes 1190 and voltage 1.85 volts.
- 40.9 Charge and discharge cycle shall be repeated once again.
- 40.10 Final charge shall be given before wiring the cells to use.

41. PROCUREMENT OF STORES:

- 41.1 For the execution of the works, the contractor shall procure items of materials inclusive of miscellaneous and consumable items of Stores.
- 41.2 The specification for each material to be procured and used by the tenderer shall be as indicated against each item of material. All the materials and equipment's to be supplied and used for execution of work shall be to IRS specification wherever available, or to IS, if IRS is not available. In case of materials for which neither IRS nor IS specification is
- 41.3 available, detailed specifications with drawing have to be supplied by the contractor for approval of the K-RIDE/ Railways.
- 41.4 Materials not covered in RDSO's approved list of items and to be supplied by the contractor shall be of the best quality and from manufacturers of reputed establishments. The contractor shall produce Quality test, Warranty certificates from the manufacturers and the pamphlets in four copies to the K-RIDE. Materials covered under RDSO's approved list of items should be procured from those firms approved by RDSO only.
- 41.5 The contractor, will however have to procure all the tools and plants required for executing the labour portion of the work and before the actual commencement of the work, the contractor will satisfy the K-RIDE engineer that he has procured all the necessary tools and plant required of good quality. The contractor shall engage his own labour and supervisor for the execution for work covered in the contract.

42. USE OF TECHNICAL TERMS AND CONDITIONS, DRAWINGS AND SPECIFICATIONS:
Definition of technical terms and symbols used in circuits shall be as per Indian Standard Specifications and where such specifications are not available, they should be of British Standard Specification.

43. SPARES:

The Tenderer shall supply the essential spares as per the quantities indicated in respective Schedule of works.

44. DISCREPANCIES IN DRAWINGS AND OTHER DOCUMENTS:

The tenderer shall carry out at his expense any alteration of the work due to any discrepancies, errors or omissions in the drawings or other particulars submitted by him.

Any approval given by the K-RIDE/Railway for this purpose shall in no way absolve the contractor from any or all responsibilities for the correct function of the equipment. In this regard, the sole responsibility rests with the contractor in all respect. Any fittings or accessories which may not be specifically mentioned in the specification of tender documents or the letter of acceptance of the tender or the agreement executed thereof but which are usual or necessary as per normal Signal Engineering practice are to be provided by the contractor without extra charge so that the plant is complete in all respects.

45. ISSUE OF MATERIALS:

45.1 Extra care should be taken in the transportation of sophisticated Electrical and Electronic equipments like relays, power equipments, etc. to prevent from damage during transit. Further, these equipments should be stored in a covered place to protect from heat, dust, water, etc. These equipments should be installed and brought in use before the expiry of the shelf life

45.2 Material at Site statement shall be prepared and submitted as per the provisions contained in GCC by the K-Ride Engineer. The contractor must promptly submit the monthly return of the issued stores to K-Ride Engineer in the first week of every month without fail.

45.3 If at any time, any material which the contractor would normally have to arrange for himself for executing the works, is supplied by the K-RIDE/Railways, either at the contractor's request or suo-moto in order to prevent possible delay in the execution of the work due to contractor's inability to make adequate arrangements for the supply thereof or otherwise such materials will be made available to the contractor in the Railways Stores. All handling thereof will be the contractor's responsibility. Recovery of the cost of such supply materials will be made from the contractor's bills as per extant rules of the K-RIDE

46. RETURN OF SURPLUS/ RELEASED MATERIALS:

46.1 The contractor has to return any cut pieces of cables, wires, etc., that may be left out and surplus materials from the drums and other packing materials that might have been handed over to him. No extra payment will be made for this and the unit price quoted against the various items should include this work also. The surplus materials have to be handed over as per the instructions of the Engineer- in-Charge of the work

- 46.2 The contractor shall take proper written acknowledgement from the Engineers Representative For all the materials returned by him.
- 46.3 All tools that are required by the contractor for the purpose of transportation of the materials, digging, concreting and erection, wiring and painting works shall be brought by the contractor himself. This shall include spare parts, fuel and consumable and miscellaneous stores. The rates quoted by the contractor shall be deemed to be inclusive of all charges for such items and inclusive of labour required to ensure efficient and methodical execution of work.
- 47. RECEIPT OF MATERIALS FROM CONTRACTOR:**
- 47.1 As soon as the materials are accepted by the K-RIDE from the contractor, DMTR entries are to be made immediately. While taking materials from the contractor, delivery challan issued by the firm, who has sold the materials to the contractor/trader and inspection certificate shall be insisted upon.
- 47.2 Fabricated items which are to be supplied by the contractor are to be checked thoroughly with the drawings regarding quality of the materials, gauge dimensions, etc. as per the schedule. Wherever any material is received from field/contractor, the detailed nomenclature shall be entered in the DMTR. In case of equipment, the details of manufacturer's name, year of manufacture, RDSO Test Certificate No., Serial No., Contractor's name and Agreement No. and place of installation shall be mentioned both in the DMTR and the ledgers.
- 47.3 Materials are normally to be delivered at designated Stores by the contractor. If they are delivered at site due to logistics/exigencies, the supervisor/officer receiving such materials (after verification of due inspection) shall arrange for necessary entries in the Site Inspection Register and ensure the entry in designated Stores' DMTR within a week.
- 48. INSPECTION OF WORKS:**
- 48.1 The Engineer or his representative shall inspect and test the various portions of the work at all stages and shall have full power to reject all or any portion of the work that he may consider to be defective or inferior in quality of materials workmanship or design in comparison to what is called for in the specification. In the event of rejection of any work already executed and not in accordance with specification as in this tender and/or as determined by the Engineer or which the Contractor has been apprised, the contractor shall carry out alterations/ replacements to such works to the satisfaction of the Engineer for which no additional expenses will be borne by the K-RIDE.
- 48.2 The contractor shall submit detailed test procedure for each equipment, sub-system and system as a whole to the K-Ride. The K-Ride shall discuss with the contractor and modify the test procedure as may be required to ensure that the requirement of tender specifications are complied. The finalized test procedure shall, only, act as a broad guideline and K-RIDE shall be free to carry out any other tests that may be considered essential. The test procedure shall give details of all equipment, test and measuring instruments required to perform the tests which shall be provided by the contractor free of cost.
- 49. ATTENDING TO DEFECTS:**
- The contractor shall rectify defects that may arise in the work executed during Maintenance period after completion of work, such defects being due to bad workmanship on the part of the contractor or otherwise. Should any dispute arise so as to correctness of the defect pointed out, the Engineer's decision in this regard is final and binding.

50. INSPECTION OF MATERIALS:

- 50.1 Materials to be supplied by Contractor shall be of best quality and shall conform to the relevant specifications, Designs and Drawings. The materials shall be procured by the Contractor/s from manufacturers of repute or their authorized dealers as approved by the Engineer-in-Charge.
- 50.2 The contractor should procure signaling/telecom items which appear in the RDSO approved list of suppliers. The contractor shall take prior approval of the K-RIDE before placing orders on the firms.
- 50.3 The items which are included in the list of RDSO approved suppliers (Electrical Signaling items) shall be inspected by RDSO and Mechanical Signaling items shall be inspected by RITES except petty items which shall be inspected by representative of the Engineer-in-Charge. The RCC products, GI Pipes, FRP type TLD Boxes, Apparatus Case, HDPE Pipe, Polyolefin Cable channel and Earth Electrodes, shall be inspected by RITES. In case the value of Electrical signaling items is less than Rs. Five Lakh, the inspection shall be carried out by Consignee. In exceptional cases, the consignee inspection shall be carried out by an Official nominated for the purpose. Even in these cases, the materials shall be procured from RDSO approved sources.
- 50.4 The following critical items will continue to be inspected by RDSO irrespective of its value:
- (a) All Types of Signalling Relays
 - (b) Block Instruments
 - (c) Axle Counter Equipments
 - (d) All Power Supply Equipments
 - (e) Electric Key Transmitter
 - (f) Terminal Blocks (PBT type)
 - (g) Electric Point and Lock Detector
 - (h) Electronic Interlocking system.
 - (h) Data Loggers
 - (i) LED Signals
 - (j) PVC Wire Copper for signalling
 - (k) Maintenance Free Earth.
- 50.5 All materials that are not covered under specification, designs and drawings of RDSO, Railway Board, etc., will be procured by the Contractor from the manufacturers of repute/their authorized dealers, after the approval of the Contract Signing Authority
- 50.6 Materials to be supplied by the contractor shall be put up for inspection of Engineer or his representative for checking its quality/ suitability before they are finally used/ installed by the Contractor and necessary inspection certificate to be obtained. The Contractor shall therefore arrange to get the material inspected in advance, preferably in bulk and not in piece-meal. The Contractor shall give the K-Ride 10 (Ten) days" notice, when the materials are ready for inspection.
- 50.7 All materials to be supplied by contractor should be offered by him/them for RDSO"s/RITES inspection, well in time, so as not to delay the progress of work at any stage at any of the stations in any way on this account.
- 50.8 If required, the Contractor shall provide at point of production, apparatus and labour for making required tests under the supervision of the K-Ride. Tests may be made either at point of production, on samples submitted or at the destination.

51. FACILITIES FOR TEST & EXAMINATION:

The contractor shall provide, without any extra charges, all materials, equipments, tools and labour of every kind which the RDSO/RITES or their nominee may consider necessary for any tests and examinations which they or their nominee shall require to be made on the contractor's premises and shall pay all cost attendant there upon. The contractor shall also provide and deliver free of charge at such places as the RDSO/RITES or their nominee may nominate such materials as they or their nominee may require for the independent testing organization. The cost of any such tests will be defrayed by the K-RIDE unless it is stated in the specification that it is to be paid by the Contractor.

52. CERTIFICATE OF INSPECTION AND APPROVAL:

52.1 No stores will be considered ready for delivery until RDSO/RITES/K-RIDE/Railway inspecting officer nominated by them have certified in writing that the material has been inspected and approved by them for dispatch.

52.2 Facilities must be provided by the contractor to the K-RIDE or their nominee for inspection of the stores, equipments and structures at all stages of their assembly, manufacture and fabrication.

53. INSURANCE:

53.1 The contractor shall take out and keep in force a policy or policies of insurance against all liabilities of the Contractor or the K-RIDE at common law or under any statute in respect of accidents to persons who shall be employed by the Contractor in or about the site or the Contractor's Office for the purpose of carrying out the contract works on the site. The contractor shall take about and keep in force a policy or policies of Insurance against all recognized risks to their office accommodation and storage for which he is liable. Such insurance shall in all respects be subject to the approval of the K-RIDE.

53.2 The Contractor shall take out and keep in force a policy or policies or insurance for all materials handed over to him irrespective of whether used up in the portion of work already done or kept for use for the balance portion of the work until such works are handed over to the Railway.

53.3 For this purpose, the works are deemed to have been handed over when final acceptance certificate is issued by the Engineer after the completion of the entire acceptance test to be conducted on the works. The contractor shall not be liable for losses/damages to the materials either used up in the portion of work done or the materials kept for use at site, in consequence of mutiny or other similar causes over which the contractor has no control and which cannot be insured. Such losses or damages shall be the liability of the De.

53.4 The Contractor should, however, insure the stores brought to site, against risks in consequence of war and invasion, as required under the Emergency Risk (Good) Insurance Act in force.

53.5 The Contractor shall take out all insurance covers in connection with this contract with the General Insurance Corporation of India.

54. AVOIDING INFRINGEMENT OF INDIAN RAILWAY ACT:

54.1 The works must be carried out most carefully without any infringement of the Indian Railway Act or the General and subsidiary rules in force on the Railway, in such a way that they do not hinder Railway operation nor affect the proper functioning of or damage any Railway

equipment, structure or rolling stock except as agreed to by the Railway, provided that all damage and disfiguration caused by the contractor to any Railway or Public property must be made good by the contractor at his own expenses failing which cost of such repairs shall be recovered from the contractor.

54.2 No work on the points, track circuits, equipments involving working signaling gears, internal wiring, cable termination, etc., should be done unless and until contractor's technical supervisors are present at site.

55. CONTRACTOR'S DRAWINGS:

55.1 Any work done by the contractor prior to the approval of the contractor's drawings will be done at the risk of the contractor unless previously authorized in writing by the K-RIDE.

55.2 The tenderer shall be responsible for the correctness of the drawings furnished by him. The contractor shall carry out any alterations of the works due to any discrepancies, errors or omissions in the drawings or other particulars, submitted by him. Any approval given by the K-RIDE/Railways for this purpose shall in no way absolve the tenderer from full responsibility for the execution of the contract in all respects.

55.3 After the contract is awarded, the contractor shall furnish to the K-RIDE required, prints of contractor's drawings that form an essential part thereof. No change shall be made in any approved drawings without the written consent of the K-Ride/Railways.

55.4 After completion of the execution of the contracts, the contractor shall submit to the K-Ride/Railway all corrected tracing film/cloth tracings of drawings furnished by him and prescribed sets of copies of final drawings.

55.5 Notwithstanding the fact the K-Ride/Railway might have approved or the contractor's design, drawings and specifications the contractor is responsible for the correctness of the entire scheme as a whole and its satisfactory performance to the specifications as laid down by the Railway. The K-Ride/Railway's responsibility is only for the correctness of the signaling plans.

55.6 In the event of any breach of the aforesaid conditions, the contractor shall in addition to throwing himself open to action for contravention of terms of the agreement and or for original breach of trust, be liable to account to Government for all moneys, advances or profits resulting or which in the usual course would have resulted by reason of such breach.

PART-(II)

TECHNICAL REQUIREMENTS OF EARTHING ARRANGEMENT

1. Earthing arrangement for Electronic Interlocking and End goomties shall be as per RDSO Guidelines STS/E/TAN/3006 or latest and further guidelines issued by K-Ride board/ RDSO for achieving earth value less than One Ohm. At locations, where it may not be possible to form a perimetric ring earth around the EI room, Power supply room and station room, in such stations parallel earthing arrangement consisting of interconnected multiple earth electrode may be made at the free space near the station building such that following requirements are made
 - (a) Single point entry of Main earth bond with all other cables to the EI room shall be adhered.
 - (b) The earth connections to the Perimetric ring earthing for all the items shall be made using shortest possible path.
 - (c) All earth electrodes must be interconnected with buried conductor however visible and provided with RCC enclosure/ skirting.
2. The lightning protection system shall be installed in accordance with RDSO/SPN/197/2008 or latest and additional requirements of local authority. The system shall consist of air terminations, down conductors, joints & bends, testing joints, earth terminations & earth electrodes. Advanced lightning protection system shall include components as follows: Air terminations, mechanical supports, low impedance insulated down conductor, performance recording equipment, and a low impedance grounding earthing system.

2.1 Design of Lightning Protection System

2.1.1 Air Terminal

Advanced Controlled Streamer Emission based Lightning Protection System is suitable for protection of Buildings and Towers against Direct lightning Strike complete with Controlled Streamer Emission (CSE) lightning conductor air Terminal. The round shaped Air terminal should be based on the latest lightning research and technology, which has an enhanced area of protection. Placement of the Air terminals is determined using the „Collection Volume Design Method“. Unlike conventional design theories, this method provides an imperial and quantitative method based on design parameters such as the structure height, field intensification of structural projections.

The Controlled Steamer Emission Air Terminal shall be working on the principle of field intensification and responds dynamically to the appearance of a lightning downleader by creating free electrons and photo-ionization between a semispherical surface and an earthed control finial and chart have a shape of semi-spherical with outer diameter of 260mm and height from the base of 115mm. and approximate weight of terminal being 2.8 Kg, to significantly reduce the build up of sharp point corona discharge under static field thunderstorm conditions.

The supporting accessories and mast system are comprising of the insulated FRP pipe of min. 2m length, high grade Aluminium mast of min. 2 Mtr., the U Bolts so as to withstand maximum recorded wind velocities of 100 kmph and the Event Counter with triggering impulse of 1500 Amps. For 8/20 micro second without any external power supply and complete as required as per the specifications. The Air Terminal should be UL listed as per

the UL96. "Lighting Protection Components" (Standard for Safety). The round shape of the Air Terminal is designed to reduce the buildup of Corona space charge which inhibits the formation of upward streamers. Standard Franklin rods and ESE terminals which are pointed, create a lot of Corona which is a main reason for conventional lightning protection system failures. The geometry of the air terminal is a significant factor in its performance. The round Air Terminal launches a streamer before other competing structures of the structure can launch their streamers giving it a time advantage, which allows its streamer to become the preferred attachment point for the approaching down leader.

The protective zone provided by the air termination shall be such that it becomes the preferred strike point for all discharges exceeding a peak amplitude return strike current of XkA, according to the statistical level Y per IEC 61024. The design shall take account of upward leader competing projections on the structure.

Strike Current (X)	Level of protection (Y)	Exceedance Probability
2.9 kA	Protection Level-I Very High	99%
5.4 kA	Protection Level-II High	97%
10.1 kA	Protection Level-III Medium	91%
15.7 kA	Protection Level-IV Standard	84%

2.1.2 Down conductor

The Down conductor should be in form of multi layered cable consisting of plastic filler, multi stranded copper conductor with the cross sectional area of 55 Sq.mm. inner insulation, outer copper conductor, conductive sheath, all concentrically arranged with outer diameter of 36mm. characteristic impedance of 4.5 Ohms, inductance of 22nH/m and voltage withstand capability of 250kV, i.e. core to screen 250kV based on 1/50us wave shape as defined under ANSI C62.41, with factory done upper termination and the kit for lower termination and all fixings and accessories as per specifications. The multilayered cable is the Shielded conductor which reduces the risk of side flashing to the building/structure, thereby eliminating the possibility of damage of equipment and injury to people. The conventional GI or Copper strips can cause side flashing.

The down conductor shall have a capacitance equal to 1100 or greater than 1100 pF/m and the resistance should be equal to or less than 0.5m.ohm/m.

The main copper conductor of Down conductor cable shall be capable of direct connection to the base of the air termination by use of a compression coupling or CADWELD

2.1.3 Performance recording Equipment

Each Protection system shall be provided with Lightning Event Counter. The lightning event counter shall have a register that activates one count for every discharge where the peak current exceeds 1500A. The test wave shape shall be the 8/20us standard as defined by A SI C62.41. The lightning event counter shall be robust, easy to install & housed in a IP67 rated enclosure. The counter shall operate from the energy of the lightning discharge and not depend external or battery power to operate. The lightning event counter shall be installed to the manufacturer's instructions in a readily accessible manner so that readings can be taken at regular intervals. It shall be so positioned such that its operating temperature is within the range -10 deg. C to +50 deg. C.

PART-(III)

TECHNICAL REQUIREMENTS OF HIGH AVAILABILITY SINGLE SECTION DIGITAL AXLE COUNTER

1. The High Availability Single Section Digital Axle Counter (HASSDAC) must be confirming to RDSO Specification no. RDSO/SPN/177/2012 (Ver. 3) or latest and shall be provided with High Availability Dual track sensor.
2. Wiring Discipline should be as per RDSO TAN No. STS/E/TAN/6001, dtd. 04.10.2011.
3. 19" rack Mountable Multi service multiplexer chassis consisting of 4 E1 Interface uplink and 3 module slots, one slot populated with 2W/4W E & M supporting up to eight interfaces, balance two empty, unit should supports both AC/DC power supply (MRO TEK make MAPLE 4C PCM 1U or similar specifications) shall be provided for auto changeover of the transmission media.
4. Requirements as per Para 18 of RDSO specification no. RDSO/SPN/177/2012 (Ver. 3)
 - i. Configuration : 2 DP 1 Section
 - ii. Length of cable : 15 Meter
 - iii. Supply option :
 - a) High Availability SSDAC
 - b) Dual track sensor device

STATION- A

BLOCK SECTION

STATION- B

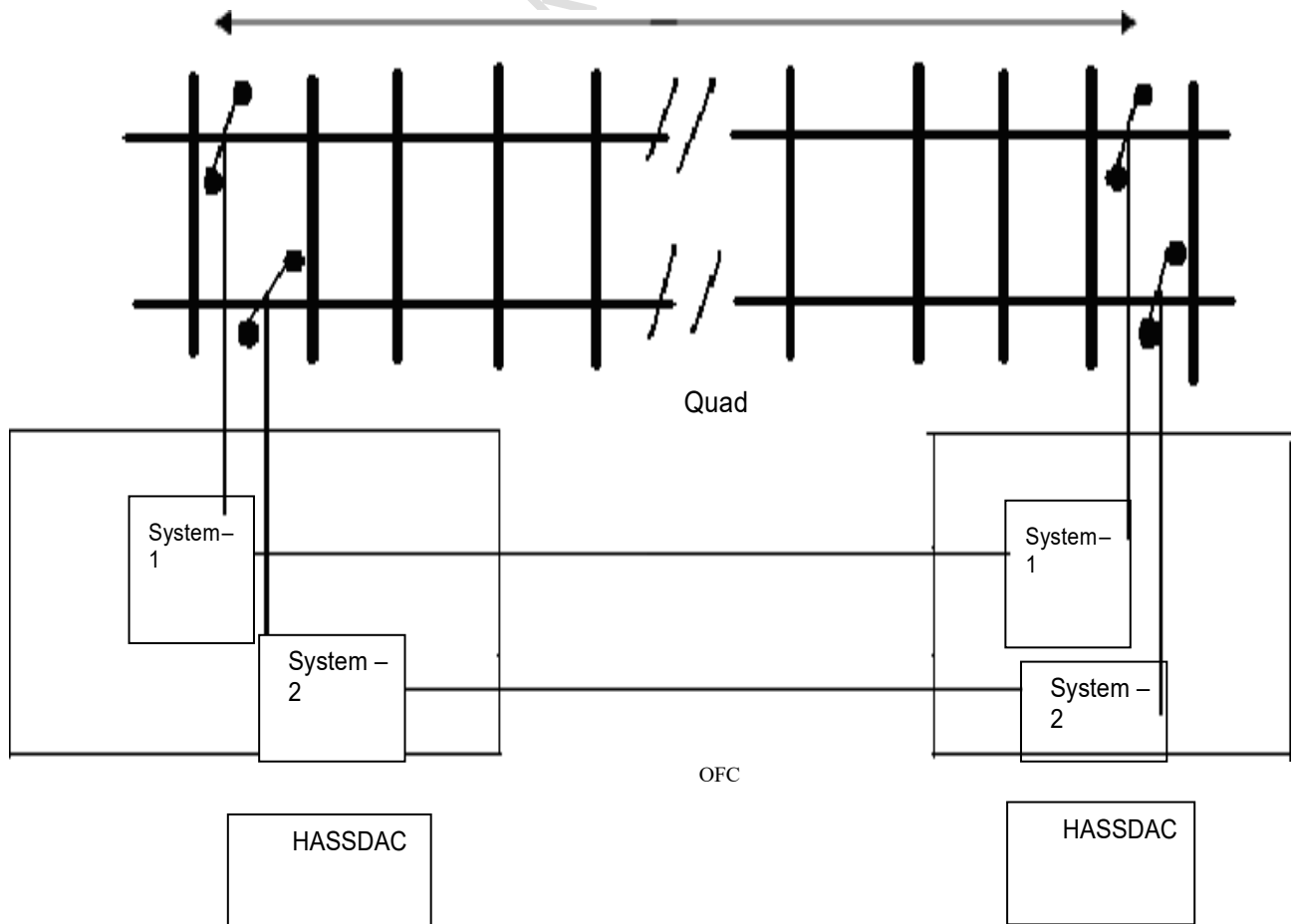

- a) Two sensors shall be put on two different rails with 1.25m longitudinal spacing along the track. This will ensure 2m diagonal distance between two sensors.
 - b) HASSDAC having system – 1 & system – 2 shall be preferably using diverse media (Quad/OFC).
 - c) When one of the SSDAC is clear whereas other is showing occupied for more than 10 seconds, the clear SSDAC will automatically reset the failed one.
 - d) All resetting will only be of preparatory reset type.
 - e) Use of dual track sensors on different all with high availability system is based on MTBF requirements.
5. Wiring and Installation and Commissioning details:
1. Fixing of MSDAC/HASSDAC system in the location box.
 2. Wiring of of MSDAC / HASSDAC system in the location box. (The different cables for signalling & Communication cable will be laid and terminated in the location box).
 3. Supply, fixing and wiring of suitable Lightning Dischargers, fuse terminals and fuses.
 4. Marking and drilling of holes in Rail, fitting of track device and laying of underground cable from the of MSDAC / HASSDAC system to track device using 40mm dia HDPE pipe. Trans and receive cables has to be taken in separate HDPE Pipe. This includes required trenching from location box to track device. All the materials including HDPE & Cable from system to track device to be supplied by the contractor.
 5. Fixing, wiring and installation of Reset box in the SM's room. This includes the supply & fixing of 25mm PVC casing & capping and drawl of required cable from reset box to Cable Termination Box. All the materials like cable, PVC casing & capping to be supplied by the contractor.
 6. Connecting of HASSDAC system at location box and reset box at SM's room to earth bus bar
 7. HASSDAC will be installed, wired, tested & commissioned by OEM's engineer as per guidelines issued by RDSO. The pre-commissioning check list issued by RDSO for SSDAC will be prepared by OEM's Engineer and signed jointly with Railway/ K-RIDE Engineer. Before commissioning of SSDAC, OEM will submit site installation certificate to Railways by mentioning that SSDAC has been installed, wired, tested and commissioned by OEM.
 8. 19" rack Mountable Multi service multiplexer chassis and interface equipments required for Mountable Multi service multiplexer chassis should be installed and configured as per requirements of Railway/ K-RIDE Engineer at site.

PART-(IV)

MULTI SECTION DIGITAL AXLE COUNTERS:

MSDAC is a multi-section digital axle counter system that is designed using the principles of fail-safety and has failsafe architecture. It is microcontroller based and has redundant power supply arrangement. Its modular nature allows you to plan your upgrade and extensions without any problem. It is extensible with 8 detection points in a module set. It provides an easy to use GUI for configuration.

It is used for detecting railway track occupancy primarily in a station. It is used for track circuiting a whole station. MSDAC is modular in design and can be used with more detection points per chassis. Each detection point has a track sensor that identifies a track section boundary. A track section can be defined with 2/3/4 detection points.

The system consists of the following components:

1. Axle Detectors
2. Electronics Field Units
3. Central Evaluator
4. SM's Reset Panel
5. Monitoring Unit

The Central Evaluator of MSDAC has been designed to be modular. The system can be configured for up to more field units in steps. Therefore, the system has the provision to scale up or scale down according to the requirement at station.

The Axle Detectors are installed at the limits of a track section along with their electronic field units on track side. The number of detection points is decided based on the track circuiting requirement of a station. The field units are connected with Central Evaluator by means of ½ Quad cable. The Central Evaluator is installed at the station and is powered by 24V DC local supply. The field units are also powered using 24V DC that is derived from the power source that powers the central evaluator. The Axle Detectors operates on high frequency (As applicable) electromagnetic wheel detection technology. When a train wheel passes over the Axle detectors, the change in electromagnetic field is sensed. This change triggers a complex algorithm that decides if a wheel has passed over the axle detector. The Axle detectors and the electronics associated with it is working on the principle of Phase Modulation.

The wheel-detection events are converted into pulses and these pulses are counted by the field units. These counts are stored as well here. The stored counts as well as the heal of the track sensor are monitored and are continuously transmitted by the field unit by means of telegram packets to Central Evaluator on the ½ Quad cable that also powers the field unit. The central Evaluator receives the count from each of the field unit it is connected to and it then takes the decision of the track section is occupied or not. MSDAC signals the occupancy of the track section by means of an electro-mechanical relay called VR relay. The contacts of VR is used in the signaling circuits of signalling system at the station.

MSDAC has a mechanism to reset a particular track section to recover from an error or a failure condition. This is done through the SM's reset panel. The section is to be physically verified by the SM to be unoccupied and then the reset command is to be given from the reset panel. This command is received by the central evaluator and it then send the command to the respective field units to zero their counts.

It is designed in accordance with the RDSO specification No. Specification No. RDSO/SPN /176/2013 (Version 3) or with latest amendments

Specification of Portable Data Analyser:

Supply of Data Analyzer similar to HP /IBM/Dell or better specifications of following configuration. Necessary software tools required for data analysis should be pre-installed in the system.

Microprocessor	2.50GHz 3rd generation Intel Core i5-3210M Processor or latest processor with Turbo Boost Technology up to 3.10GHz or better
Memory	Minimum 8GB DDR3 SDRAM (2 DIMM)
Memory Max	Maximum supported - 16GB
Memory Slots	2 user accessible
Video Graphics	Intel HD graphics 4000 with up to 1696MB total graphics memory
Display	15.6-inch diagonal HD Bright View LED-backlit display (1366x768)
Hard Drive	1TB 5400RPM hard drive with HP Protect Smart Hard Drive or similar Protection
Multimedia Drive	Super Multi DVD burner
Network Card	10/100/1000 Gigabit Ethernet LAN (RJ-45 connector)
Wireless Connectivity	802.11b/g/n WLAN
Keyboard	Full-size island-style keyboard
Pointing Device	Touchpad supporting multi-touch gestures with on/off button
External Ports	Multi-Format Digital Media Card Reader for Secure Digital cards & Multimedia cards 3 SuperSpeed USB 3.0 1 Universal Serial Bus (USB) 2.0 1 HDMI 1 VGA (15-pin) 1 RJ-45 (LAN) 1 Headphone-out/Microphone-in combo jack
Dimensions	14.94 in (W) x 9.87 in (D) x 0.87 in (min H)/ 1.04 in (max H)
Power	65W AC adapter 6-cell 62WHr 2.8 Ah lithium-ion battery
ID Mech Description	HP TrueVision HD Webcam with integrated dual array digital microphone
Operating system	Genuine Windows 10

Multi Section Digital Axle Counter (MSDAC) System complete shall confirm to RDSO Specification No. RDSO/SPN/176/2013 (Version 3) or with latest amendments shall be supplied.

Tenderer shall design the scheme for

- a) Provision of required number of Evaluators, Track-Side junction boxes, Detection points and Track Clearance Relays etc.
- b) During the design, tenderer shall ensure that MSDAC Evaluators to be kept at Relay room /IB Huts in the section.
- c) The MSDAC system provided in the IB-section will be interconnected with 6Quad and OFC cables. In case of failure of 6Quad/OFC cable the MSDAC system shall automatically changeover the other cable seamlessly; this system shall be capable of transferring the data, status of relays from IB station to adjacent stations safely as per site requirements and the indication of working cable to be shown as status at JE/SSE Room
- d) Tender design shall include marking of Track Section over the IB Section and ensure that the resetting of Track Section will be done Automatically and Manually as the case may be.
- e) Schedule-H include - Supply of MSDAC system comprising of Axle Detectors, Track side electronics / DAC field units, Central Evaluator, reset unit, relay unit, LV/Co-operation box, etc with all other accessories fully wired and fully equipped. - Necessary 24V supplies including DC-DC converters will be arranged through IPS.
- f) Configuration of MSDAC at site by OEM or authorized OEM representative.
- g) Lightening and Surge Protection for MSDAC as suggested by OEM.
- h) Supply of Technical Documents/Manuals, Trouble Shooting Guidelines etc.,
- i) Provision of Track Detection using MSDAC in BYPL-HSRA section in Bangalore division
- j) Provision of MSDAC Track Section status to the either end of stations for monitoring, testing and commissioning of the entire installation should be done by authorized OEM representative.

PART- (V)
TECHNICAL REQUIREMENTS OF DESIGN AND
DRAWINGS

General:

- 1.0 Design of signalling circuits should meet the requirements of Signal Engineering Manual, Recommendations of Working Group on Signalling Practices and Interlocking Principles (SP & IP) accepted and circulated vide Ministry of Railway letter no. 2010/Sig/WG/Interlocking Principle, dated 22.05.2012, typical circuits issued by RDSO and Table of Control (TOC) approved and issued by K-RIDE through Railway. The K-RIDE/ railways shall issue hard and soft copies of the Signal Interlocking Plan (SIP) and TOC to the contractor.
- 1.1 Circuits shall be designed to RE standards unless specified otherwise. All interface circuits shall be designed with indirect feeding of signals for non-RE area also.
- 1.2 System shall be designed for use with Dual Video Display Unit (VDU).

2.0 Version Control:

- 2.1 Strict Version control shall be exercised. The Check Sum/ CRC details shall be furnished with the initial application logic and changed Check Sum/ CRC along with details of changes in Application Logics subsequently. No change in the Application Logic shall be made without the approval of K-RIDE/Railways.
- 2.2 After making any change in application logic, a comparison statement shall be submitted duly indicating the checksum prior and after the change.
- 2.3 In case of no change in Application Logic during Factory Acceptance Test (FAT) and System Acceptance Test (SAT), the checksum of the initial submission and that of the service version shall be the same.

3.0 Design:

- 3.1 The interface circuits must be designed as per the final phase of the Signalling plan so that alterations in the existing interface wiring of initial phases is limited to removal of wires and minimum re-use of bits so as to minimize the interface wiring alterations during Non-interlocked working period in subsequent phases. Additional functions/ alterations shall be catered in new terminations to the extent possible.
- 3.2 Terminations shall be grouped function wise.
- 3.3 In ASR logics, read back contact of HR/ DR/ UGR shall not be proved. It shall be ensured that all ASRs are dropped before booting the system.
- 3.4 Crank handle logics shall be designed with NLR and RLR up contacts instead of back contact of HR and UCR.
- 3.5 CHRZR shall be slow to release for 30 sec for extracting the Crank Handles comfortably.
- 3.6 In LR Logics, parallel movements with conditional points shall not be proved. However, these shall be ensured in UCR and HR logics.
- 3.7 In Point operation circuit, XR shall be initially dropped before picking up WJR.

- 3.8 ZWLKRs shall not be split and there shall be only one ZWLKR for a point with different conditional movements.
- 3.9 In UCR logics, conflicting ASR/ TRSR/ TLSR shall be proved but for Calling ON signals, only UCR back contact of the main signal above it shall be proved.
- 3.10 In yards with sectional route release, K-RIDE shall indicate the track circuits to be used in the ASR logics in the Table of Control (TOC) and all other back lock track circuits shall have sectional route release.
- 3.11 In HR logics, drop contact of all the sectional route release bits (TRSR/TLSR) of the same direction in the route and up contacts of the conflicting direction shall be proved. For overlap, the conflicting ZR, ZR-C, SHZR up contacts shall be proved.
- 3.12 In ELUYR/ERUYR logics, TSR & TSSLR down contact shall be proved in parallel to track circuits down contacts.

4.0 Documentation:

- 4.1 As per SEM, part-I, Para No.8.3.4, the circuit diagrams shall be in A3 size sheet (297mm x 420mm) with 10MM border and on left hand side an extra margin of 30mm should be allowed for bidding.
- 4.2 Plotting shall be done with minimum border setting in AutoCAD on the A3 size sheet.
- 4.3 Relay/ Contact font size should be 2.5 mm and style Times New Roman – Auto CAD.
- 4.4 Negative shall be tracing film for approval of As Made and after approval and signature thereon, RTF shall be submitted. As made negative print must not be fade and spread when subjected to any kind of liquid/ water drops.
- 4.5 Minimum space in the design elements in Interface or Relay circuits shall be maintained as follows:
 - (i) Arm to contact: 10 mm
 - (ii) Arm to Arm: 22 mm
 - (iii) Line to Line: 25 mm

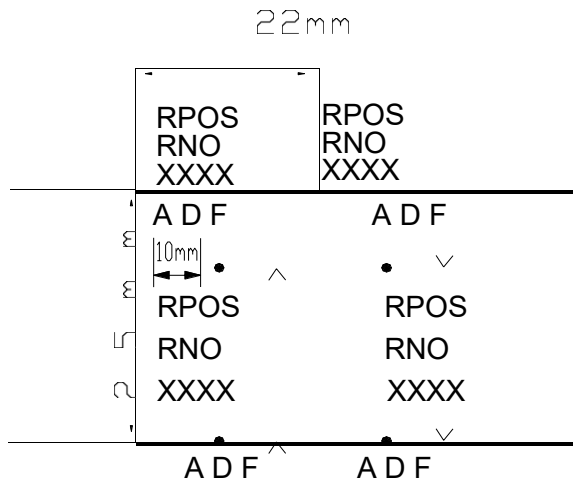

4.6 Minimum space in the design elements in Interface or Relay circuits shall be maintained as follows:

- (i) Arm to contact: 10 mm
- (ii) Arm to Arm: 22 mm
- (iii) Line to Line: 25 mm

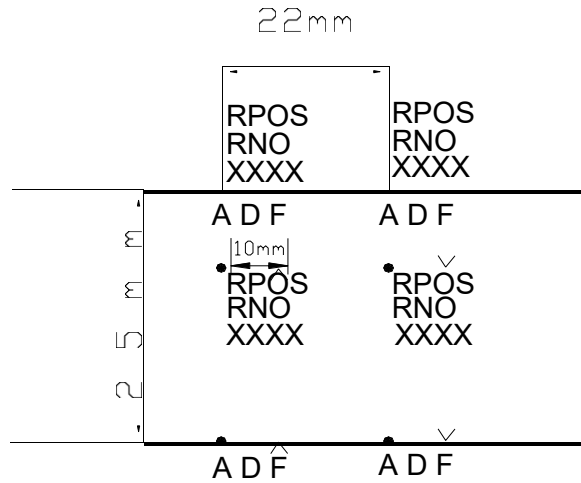

4.7 Minimum space in the design elements in Application Logic circuits shall be maintained as follows:

- (i) Arm to Contact: 10 mm
- (ii) Arm to Arm: 22 mm
- (iii) Line to Line: 15 mm

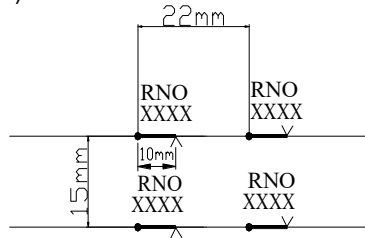

4.8 Height of Title signature column) should be 30mm from inner borderline.

4.9 Minimum space in the design elements in Application Logic circuits shall be maintained as follows:

- (i) Arm to Contact: 10 mm
- (ii) Arm to Arm: 22 mm
- (iii) Line to Line: 15 mm

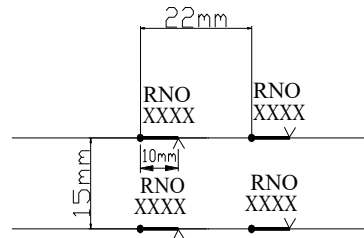

4.10 Height of Title signature column) should be 30mm from inner borderline.

4.11 Sheet Nos. should be serially marked in X of Y format without omitting any numbers in between sheets.

4.12 Each booklet of Interface Circuit and Application logic shall be limited to 200 sheets for the convenience of handling. Index shall clearly indicate the specific description of circuit on each sheet.

4.13 Outdoor location termination and wiring details shall be incorporated in the As Made Interface circuit diagrams.

4.14 Circuits shall be grouped in the sequence of signal initiation to route release, panel indication, Block and Miscellaneous circuits as follows:

- KNOB/ BUTTON LOGIC
- NLR/ RLR
- LR/ UR
- NR/ RR
- ZNR/ ZRR
- ASR
- LOHR/ ROHR
- ROUTE CANCELLATION/ EMERGENCY CANCELLATION
- TRSR/ TLSR/ TLZR (STATION WITH SECTIONAL ROUTE RELEASE)
- POINT OPERATION
- PCR
- NWKSR/ RWKSR
- ZWLKR
- UCR
- CRANK HANDLE
- TSR

- HZR
- HR/DR/UGR
- INDICATION
- BLOCK/UFSBI, BPAC
- GFXR/ UNCR BUZZER/ POWER FAILURE/ TJ FAILURE/ DC-DC FAILURE LOGICS
- FCOR
- REDIRECTIONAL
- DATA LOGGER
- MISCELLANEOUS

4.15 After each group of circuits, Spare blank sheets shall be provided duly indicating in the index sheet while submitting for initial approval. These spare blank sheets shall be utilised for incorporation of any additional logic during subsequent stages of design, checking and testing without disturbing the sheet numbering.

4.16 Approved design sheet template shall be adopted for design of the Border, Title, Version and Signature block. Contractor must ensure the verification and collection of the same from the office of the Chief Signal & Telecommunication Engineer (Construction), South Western Railway before start of the design.

K-RIDE

PART-(VI)

TECHNICAL REQUIREMENTS OF AS MADE DIAGRAMS

1. The following as made Design and documents shall be prepared by the contractor after completion of the work and submit the same for approval through K-RIDE by Railways. After receiving the approval, Soft copy in two sets and Hard copy One set on tracing film and 6 Sets of the bounded Blue Prints of the following design and documents shall be handed over to the K-Ride / Railway.
 - (a) Equipment Layout diagram
 - (b) Application Logic and associated Circuit diagrams
 - (c) Interface circuits
 - (d) Wiring diagram of All EI equipments including Object Controllers
 - (e) Panel Termination particulars
 - (f) Relay Contact particulars
 - (g) Terminal Analysis diagram
 - (h) Fuse Particulars
 - (i) Inspectors Completion Certificate
 - (j) Relay Index and disposition particulars
 - (k) Power distribution diagram etc

2. The sizes of different signaling documents are standardized as follows. However, contractor shall take the confirmation about the sizes and media etc before undertaking preparation of As Made drawings and designs.
 - (a) Circuit diagram: A3 Size.
 - (b) Panel termination particulars, FTOT particulars, location particulars: A3 Size.
 - (c) Font name: Times New Roman – Auto CAD.
 - (d) Font size: 10- 2.5 mm

- (e). The above drawings to be made as per SEM/ CSTE Circular (copy may be collected from K-RIDE office).
- (f). Two draft copies of above drawings to be submitted for approval. One copy will be returned either duly approved for making a fair copy or for resubmission for approval after incorporating the changes as required by Railways.
- (g). After completion of each phase work, the Application logic and Interface circuits has to be updated as per bell test copy / SAT copy and submit 2 sets of corrected Application logic and Interface circuits in plain paper.
- (h). After preliminary approval, required 2 number of prints are to be submitted for Administrative approval. After the Administrative approval negatives of the above drawings have to be made in tracing films for signature in token of approval. After signature on the tracings, 6 sets of these drawings in ammonia/ blue prints kept in standard plastic covers back to back and bounded neatly shall be handed over to the office of GM/K-Ride.
- (i). One set of the above drawings shall be submitted in Reproduction Tracing Film with 2 sets of soft copy in CD"s/Pen Drive.

PART- (VII) Single line Tokenless Block instrument Handle type

Single line tokenless block instrument handle type shall ne supplied, installed as per RDSO specification S98-2001

PART- (VIII) TECHNICAL REQUIREMENTS OF ELECTRONIC INTERLOCKING

1. Electronic Interlocking (EI) system including sub systems to be offered should be as per RDSO Specification No. RDSO/SPN/203/2011 version 1.0 or latest for all the stations mentioned in the Scope of Work of SCC with Hot standby feature and have RDSO approval on the date of closing of tender.
2. Approved Signal Interlocking Plan of the proposed stations shall be issued as per the Milestone Activities and TDC specified in SCC and during the Kick off/ review meetings. However, Draft/ Tentative plans of the yards may be seen in the office of GM/S&T/K-RIDE on any working day.
3. Tenderer shall submit the Clause-by-Clause compliance to the RDSO specification RDSO/SPN/203/2011 Ver 1.0 including any deviation if any, to the specification along with the tender document
4. The tenderer shall submit the OEM support for 15 years from the date of commissioning of the system along with the tender document
5. Before Commissioning of Electronic Interlocking, Technical System Application approval as specified in RDSO TAN No: STS/E/TAN/3012 Ver. 2 or latest shall be obtained from the Competent Authority RDSO/PCSTE by the Railways. Contractor shall ensure the preparation and submission of the required documents at least two months in advance of the first phase commissioning schedule.
6. The tenderer shall submit the offer with the breakup of cost of the individual items (i.e., EI Cards, Design of EI, EI Racks, Relay Racks, Operator VDU, Maintenance VDU, Embedded PC, OFC/Media Converters, wiring, communication equipment, testing, commissioning etc) as required for commissioning of EI as per enclosed sketch. Any increase in quantity of items quoted or any requirement of additional items other than that shown in the breakup will be supplied by the contractor FREE OF COST.
NOTE : Tenderer has to quote the rates accordingly, as per the enclosed tentative SIP of Huskur station. The calculation for 15% spare IO/Ports will be based on only sketch enclosed along with the tender document.
7. Compatibility: The EI system to be provided shall be compatible with the existing Outdoor/any other equipment in use such as MSDAC/HASSDAC, SSBPAC UFSBI etc. Any interface required to be connected to the existing equipment to make the system functional shall be procured and installed by the tenderer. No

changes in the existing system will be undertaken by railways for the purpose of commissioning of EI system.

8. The interface equipment /device to the field signalling gears and operators VDUs should be complete and compatible with the signalling equipment existing at site in the stations. Any equipment/work required to make the interface equipment match with outdoor signalling equipment shall be done by the tenderer without any extra cost. Railway will not undertake any change in outdoor signalling equipment nor shall bear any extra cost on account of changes/addition required for ensuring compatibility of interface devices with outdoor signalling equipment.
9. Station Master is to be provided with two sets of VDUs/display systems with changeover facility. Where SM room and equipment room are situated in two different building, augmented surge protection/Optical Interface shall be provided by EI manufacturer.
10. CIU to be placed in the Central Relay room and OCs will be placed in S&T huts located at different locations in the yard. For communication between CIU and OCs, OFC arrangement with ring shall be provided. (OFC will be provided by Railways and all necessary connectors and interface equipment shall be provided by tenderer as per the schedule of works).
11. EI system shall comply with Instructions issued by RDSO till the date of tender opening in terms of Technical Advisory Notes and improvements.
12. The system should have capability to interface with Block working. It should also be capable of interfacing with IBS, ABS including interfacing with outlying yards and sidings
13. It shall be possible to achieve the block working through Electronic Interlocking with the same make EI system available at adjacent stations, being provided as part of this contract.
14. The Electronic Interlocking system shall be capable of future interfacing with ATP & CTC systems, TPWS, ETCS, Radio Block Centre/LTE & Other Advanced systems.
15. Various communication modules required for communication between EI, operator VDUs, maintenance terminal, object controller and Data logger are to be supplied and installed by the Tenderer as per schedule of works. All communication modules shall be of industrial grade.
16. It shall be possible to connect EI with Central Diagnostic Unit kept at Head Quarter or any other suitable place, used to diagnose faults/events related to hardware and software of EI. EI system shall have facility for automatic data transfer to a central diagnostic unit. Further all the EI systems provided as part of this contract shall be networked to central diagnostic unit.

17. Protocol converters required for connecting the EI system to Data loggers shall be provided by the contractor as per Schedule of works. Data loggers with required number of digital and analog inputs shall be supplied by the tenderer as per schedule of works. Net-working of Data logger to the control room will be carried out by the Railways. The time clock of EI system should be updated/ synchronized with data logger and it shall be possible to log the events in chronological order in case of use of either single/multiple EI with Data logger through CMU (central monitoring unit) if provided in network otherwise through protocol converter. External data logger shall be connected in such a way both for logging of analog/digital inputs of external functions and for EI modules inherent diagnostics. It shall be possible to connect EI with central monitoring unit kept at HQ control unit.
18. The terminals through which common positive or negative supply is provided to EI, must be duplicated, this shall also require duplicated power supply cables from power supply source to EI.
19. Information regarding Compliance of RDSO Specification is to be furnished by tenderer
20. The system shall have provision for accommodating additional 25% of Logical Bit spares/Timer spares in each CIU/Card File Level for facilitating minor alterations without hardware additions in future
21. The system shall have provision for accommodating additional 15% of I/O in the form of unused I/O cards slots or the unused bits in installed cards.
22. Details of power supply arrangements proposed for EI along with provisional load calculations shall be submitted by tenderer along with maximum current requirement after receipt of LOA.
23. The DC- DC Converters used for EI shall be provided in N+1 configuration with a safety factor of 1.5. Segregation between the DC-DC Converters for system A & B shall be made such that if any DC-DC converter fails only one system will be affected. The DC-DC converters shall be of make as recommended in RDSO Specification/Technical Advisory notes. All the DCDC converters used to provide the different supply to the EI Shall be provided for main and standby EI system separately. DC-DC converters shall be capable for working in non-air conditional environment and ambient temperature range between -10 °C to 70 °C and relative humidity upto 95% at 40 °C.
24. The power cables and the terminals supplying power to EI system shall be duplicated with minimum 16 Sq. mm Copper cables so as to provide redundancy
25. Availability of pure DC supply (harmonics and ripples free) for working of different modules/cards shall be the responsibility of the contractor.
26. The system shall work satisfactorily with input voltage variation from 150 V to 275 V AC and frequency variation from 48 Hz to 52 Hz
27. The short circuit & over voltage protection of self-restoring type shall be provided.
28. The required protection shall be provided to protect from any malfunctioning due to false/ spurious feed.

29. Suitable surge protection (Preferably Indicative Type) and proper earthing arrangement shall be provided to protect against transient voltages, lightning & spikes etc.
30. Power supply arrangement for individual processor should be such that, in case of fault in power supply of one processor, all processors should not cease to function simultaneously. It should be possible to switch off and take out faulty processor for repairing/replacement without affecting working of the balance system.
31. The signals are 110 V AC Lit and LED type as per specification RDSO/SPN/153/2002 with latest amendment or latest. Aspect checking relays are 'Q' Series LED ECRs.
32. Point Machines are universal type 110 V DC operated.
33. Track circuit relays are of "Q" Series QTA2 and QBAT
34. Axle Counters are High availability SSDAC or SSDAC or MSDAC Type or Universal axle counter type.
35. All equipment installed by tenderer should suit to 25 KV, 50 Hz, AC electrified (RE) territory.
36. The term track circuit may be read as track circuit /axle counter, wherever it appears in the technical specifications.
37. The input and outputs of the system may be derived as per South Western Railways' practice
38. If a relay of any style that is not used in Railways is required to be used, then prior approval of K-RIDE shall be obtained by the Contractor for its usage and the cost shall be borne by the contractor.
39. The interface required to drive the field gears will be relay interface or direct interface.
40. The whole interlocking of a yard shall be controlled by central operation but it shall be possible to place one VDU/Screen at end cabins, if required, to show yard status but the control shall be from the central location only. VDU PC shall have provision for connecting multiple screens/VDUs.
41. **Operator VDU:**
 - The software of VDU shall be certified by independent safety assessor.
 - The operator's VDUs shall be interfaced with EI. Dual VDUs shall be provided for operation of signals, points, LC gates and any other functions as recommended by engineer-in-charge.
 - If it is not possible to accommodate station layout in one screen legibly, the same shall be displayed in multiple screens as per schedule of works. All such screens shall be controlled from single computer. In case of multiple screens, it shall be possible to select a route even if entry button is in one screen and exit button is in another screen. Necessary fixing arrangements for VDUs shall be done by the tenderer.
 - Shall have Ethernet/OFC communication with the CIU, with suitable isolators.
 - Shall have required level of security features & access control for the operator/maintainer
 - Shall have key board and mouse operation.
 - Shall synchronize with the counters and clocks all the time and particularly when resuming from a failure.

- Shall support all buzzers/alarms/counters provided within or outside the system
- It shall be possible to analyse the operation and run the play back of the yard for the events of last 30 days or 1000000 events whichever is more.
- Embedded industrial grade fan less PC shall be provided and suitable compact flash disc memory space shall be catered for the backup requirements.
- Shall have required no of serial ports and Ethernet ports. The serial ports shall have inbuilt isolation or external isolation shall be provided.
- A flashing indication shall be provided on the VDUs to indicate healthy condition of the main system, communication channel. Three markers in red, blue & green colours respectively shall also be displayed prominently at conspicuous location on the VDU terminal to indicate that the colour monitor is healthy and all the three colours (red, blue & green) are present in right proportion.
- It shall be possible to display the status of the yard by distinguishing with two different colours (i.e., system active and system inactive).
- It shall be possible to display the complete yard layout including the block section on the set of monitor. The extent of functions of block section to be displayed in VDUs shall be as per the requirement of engineer-in-charge. It shall also have facility for displaying a portion of the yard or section in an enlarged mode or with scrolling arrangement, if required.
- Availability of communication channel shall be indicated by a constantly flashing indication. Whenever the communication channel goes faulty, a suitable error message shall be displayed on the terminal.
- Blocking of functions (points, signals, track circuits etc.) Shall be possible through VDUs. The blocking operations shall be achieved in fail-safe manner.
- If VDUs and CIU are in separate building/rooms, then they shall be interfaced using FOM (fiber optic modem) to protect against lightning and surges.
- Operation of signal gears shall not be possible simultaneously through both VDUs. Switching over of VDUs in hot standby with seamless changeover is required as per Railway requirements.
- Operator's VDUs shall be provided with hard SM Key to prevent unauthorized operation in addition to password protection.
- All the counters required as per SEM/G&SR or as per standard railway practice (such as route cancellation counter, calling on signal initiation counter etc) shall be part of the VDU. It shall be possible to view all these counters through VDUs and a record of these shall be available. Non resettable external counters with necessary wiring and fixing arrangements as per instructions of engineer shall be provided in the SM Room, if required in addition. The system shall have log of all the counters like emergency route cancellation, calling on signal, overlap release operation etc. And that will be logged in maintenance terminal. It shall be possible to read all counters as and when required. The VDU system as well as central interlocking unit shall have back up information on log of all counters provided on VDU like emergency route cancellation, calling on signal, overlap release operations etc.

- An Industrial grade embedded fan less PC of rugged and reliable type like MOXA series V2406, Kontron MPCX28R, MEN BC50M or similar with following minimum specifications or better or latest:

CPU	Intel Atom N270 1.6 GHZ Processor or better
OS (Pre Installed)	Windows Embedded Standard 2009/better version OS
System Memory	DDR2 SODIMM socket, supporting DDR2 533 up to 2 GB (max), built- in 1GB minimum
Storage	
Built – in	40 GB on board Industrial DOM minimum
Other Peripherals	
KB/MS	1 PS/2 interface supporting standard PS/2 Keyboard and mouse through Y-cable or USB mouse
Audio	Line-in, Line-out Interface
Display Monitor	55” Color Monitor Full HD
Ethernet Interface	
LAN	2 auto sensing 10/100 Mbps ports with M12 connectors
Serial Interface	
Serial standards	4RS-232/422/485 serial ports, Software selectable (DB 9 male)
Environmental Limits	
Operating Temperature	Wide temperature model that operate reliably in a -10 to 70°C operating temperature range

Ambient Relative Humidity	5 to 95 percent (non-condensing)
Anti vibration and Anti shock	Compliant with EN 50121-4 and essential sections of EN 50155
Power Requirement	
Input voltage	Compliant with EN 50155 on 24Vdc
Standard and Certifications	
Rail Traffic	EN 50155 (Railway Applications – Electronic Equipment on Rolling Stock)
Warranty Period	One year from date of commissioning
Fan less	Yes

- Requirement of Maintenance Terminal (MT)
 1. MT shall be used to diagnose problems/events related to hardware and software of EI. MT shall have facility for automatic serial data transfer to a central monitoring unit. The common protocol for this communication shall be as per data logger specification no. IRS: S-99 latest version for interface only.
 2. Shall consist of an Industrial grade embedded fan less PC from a reputed manufacturer
 3. Display of the current status of points, signals, controls etc. of the yard.
 4. Storage of minimum one-month data or 1000000 events whichever is more
 5. Display of recorded events and Data transfer to floppy, CD, flash memory or any other storage media.
 6. Transfer of recorded events to external data logger.
 7. Generation of exception reports shall be possible on MT for analysis purpose and past events simulation on yard layout etc.
 8. The soft copy of signalling circuits/manuals provide at the station shall also be loaded on MT for ready reckoner of ESM in simple/local language.
 9. MT shall be preferably connected to EI through OFC. If copper cable is used for connectivity the MT port shall be isolated from the port of EI. At both ends RS232 isolator/industrial grade opto-isolator shall be used.
 10. Control operation of yard functions shall not be possible from the maintenance terminal.
 11. Result of the failure of any card/module in the system should be clearly indicated. The supplier should also indicate process of replacing such defective cards / modules. Facility of display of faulty card/module for easy fault diagnostic shall be provided on the system.
 12. MT shall be user friendly and the displays on MT shall be self-guiding type for identifications of faults as well as for maintenance of system.
 13. In case of any module/ card becoming faulty, this fact should be displayed on MT with diagnostic facility to identify faulty module/ card.
 14. The displays on MT shall be self-guiding type for identifications of faults as well as for maintenance of system.
 15. An Industrial grade embedded fan less PC of rugged and reliable type like MOXA series V2406, Kontron MPCX28R, MEN BC50M or similar with following minimum specifications or better or latest:

CPU	Intel Atom N270 1.6 GHZ Processor or better
OS (Pre Installed)	Windows Embedded Standard 2009/better version OS
System Memory	DDR2 SODIMM socket, supporting DDR2 533 up to 2 GB (max), built- in 1GB minimum
Storage	
Built – in	40 GB on board Industrial DOM minimum
Other Peripherals	
KB/MS	1 PS/2 interface supporting standard PS/2 Keyboard and mouse through Y-cable or USB mouse

Audio	Line-in, Line-out Interface
Display Monitor	85" Color Monitor Full HD
Ethernet Interface	
LAN	2 auto sensing 10/100 Mbps ports with M12 connectors
Serial Interface	
Serial standards	4RS-232/422/485 serial ports, Software selectable (DB 9 male)
Environmental Limits	
Operating Temperature	Wide temperature model that operate reliably in a -10 to 70°C operating temperature range
Ambient Relative Humidity	5% to 95% (non-condensing)
Anti vibration and Anti shock	Compliant with EN 50121-4 and essential sections of EN 50155
Power Requirement	
Input voltage	Compliant with EN 50155 on 24Vdc
Standard and Certifications	
Rail Traffic	EN 50155 (Railway Applications – Electronic Equipment on Rolling Stock)
Warranty Period	One year from date of commissioning
Fan less	Yes

42. Long Term availability of Spares and System Support

The Contractor shall submit the OEM's assurance of continuous support for 15 years from the date of commissioning of the system for maintenance, modifications, and repairs of the system. The manufactures shall guarantee that spare parts for the system shall be available for life cycle period i.e. 15 Years. The tenderer shall give an under taking to supply on payment all

maintenance spares and tools required for the equipment during that period. In case of any plan to discontinue any equipment or components from the manufacturing process, at least one-year notice shall be given to the Railway before they are discontinued or phased out to enable Railways to order sufficient quantity of spares prior to stoppage of manufacture. This condition is to be observed for 14 years after expiry of warranty period of one year so that the Railways can procure for the components/modules from the supplier. The Tenderer shall undertake an agreement to enter into an AMC/ARC with Railways, if the Railway desires, beyond the period under which, supply of spare, repairs to defective cards and call charges for each visit as may become necessary shall be specified.

43. Design Requirements:

1. The whole interlocking of a yard shall be controlled by central operation.
2. The system shall be capable for working in non-air-conditioned environment and ambient temperature range between -10o c to 70o c and relative humidity upto 95% at 40o c.
3. EI shall have user-friendly graphic based design tool to generate station specific application software to carry out future yard modifications. It shall be possible for Railway to carryout minor yard modifications without the help of firm and the training shall be imparted to Railway maintenance staff for the same as per agreement with the Railway.
4. The medium of communication between OC and CIU will be OFC provided on a ring basis. In case of communication failure between CIU & OC, all the outputs shall be brought to safe state whenever two consecutive event communications are not received in stipulated time period.
5. SM Key contact shall be taken as Vital input to Electronic Interlocking with Interface Relay. To avoid possibility of single cause failure, the SM key having atleast double independent contacts shall be used. These two contacts shall be taken to EI in different input cards (and if possible in different OC). And in application logic, these final SM key bit shall be programmed to pick-up if any of these two inputs are available as per RDSO Lr No STS/L/SSI/General/Vol-I/198 Dt 17.05.2019
6. The system shall have facility of monitoring of internal variables as well as status of I/O. Through the maintenance terminal and data logger network of the Railway.
7. In case any peripheral equipment (such as VDU, MT, Data Logger etc.) Needs to be connected to the EI through serial ports and then EI system shall be page 124 of 164 isolated from the peripheral systems, suitable isolators shall be used for connecting the peripheral devices.
8. The response time of the system for the longest/complex route of a particular station shall be less than 5 seconds if Points are in favourable condition in that route. The response time indicated is the time from which command is given for operation of signal to receipt of signal aspect on VDUs.
9. The response time of the system for the longest/complex route of a station shall not be more than prescribed time limit set by Railways/RDSO if the points are in favourable condition in that route. Cycle time and response time to read and process the input shall be fast enough to ensure safety and avoid any apparent delay. Cycle time and response time of the system shall be clearly indicated.

10. System must work in hot standby with seamless changeover. Hardware and software architecture shall be provided with facility of automatic changeover. Train operation shall not be affected during changeover of the system. It should also be ensured that the fault, which affected the main processor/system, does not affect the hot standby processor/system.
11. The object controllers may be required to be provided at different locations in the yard as per outdoor requirement. The EI system shall be designed to suit the same. The outdoor functions shall be driven by the nearest object controller as decided by railway officer in charge. The details of output functions each object controller is driving shall be submitted by the tenderer.
12. The architecture and distribution of Object controller shall be made line/zone wise so as to result in minimum repercussion to traffic in case of failure of any object control module or the power supply or its connectivity to EI system.
13. The next level signal control circuits like cascading of signal aspects, red lamp protection etc., shall be achievable through software only or as per South Western Railway practise.
14. For all vital inputs/ outputs, going out of EI room's double cutting arrangement shall be provided.
15. The audio-visual alarm shall be available for approach locking, power failure, signal blank, button stuck up etc. for corresponding Command held high for more than a specified duration in EI as specified by Railways.
16. The system shall have provision for accommodating additional 15% of I/O in the form of unused I/O cards slots or the unused bits in installed cards. The system shall have provision for accommodating additional 25% of Logical Bit spares/Timer spares in each CIU/Card File Level for facilitating minor alterations without hardware additions in future.
17. It shall be possible to extract relay room key, crank handles, LC gate controlling key in case of total shut down of system also. The S&T Hut will also be provided with double locking. All the S&T Hut keys are to be treated as relay room keys and same design provisions are to be given. Relay Room opening and closing shall be wired and monitored through the Data logger for cabin and S&T Huts where EI system is installed.
18. The system shall be designed with the concept of "graceful degradation" i.e., failure of any component shall not paralyse the entire system.
19. The healthiness of both main and standby communication and all object controllers shall be displayed on VDUs continuously.
20. In case of failure of system at S&T Hut due to power supply failure or any other reason, it shall be possible to reset the systems at S&T Hut from central EI itself and bring back the entire system to normal working status.
21. In case of locking of any sub –route or signal, an indication shall appear on VDUs indicating the sub route/signal which has got locked.
22. In case of failure of the system, if all or few of the sub routes get locked, it shall be possible to clear all the sub routes at one go, not requiring to clear each route separately

44. Execution of the work

1. EI works as specified in the scope shall be executed in close coordination with the outdoor contract works being executed by other agencies. The contractor shall arrange for competent engineers at site at each active work spot for close liaison with other agencies involved in work.
2. The Signalling Plans/sketch of Yesvantpur Station attached is tentative and are to give only a geographic view of the work place. Extra routes/functions may be required to be designed and as per approved plans.
3. K-RIDE reserve the right to make any alterations during the course of execution of the work, if considered necessary, in the drawings/plans issued including approved signalling plan. No compensation in any form will be admissible on this account. Contractor(s) will have to execute the work as per final plans at the rates quoted by him/them.
4. Tenderer is responsible for obtaining technical system application approval from RDSO vide railway board Ir No.2012/Sig/ATSS dated 03.05.2012.
5. In case the work of commissioning of any station out of four stations is taken up prior to commissioning of any station, then the tenderer has to make his own arrangements, at his own cost, to tie up with the OEM.
6. The commissioning support by OEM for all items supplied by tenderer shall be ensured at least one month before and after commissioning. All teething troubles post commissioning (up to 1 month) must be attended within 1 Hrs.
7. Any special type of Measuring Instruments and accessories required for Commissioning Testing of the installations are to be arranged and brought at site by the contractor at his cost.

8. **Modifications:**

The contractor shall supply any additional equipment without extra cost for any alterations of the works due to any discrepancies, errors or omissions in the drawings or other particulars supplied by him, whether such drawings / particulars have been approved by the Railway or not due to inaccurate information or particulars furnished to the Contractor on behalf of the Railway.

RDSO technical system approval shall be arranged by the tenderer & necessary corrections to comply with the same have to be made by the tenderer. No extra payment will be made for such corrections involving hardware/software changes.

Sketch enclosed along with the tender document is tentative in nature. Additional software work due to change in scope of signal Interlocking plan during the course of execution of the work shall be carried out by the contractor without any extra cost up to 10% increase in routes. However, if hardware augmentation is involved for such changes in scope beyond above mentioned increase in routes and input/output functions, then cost of hardware will be considered for payment provided break up for cost of each type of Hardware is given in Tender offer. This applies up to commissioning of station but not in the warranty period. Fresh FAT to be conducted for each change in signalling plan.

Installation, wiring and interfacing of Operator VDUs, maintenance terminal and embedded PC with EI shall be got done by the tenderer through OEM only.

Connectivity to the EI shall be on optical fiber cable. External isolation for serial ports to be provided by tenderer. Tenderer may be required to arrange for Interim provision (up to 6 months) of operator and embedded PCs, (due to any unforeseen delay of their supply by Railways wherever applicable) to enable Installation, testing and commissioning of stations.

Pre-commissioning check list of supplied equipment duly certified by OEM shall be provided by the contractor before commissioning. Tenderer shall deploy adequate number of competent and trained personnel for work and for maintenance of the system during warranty period as per instructions of Engineer in charge of Railways. Staff nominated for maintenance will be scrutinized. The selected staff only will be permitted for maintenance. The staff will carry their own tools for maintenance.

9. **Training:** Tenderer shall impart

- (a) Training of Railway personnel in installation, commissioning, testing, troubleshoots and in diagnosing the faults using diagnostic tools/ flow charts including boarding and lodging with supply of soft and hard copies of documentation for period as mentioned in the schedule. All logistical support required for training shall be arranged by the contractor
- (b) Training on application software for designing, change in the logics and converting it suitable for system and loading the programme into the working system for alteration of SIP/TOC. The training should be comprehensive with complete document for period as mentioned in the schedule man days. All logistical support required for training shall be arranged by the contractor.
- (c) The quality of training should be of such that at the end of the training, the Railway Personnel should be able to install/commission the equipment in similar or modified layout, do the necessary software and hardware changes required in future, and also organize, locate and rectify the faults besides maintenance. They shall be trained in all aspects of system design, engineering, inspection, testing, execution, commissioning, fault diagnosis operation and maintenance of the system as whole and also all constituent equipment.
- (d) The training courses should, apart from formal class room training, include hands on practical experience and visits to working installation.
- (e) Tenderers to indicate the adequacy or otherwise the duration, place of training, coordination required

10. **Quality Assurance & Software Validation:**

The tenderer shall submit along with the tender the quality assurance control and inspection plan including full details of in house quality assurance organization, procedure and documentation. During the manufacturing process, proper record shall be maintained for the inspection and tests carried out according to this plan. In the event of Railway waving off the inspection all tests provided in the schedule approved by Railway shall be carried out by the quality assurance organization and proper record to the Railway on demand. The tenderer shall submit along with his tender the details of software validation done by on Accredited Agency of international repute. Further, the tenderer shall submit all details of test, certification and validation done to ensure full safety of the system for use of stations for operation of passenger train services as per the technical specification.

11. EI system to be installed at all stations is working in Distributed Architecture. However, scheme may be changed during the course of execution.
12. For better reliability, all vital sub systems like Processor unit, Object controllers shall have separate 110-24 Volt DC- DC converters. DC-DC converters provided for EI shall be segregated for 'A' & 'B' systems along with segregation of cabling and termination for power supply up to DC- DC converters, for all the converters and in N+1 configuration. The typical EI power supply schemes issued by RDSO vide TAN No. STS/E/TAN/3008 or latest shall be followed.
13. The EI system should be designed to suit QN1 and QNA1 24V DC relays.
14. The scope for Provision of EI system includes designing of EI Software (Application Logic, Interface Circuits etc.) including Operator and Maintenance VDU software as per approved signaling plan & Table of control provided by K-RIDE/Railways. The K-RIDE/Railways will check and make necessary corrections and hand it over to the contractor for final preparation of circuit diagram and submission for approval before installation.
15. Design charges for phase works as per Phase signaling plan will be paid as per schedule of work, in case the work is commissioned in multiple phases.
16. Track repeater relays /slot relays /Gate controls relays/ siding control relays/repeater relays shall be of approved type and shall work on 24V DC.
17. After testing and commissioning of the entire installation, "As Made" Design & Documents and Installation details shall have to be supplied as per specification, duly incorporating all particulars for the station. All "As Made" Design and Documents" shall be prepared by the contractor in Autocad 2000 or latest and submitted in Soft Copy (pen drives) and Hard Copy (R.P. Film) in duplicate. Blue prints of the same shall be supplied in desired number as per the schedule.
45. **ESSENTIAL SPARES :**
 - 45.1 All lowest level field replacement module/ assembly/ device units, which shall include all circuit packs/ boards, Cards, modules, terminals, fuses, power supply ancillary equipment, interconnecting couplers/ connectors/cable of each type.
 - 45.2 The scale of Essential spares shall be 10% and 15% of the quantities of Normal Cards and Vital Cards used in the working system respectively subject to a minimum of one.

46. Specification for Tool Kit related to EI

The indicative list of measuring instruments and tools is as follows, which is not exhaustive. Tenderer should include the contents of the Tool Kit along with their offer including any other tool specifically required for handling the equipments supplied in this contract.

1. Crimping tool set
2. Crimp insert set
3. Extract tool set
4. Insertion tool set
5. Location tool set
6. Screw driver adjustable
7. Spanner double ended 33mm
8. Spanner double ended 3/8x1/2"
9. Spanner double ended 5/8 x 3/4"
10. Spanner double ended 7/8x1"
11. Adjustable screw spanner 12"
12. Insulated cutting plier
13. Insulated nose plier
14. Hammer 1 1/2" LBS ball pane
15. Hacksaw frame
16. Electronic soldering iron 230V/60W
17. Digital multimeter (Fluke)
18. AC clamp meter of Suitable range to cover the measurements of all kind of Used Voltages and currents (Fluke or equivalent)
19. Cabinet to store tools

47. Scope of Work under Items related to Electronic Interlocking System Complete is as below.

47.1 Supply Portion of Electronic Interlocking System Complete

Manufacture and Supply of Microprocessor based Electronic Interlocking (EI) system complete as per RDSO Specification No. RDSO/SPN/203/2011 or latest with latest amendments, as per Special Conditions of Contract and Technical Specification enclosed, including all fixtures, interconnection cables and jumper wires, mounting arrangement and accessories to make the EI System functional at stations mentioned in the Scope of Work of SCC. This EI system shall be of Hot Standby with Distributed Architecture. This system should have either relay interface or object controllers to drive field gears. If object controllers are used, it shall be installed at relay room of station. The system shall be designed with Dual Operator VDU of size 85" with industrial grade Embedded Fan-less PC as per RDSO TAN No. STS/E/TAN/3007 Version 1.0 or latest.

The supply includes:

- (a) Supply of commercial grade operator VDU of size 85" full HD including all accessories - 2 Nos.
- (b) Supply of commercial grade operator VDU of size 65" full HD for maintenance terminal - 1 Nos. with Industrial grade Embedded Fanless PC as per RDSO

TAN No. STS/E/TAN/3007 Ver. 1.0 or latest with adequate storage memory to work in Hot-standby mode. The VDUs shall have minimum 4K resolution for 85" monitor and Full HD resolution for 65" monitor with commercial grade suitable for 24/7 operation.

- (c) Design and Supply of 2 sets of hard copies of documents (Application Logic and Interface Circuits) for approval and supply of 2 sets of final approved copy.
- (d) Supply of EI Racks, Relay Racks, Fixtures, mounting arrangements, Interconnecting cables and Jumper wires etc. Relay racks, which are being supplied as a part of this item shall have 15% spare capacity for future use.
- (e) Only OFC based communication equipment should be provided for communication between EI equipment and Operator VDU. OFC/UTP cable switches, protocol converters etc. and any special cards and cables /wires required for OFC based communication system should be supplied for under this schedule item. Only Armoured OFC cable as per railway specification shall be used (supply not included).
- (f) Accessories such as managed Ethernet switch, RS232, isolator etc., as required to interface EI with VDU shall covered under this schedule. The system shall have provision for accommodating additional 15% of I/O in the form of unused I/O cards slots or the unused bits in installed cards.

NOTE:

- (1) Vital I/O Bits are calculated as per the EI Functional Table enclosed below.
- (2) Hardware Configuration mentioned below is inclusive of additional 15% of I/O Bits either in the form of Unused bits in installed cards or unused I/O slots, any other Vital I/O, Non- vital I/O and Read Back Inputs as required to make EI system functional with Dual VDU system as per OEM requirements.
- (3) In case of Siemens Westarce Make, the Quote Should be inclusive of QN1, 50V DC Interface relays, if required.
- (4) Any other materials other than the above mentioned materials, required for making the Electronic Interlocking functional to be supplied as part of this schedule item.

47.2 Supply and Installation of DC/DC converters

DC-DC converters shall be supplied separately for A & B Systems along with segregation of cabling and termination & shall be in N+1 configuration as per RDSO TAN No. STS/E/TAN/3012 dated 10.08.2016 ver.2.0 or latest.

47.3 Supply and Installation of Datalogger

Supply and Installation, wiring, testing and commissioning of Data logger including wiring the External relay contacts. (All the internal variables of EI should be monitored by the data logger.)Data logger with 32 Analog inputs and 512 External Digital inputs along with Protocol converter for Interfacing the EI system and Fault diagnostic software shall be as per RDSO Specification No. IRS-S-99/2006 or latest and as detailed in Technical requirements for Datalogger in next section. Data logging facilities shall conform to 5.1.5 of RDSO Specification No. RDSO/SPN/203/2011 or latest. The tenderer shall take the responsibility to supply Data loggers which are not

only interfaced with EI system but also interface seamlessly with the existing Data logger network.

47.4 Supply and fabrication of table having dimensions 2.5 Mtr x 1 Mtr (Featherlite or Better make) (or dimension as per site requirement) for accommodation of datalogger terminal, maintenance terminal including Printer arrangements. This includes supply of one chair (Godrej PCH7002DX or superior) as approved by Engineer in charge

47.5 Supply and Installation of Panel Operator Console in SM Room **New Modular/Pyrotech or similar or superior company** (as approved by K-RIDE engineer in charge) with control desk for 2 monitors of min 85" size, 2 operators, 2 Nos. of UFSBI/SSBPAC Block panel and on SM Key Cum Counter Box. & one module to be provided for storage in SLAT system - should include space for housing Two nos of Embedded PCs, 2 nos FDMS and their Power supply arrangement for with proper ventilation - Two chairs (Godrej PCH7002DX or superior as approved by officer in charge) to be provided adequate spares as approved by engineer in charge so as to cater for entire codal life of work space with arrangements to fix 2 No. VDUs of 85", SM Key Cum Counter Box, 2 Nos. of UFSBI/SSBPAC Block panel & Axle Counter Reset Boxes, etc. The material of the working surface should be minimum 12 mm thick ASS+ 25mm MDF Board. 2. Structure: Made of heavy duty Extruded Vertical and Horizontal Aluminum profiles of HE9WP grade. The Extrusions shall be duly powder coated with 40+ microns over all surfaces. All sheet metal parts must be finished with a durable, black, electrostatic powder coating. OEM must be FSC certified. The structure shall be rigid enough to withstand BIFMA X5.5: 2014 (Latest Edition) test. 3. Slat Wall Shall be made of approximately 2mm thick Extruded Aluminum (HE9WP aluminium alloy). 4. Shutters & Side Legs: - Front, back shutters shall be of 18 mm Laminated MDF Board with premium finish. Side leg shall be of 25mm of the same finish. Hinges shall have ten year's warranty against manufacturing defects. Proposed console shall meet the VOC emission parameters as per BIFMA X7.1 standard. Proposed console must be Green guard Gold certified. 5. Cable Trays and Wiring: - The desks must be designed with vertical and horizontal cable trays to allow for continuous cable management between the cabinets. Wire shall be routed into the cabinet through gland plate. Proposed console should be RoHS Certified from UL/Intertk

All the materials required for the fabrication and fixing of console shall be supplied by contractor including Lead, Lift and Man-power. Work need to be carried out as per the tentative drawing available at the office of GM/Sr.DGM/K-RIDE and the instruction of site engineer. This item also includes supply of Godrej C13 or better make/model Computer Table (1 No.) for installation of Maintenance VDU of 65" and Godrej Office Executive Chair or better make (2 No.s). (Refer drawing/sketch attached)

47.6 Supply and provision of Earthing & bonding, Surge Protection and System integration as Per RDSO specification No.RDSO/SPN/197/2008 or latest, RDSO TAN No.STS/E/TAN/3012 dated 10.08.2016 ver.2.0, RDSO TAN No.STS/E/TAN/3006 Version1.0 dated 02.11.2012 and/or latest and guidelines issued by RDSO/Railway board for achieving earth value less than One Ohm, using minimum of Six Maintenance Free Earth Pits.

47.7 Supply, Installation and commissioning of Class 'A' protection with Lightning Event Counter as per RDSO spec No. RDSO/SPN/197/2008 and as per details given in Technical specification in following sections, with three years warranty

47.8 **Installation, Testing and Commissioning of Electronic Interlocking System Complete**

Design, Installation, Wiring, Testing and Commissioning of EI Equipments as per RDSO Specification No. RDSO/SPN/203/2011 or latest, including installation of Relay racks and Fixing & wiring of all types of interface relays, termination of interface wires on the CT rack (FTOT) and printing sleeve particulars. The input and output cables/wires (RDSO approved) used for interface wiring of EI shall be made of twisted pair.

This work also includes:

- (a) Installation of EI Racks, Relay Racks, Fixtures, Mounting arrangements, Interconnecting cables and Jumper wires etc. Relay racks, which are being supplied as a part of this item shall have 15% spare capacity for future use.
- (b) Supply and Installation of Powder Coated SM Key Cum Counter Box made of MS Sheet of approved type as per approved drawing of Counter Box.
- (c) Synchronization of EI clock and Data logger clock through CMU.
- (d) Provision of Communication between Operator VDU, Maintenance VDU and CIU/Main EI Equipment.
- (e) Supply and provision of necessary Class B, C and D protection as per RDSO guidelines. Provision of DC-DC converters in N+1 configuration separately for A & B Systems along with segregation of cabling and termination.
- (f) The tenderer shall submit the OEM certificate for the installation as per RDSO prescribed format before commissioning of EI. (OEM certificate is mandatory for making payment.)

NOTE:

- (1) During the stage of execution, if there is any alteration in the approved TOC, up to 20% Positive Variation in Number of Routes, need to be catered within the scope of this item. No additional cost will be given by K-RIDE.
- (2) Fuses, LED indicators for fuses, indoor cable, wire coils, etc. required to wire the various relays and all other miscellaneous materials required for the work shall be supplied by the contractor. Any other materials other than EI modules/card, relays and DC-DC converters required for the commissioning of EI shall be supplied by the contractor.

47.9 **Submission of "As Made" documents for EI:**

The contractor has to supply six sets of documents as mentioned below along with system details, site installation details/drawings, maintenance manual, and Operation procedure in a bounded book as per practice of SW Railway. 'As made' shall be prepared by the Contractor in AUTOCAD 2000 or latest in A3 size. All indoor work details shall be prepared by contractor and submitted to K-RIDE/Railways before testing the circuits. On execution of the work, one copy of the 'As made' check print along with soft copy of the drawings shall be submitted for checking. The final negatives shall be made in tracing sheet and submitted to K-RIDE/Railways for approval. On approval, the contractor shall submit along with the negatives, six sets of documents duly making neatly bounded booklets. Out of 6 sets, 2 sets of drawings and other plans shall be kept in transparent plastic cover (2 sheets back to back in one plastic cover) and handed over to Railways.

The As-made shall include the following:

- (a) Wiring diagrams (Interface circuits)
- (b) Application program listing (Application logic in ladder form)
- (c) Relay/Cable termination particulars
- (d) Input/Output assignment details
- (e) Relay layout and contact analysis chart
- (f) Equipment disposition layout
- (g) Details of power supply arrangement
- (h) Actual boolean equations (note pad/word file), VDU Software for the station, VDU application data for the station, various compilers of the data etc. as per RDSO TAN No. STS/L/SSI/General dt.10.3.2017
- (i) Any other drawing as required by the Railway as per the practice
- (j) All other documentation as per clause No.10 of RDSO specification RDSO/SPN/203/2011 or latest with latest amendment shall be supplied.

Note:

- 1) During the stage of execution, if there is any alteration in the approved TOC, up to 20% Positive Variation in Number of Routes, need to be catered within the scope of this item. No additional cost will be given by K-RIDE.
- 2) Fuses, LED indicators for fuses, indoor cable, wire coils, etc. required to wire the various relays and all other miscellaneous materials required for the work shall be supplied by the contractor. Any other materials other than EI modules/card and DC-DC converters required for the commissioning of EI shall be supplied by the contractor.

Function Table for I/O Bit Calculation:

FUNCTION TABLE FOR EI I/O BIT CALCULATION					
SN	FUNCTION	VITAL OUTPUT		VITAL INPUT	
		NAME	BITS	NAME	BITS
1	Signal 4A	HR, HHR, DR	3	RECR, HECR, HHECR, DECR	4
2	Signal 3A	HR, DR	2	RECR, HECR, DECR	3
3	Signal 2A	HR	1	RECR, HECR	2
4	Route Indicator - 1	UGR1	1	UECR	1
5	Route Indicator - 2	UGR1, UGR2	2	UECR	1
6	Route Indicator - 3	UGR1, UGR2, UGR3	3	UECR	1
7	Route Indicator - 4	UGR1, UGR2, UGR3, UGR4	4	UECR	1
8	Calling-On Signal	Co-HR	1	Co-HECR	1
9	Shunt - Ground Type	HR	1	HECR, RECR	2
10	Shunt - Post Type	HR	1	HECR	1
11	Point	WCR, WNR, WRR	3	NWKR, RWKR	2
12	Track Circuits			TPR	1
13	Crank Handle	CHZR	1	CHR	1
14	LC Gate	LCAR, LCYR	2	LCPR, EKPR	2
15	Axle Counter	Reset	1	VPR	2
16	UFSBI (DL/SL)	LSS-SR, LSS-NR, FSS-RR, FSS-NR	4	ASCR	1
17	FM (Diado)	1R, 2R	2	ASCR	1
18	SLBI (TLBI)	SNR, TAR	2	ASCR, SHZR	2
19	SMR			SMR	1
20	Relay Room Door			RR.DOOR	1
21	TJ Failure			Up TJ, Down TJ	2
22	DC-DC Converter Fail			DC-DC Fail	1
23	Emergency Crank Handle	ECHR-Key	1	EMR.CHR.CR	1

48. In case of RDSO approved OEMs as mentioned above, Detailed Cost-wise and Quantity-wise Break-up for Schedule E items related to Electronic Interlocking System- Supply, Installation, Testing and Commissioning and Spares for these items are not required to be submitted by the Contractor. Supply and Execution of the items related to Electronic Interlocking should be carried out strictly as per the Schedule of works and Quantum of Hardware Cards, Components and Sub-systems and Spares are to be supplied by the Contractor as mentioned in previous para.
49. In case of any OEMs getting RDSO Approval after the date of Tender Uploading and before Tender Closing, Detailed Cost-wise and Quantity-wise Break-up for Schedule E items related to Electronic Interlocking System- Supply, Installation, Testing and Commissioning and Spares for these items need to be uploaded by the Contractor along with his offer. In this case, as per the requirement for each type of System Configuration, Quantity will be deduced by the K-RIDE before finalization of tender and Contractor need to supply the material as per the quantity deduced by the K-RIDE/Railways only.
50. During the stage of execution, additional software works due to change in scope of signal Interlocking plan shall be carried out by the contractor without any extra cost up to the maximum available Input/ Output functions/Hardware Cards of that particular System Configuration. However, if hardware augmentation is involved for such changes in scope beyond above mentioned limit of input/output functions, then cost of supply of requisite hardware will be considered for payment as a new/additional item. Re-Designing and Installation will be paid as under relevant schedule item.

PART-(X)

Technical Requirements of Automatic Fire detection and alarm system

1. GENERAL

1. Automatic Fire Detection & Alarm System (AFDAS) shall consist of all or any of the following:
 - (a) Probe type Bimetallic Heat detectors for Diesel Generator enclosure.
 - (b) UV & IR flame detectors for Diesel Oil Storage room.
 - (c) Heat and Smoke multi sensors for Diesel Generator room, Power Supply Room, non air-conditioned Relay Rooms, ASM Room and other rooms connected with Signalling Installations, as required.
 - (d) Heat and Smoke multi sensors for CCTV Control & Equipment Rooms, Way side Station OFC Room/Quad Repeaters, and other rooms connected with Telecom Installations as required.
 - (e) Linear Heat Sensing (LHS) cable along with its interface module (for cable trays, cable troughs, & cable bunch etc.) or Linear Heat Detection System with its interface module (for cable trays, cable troughs & cable bunch etc.)
 - (f) Aspirating (air sampling) type smoke detector for air-conditioned Relay Rooms. Aspirating (air sampling) type smoke detector for Major Telephone Exchanges, Satellite Hubs, Data Centre location & Main Switching Centre (MSC), Base Station Controller (BSC) for MTRC, Test Room/Telecom Control Room and Main OFC Junction Equipment Room.
 - (g) Control Panel - For reading the signals from sensors/detectors, giving audio/visual alarms.
 - (h) Other Items (OI) - like Manual Call Points at the entry and exit of various rooms, connecting cables, relays, Audio Visual alarms etc. necessary for commissioning & reliable operation of the AFDAS.
2. The AFDAS shall be modular in structure, so that any fault in any of the modules can be set right by simply replacing the Faulty Module, with a spare.
3. The AFDAS shall be self-checking & diagnostic type. It shall continuously monitor the health of the sensors/ detectors & the complete system including battery. The data regarding health & event shall be logged in the system with date & time stamp, which can be downloaded to a PC/ Laptop at later stage. The system should have capacity to store data for up to a minimum of 512 fire events and other events. The Control Panel shall be networkable to the Zonal/Divisional Railway headquarters preferably over TCP/IP and shall have clock synchronization facility
4. The detectors shall be suitable for installation in electrical cabinets, transformers, inverters, cable trays, electronic equipment, power equipment rooms, relay rooms, or any other enclosed areas, which are vulnerable for fire as deemed fit by Indian

Railways.

5. The system shall be suitable to detect fire/ fire like situation in relay room, power equipment room, Diesel generator room, Oil Storage room, ASM room (inside Operating/Maintainer panel and change over panel) and other rooms pertaining to S&T installation, electronic equipment, electrical wiring etc., and generate audio visual alarms.
6. The AFDAS shall work satisfactorily & reliably over the entire range of following environmental parameters:
 - a. Temperature range shall be as per the limits specified in the concerned Para.
 - b. Humidity 0 to 85 %
 - c. In dusty, sandy, and desert conditions, the OEMs shall specify the frequency for cleaning of the detectors, after installation to avoid false alarms.
7. Loop controllers shall have built in interference nullifier so that separate EMI control circuit is not required. The loop distance may be a minimum of 1.2 Km or as per the recommendation of the manufacturer.

or

Radio frequency /electromagnetic interference and electromagnetic compatibility must be available. The limits for EMI shall be 2KV ($\pm 10\%$), 5 KHz ($\pm 20\%$) for Power supply ports and 1KV ($\pm 10\%$), 5 KHz ($\pm 20\%$) for input/output signal, data and control ports (IEC 61000 4-4).

8. In case it is felt necessary by the railways to add more or additional sensors to the existing Fire Alarm System, the sensors / detectors covered in this specification shall be backward and forward compatible for future expansions.
9. The Automatic Fire Detection and Alarm System covered in this specification shall also be able to generate requisite commands to activate 'Automatic Fire Suppression System', where provided.
10. It shall be possible to extend the alarm to remote location.
11. The working of the equipment shall not cause interference to other electrical /electronic circuits/systems.
12. The AFDAS shall have provision to provide sufficient sets of Programmable Potential Free NO/NC contacts (minimum 3 NO and 3 NC for each room where AFSS is installed), to trigger the Automatic Fire suppression system through logical function as per RDSO/SPN/218/2016 or latest pertaining to Signalling Installations, if provided, switching off the power supply to power equipment /relay room (if required) and for interfacing with the existing Data Logger system. The Current carrying capacity of NO and NC contacts shall be at least 500 mA.
13. The system shall not degrade the performance of relays, power equipment, wiring, cables etc. when subjected to Fire Detection & Alarm process.
14. The system shall be capable of working in non-air-conditioned environment in the installation except for Aspirating (air sampling) type smoke detector. It shall be suitable for installation on AC/ DC electrified and non-electrified sections. It shall be suitable in all areas including where locomotives having thyristor controlled single phase or 3-phase induction motors haul passenger or freight trains and where

chopper controlled EMU stocks are operated.

15. The response time for alarm generation from the time of detection by sensors/detectors shall not exceed ten seconds (NFPA 72 Edition 2016 Para 10.11.1). It shall reliably transmit the detected signal to the Control Panel, so that it can translate this detected signal into suitable alarm signal and warn the railway personal for taking corrective action.
16. It shall Indicate or display the location of fire, status of detectors with all stages of alarms.
17. It shall be possible to expand the system by minimum 20% in future in terms of various types of sensors subject to minimum of two sensors in each category.
18. Power Supply Arrangements for AFDAS: The primary source of supply shall be 110V/230V AC to be given by K-RIDE/Railways. In case, failure of primary power supply the system shall work on Secondary power source (battery backup) as part of the system. The minimum cut off voltage for primary shall be specified by OEM. Whenever the primary power supply fails to provide minimum voltage required for operation, the secondary source of power supply shall automatically provide power within 10 seconds (Clause 10.6.6.1 of NFPA 72 Edition 2016).
19. The System design shall not incorporate use of any radioactive material. A declaration shall be submitted by the supplier in this regard at the time of product approval.
20. It should be feasible to cover both Signalling & Telecom installations with Single Automatic Fire Alarm & Detection System and common control panel where both installations are located close by like way side stations or any other location. Otherwise independent Automatic Fire Alarm & Detection System shall be provided.
21. In case Automatic Fire Alarm & Detection System is provided for a signalling or telecom installation, it should be feasible to extend to nearby signalling or telecom installation.
22. The AFDAS may consist of Probe type Bimetallic Heat Detectors, UV&IR Flame Detectors and Heat & Smoke Multi Sensors which shall be installed, at critical locations to detect smoke, temperature rise & absolute temperature & send the signal to Control Panel. The AFDAS shall be an addressable system with facility to program cross zoning of detectors. In addition, Linear Heat Sensing cable or Linear Heat Detector shall be laid in cable trays, battery boxes, power equipment etc. for heat detection & sending the signal to the Control Panel through an Interface. On getting the signals from above detectors/ sensors, Control Panel shall give Audio Visual Alarms to the railway personnel to actuate Fire Extinguishing System manually. The AFDAS shall also have a feature to trigger 'Automatic Fire Suppression System' (if provided) when the suppression system is interfaced with AFDAS.

2. TECHNICAL REQUIREMENTS

2.1 DETECTORS IN DIESEL GENERATOR ENCLOSURE/OIL STORAGE ROOM

2.1.1 PROBE TYPE BI-METALLIC HEAT DETECTOR FOR DIESEL GENERATOR ENCLOSURE

1. Probe type bi-metallic resettable type heat detectors shall be used for diesel generator enclosure.
2. The actuating temperature shall be as per the model number offered by the manufacturer. Same shall be considered in type/acceptance test. The manufacturer may specify as many models as possible. The probe type bi-metallic heat detector shall be chosen by the purchaser such that the temperature rating of the detector shall be at least 11°C above the maximum operating temperature of the diesel generator
3. It shall be able to detect temperature and shall communicate alarm signal to Control Panel when temperature rises above the defined value.
4. The insulation resistance of the detector shall not be less than 10M ohm.

2.1.2 UV and IR FLAME DETECTORS FOR OIL STORAGE ROOM

1. Diesel Oil Storage room shall be provided with UV and IR flame detector to facilitate diesel fire detection.
2. The range of flame detector shall be at least 10m. The response time of the flame detector shall be less than 10 seconds.
3. The flame detector shall be resettable.
4. It shall not give false alarm under solar or electrical light conditions.
5. It shall be UL or FM or Vds or LPCB approved/listed.
6. The flame detector shall be able to communicate the fault and fire event to the control panel.
7. The flame detector shall be suitable for operation in a temperature range of 0-49°C.
8. The insulation resistance of the flame detector shall not be less than 10M ohm.

2.2 HEAT & SMOKE MULTI SENSOR FOR POWER EQUIPMENT ROOM, BATTERY ROOM, ASM ROOM, NON-AIRCONDITIONED RELAY ROOMS, DIESEL GENERATOR ROOMS

1. Heat & Smoke multi sensor shall be robust, rugged & suitable for surface mounting.
2. Heat & Smoke multi sensor shall incorporate state of art optical chamber providing efficient & accurate detection of fire with high level of reliability & high immunity to spurious signal. The sensitivity of the Heat & Smoke multi sensor shall vary with the ambient conditions including dust particles to reduce false alarms.
3. Heat & Smoke multi sensor shall incorporate integral LED indicator to show the status of the detector.
4. Each Heat & Smoke multi sensor shall have suitable indications for indicating Normal Healthy Mode & Alarm Indication mode.

5. The detector's alarm condition shall be visible from a distance of 6 Meters (normal condition as per clause 3.1 of IS: 11360) and shall be visually different from the indications of the other conditions.
6. The insulation resistance of the detector shall not be less than 10M ohm.
7. Failure of any indicator shall not prevent the detector from emitting fire signal
8. indicating the existence of fire.
9. The Detector / devices must have inbuilt fault isolator or alternate arrangement at detector level which shall isolate the detector in case of short circuit or open circuit in the loop.
10. The detectors shall be addressable and resettable type.
11. It shall detect the fixed heat above 58°C and the rate of temperature rise (between 6°C/minute to 11.1°C/minute) independently in addition to the photo electric smoke detection.
12. The detectors shall be provided with means for mounting (on ceiling / wall) securely and independent of any support from the attached wiring.
13. Plastic, if used for detector, shall not start softening, deforming, or melting at a temperature lower than 95°C as per Clause 4.2 of IS: 2175-1988.
14. Smoke detector in this multi-sensor shall be able to detect smoke and shall communicate alarm signal to Control Panel when optical density of smoke/obscuration falls within the limit as follows:

Limit	%obs/m	%obs/ft
Lower	1.6	0.5
Upper	12.5	4.0

15. The ratio of highest r. t. v. and lowest r. t. v. shall not exceed 1.6 in the least favourable direction, i.e., the direction opposite to the beam of LED.
16. The smoke and heat multi sensors can be provided in power equipment room, battery room, ASM room, non-air-conditioned relay rooms, diesel generator rooms, CCTV Control & Equipment Rooms, Way side Station OFC Room/Quad Repeaters and other rooms of S&T installations, as required

2.3 ASPIRATING (AIR SAMPLING) TYPE SMOKE DETECTOR

- 2.3.1 The air sampling-type detector system shall be able to withstand dusty environments by onboard monitored air filtering, Auto cleaning facility in optical chamber, electronic discrimination of particle size or other listed methods or combinations thereof. The detector should be capable of providing time delays (< 10 seconds) of alarm outputs to eliminate nuisance alarms due to transient smoke conditions. The detector should also provide facilities for the connection of monitoring equipment for the recording of

background smoke level information necessary in setting alert and alarm levels and delays. It shall have event logging facility with date and time stamp.

2.3.2 Air Sampling Type detector shall use LASER or High-power LED. This type of detector shall use piping or tubing distribution network that shall run from the detector to the areas to be protected. The aspiration fan in the detector housing shall draw air from the protected area and back to the detector through air sampling ports, piping or tubing. At the detector, the air shall be analyzed for fire products.

2.3.3 The detector shall have the capability of generating four alarm signals depending upon level of smoke detected, for example

Example (1):

Stage 1 – 0.5 to 0.95% obs/m

Stage 2 – 1.0 to 1.45% obs/m

Stage 3 – 1.5 to 1.95% obs/m

Stage 4 – $\geq 2.0\%$ obs/m

Example (2):

Stage 1 – 30% of Alarm Stage 4

Stage 2 – 50% of Alarm Stage 4

Stage 3 – 70% of Alarm Stage 4

Stage 4 – $\geq 2.0\%$ obs/m

2.3.4 The value of the smoke levels may be adjusted depending upon the site conditions.

2.3.5 The piping or tubing to air sampling ports shall be laid depending upon the floor area detailed as below:

2.3.5.1 Required number of sampling point shall be provided on either side of each – relay rack, cable termination rack, Air Conditioner, 230V AC Used and unused points etc.

2.3.5.2 Maximum transport time from the most remote port to the detection unit of an air sampling system shall not exceed 60 seconds.

2.3.6 Minimum sensitivity settings above ambient airborne levels for the air sampling system installed shall be as follows:

2.3.6.1 Alert condition: 0.2 percent per foot obscuration (effective sensitivity at each

port).

2.3.6.2 4.4.5.3.2 Alarm condition 1.0 percent per foot obscuration (effective sensitivity at each port).

2.3.7 It shall be suitable for operation in a temperature range of 0-49°C.

2.3.8 The aspiration type smoke detector should be UL or FM or Vds or LPCB listed/approved.

2.4 PIPING STANDARDS

1. The pipes used in the pipe network shall be made of CPVC and shall be listed/approved by UL or FM or Vds or LPCB or tested with appropriate equivalent standard to cater for ceiling temperature of 69°C. The pipe and their assemblies such as couplings, unions, elbows, tees, end caps, capillary tubes, sampling ports, mounting brackets shall be as per the recommendation of manufacturer of Aspirating (Air Sampling) type smoke detector.
2. All distribution piping shall be installed by qualified individuals using accepted practices and quality procedures.
3. In cabinet and above cabinet sampling shall also be planned as per request of the purchaser.
4. The system integrator shall carry out the piping design and validate the same with a hydraulic flow calculation generated by using the UL or FM or Vds or LPCB approved software. The appropriate fill density shall be arrived at based on the same.
5. The design & calculation shall be checked & certified by manufacturer/manufacturer trained design engineer.
6. Plans and calculations shall be approved prior to installation.

2.5 LINEAR HEAT SENSING (LHS) CABLE

1. Temperature sensitive cable also known as Linear Heat Sensing Cable shall be laid in all cable trays located in Power Equipment room, Relay room and Telecom room. Signal about alarm temperature shall be sent to Control Panel by LHS interface module attached with cable system.
2. Linear Heat Sensing cables shall be of temperature sensitive insulated wire type.
3. This linear heat sensing shall be in the form of continuous cables consisting of conductors / cores and shall be of analogue type.
4. Each core of analogue Linear Heat Sensing cable shall be insulated with a negative temperature coefficient material (Clause 5.1.1.4 of IS: 2189-2008). An outer sheath of high temperature, flame retardant PVC insulation, shall protect the cores. The outer sheath or metallic braid shall not affect the performance of the heat sensor
5. The Linear Heat Sensing cable for each zone / room shall be connected to an electronic interface module, which shall sense the temperature variations by

continuously monitoring the resistance of the negative temperature coefficient core insulation. The electronic interface module shall be located suitably in the area being protected.

6. The analogue linear heat sensing cable of every zone shall be continuously monitored for open and short circuit. A breakage, disconnection or a short between cores shall initiate a FAULT alarm on the fire alarm panel of Control Panel.
7. LHS cable shall be resettable type.
8. The design of the analogue, linear heat sensing cable and corresponding electronic sensing circuits shall be such that the cable length and the number of required loops should be set up to provide optimal coverage for the desired region with cable length ranging from 10m to 200 m. The system shall be designed to have an optimum sensitivity.
9. For a given length of sensing cables it shall be possible to set the alarm temperature at 70°C with an Interface Module and with a tolerance not to exceed $\pm 8.3^{\circ}\text{C}$.
10. The Linear heat sensing cable should have strong capability to withstand the mechanical damage, tensile, water, corrosion and electromagnetic interference.
11. Linear heat sensing cable should be UL or FM or Vds or LPCB approved/listed.

2.6 LINEAR HEAT SENSING (LHS) INTERFACE MODULE

1. LHS Interface should be a microprocessor/microcontroller/PLC based device that communicates between LHS Cable and Control Panel. It should be an intelligent device that will monitor LHS cable for continuity and over temperature fire signatures. Performance of the linear heat sensing cable along with its interface module shall be immune to changes in ambient temperature.
2. An increase in temperature at any location along the LHS cable's length shall lower the resistance between conductors in the cable. The change in resistance shall be detected by the interface module, which will trigger an alarm at the Control Panel if the temperature rises above a pre-set threshold.
3. The LHS interface shall be able to distinguish between a Short Circuit Condition & an Actual Fire Event in order to prevent unwanted activation of fire alarm system, in case of an accidental short circuit fault by damage to the sensor or field wiring.
4. The LHS interface shall supervise the sensing cable for alarm temperature condition, open & short circuit to generate a fault condition which shall be displayed on the interface module faceplate by the 2 LED indicators: FIRE LED & FAULT LED.
5. The LHS interface module shall be suitable for operation in a temperature range of 0-49°C.

6. Linear heat interface module should be UL or FM or Vds or LPCB approved/listed.

2.7 LINEAR HEAT DETECTOR (LHD) and its interface module

1. Temperature sensitive detector also known as linear heat detector may be laid in all cable trays located in Power Equipment room and relay room. Signal about alarm temperature shall be sent to Control Panel by LHD interface module attached with Linear Heat Detection system.
2. Linear Heat Detector shall be of temperature sensitive hollow metallic pneumatic tube type.
3. The Linear Heat Detector should have strong capability to withstand the mechanical damage, tensile, water and corrosion and electromagnetic interference. The LHD shall be made of hollow tube of non-corrosive metal/alloy.
4. The Linear Heat Detector for each zone / room shall be connected to an electronic interface module, which shall constantly monitor the pressure inside the hollow metallic tube (LHD) and sense the temperature variations by continuously monitoring the pressure. The change in pressure shall be detected by the interface module, which will trigger an alarm at the Control Panel if the temperature rises above a preset threshold. The electronic interface module shall be located suitably in the area being protected.
5. The linear heat detector of every zone shall be continuously monitored for breakage and obstruction. A breakage, disconnection or obstruction shall initiate a FAULT alarm on the fire alarm panel of Control Panel.
6. LHD shall be resettable type. The LHD shall be reusable after detecting the alarm condition.
7. The LHD shall provide optimal coverage for the desired region with detector length ranging from 10 m to 200 m or more. The system shall be designed to have an optimum sensitivity.
8. For a given length of LHD it shall be possible to set the alarm temperature at 70°C with an Interface Module and with a tolerance not to exceed $\pm 8.3^{\circ}\text{C}$.
9. The LHD interface shall supervise the detector for alarm temperature condition and damage to generate a fault condition which shall be displayed on the interface module faceplate by suitable means.
10. The LHD interface shall be suitable for operation in a temperature range of 0-49°C.
11. Linear heat Detection system (detection tube and its interface module) should be UL or FM or Vds or LPCB approved/listed.

2.8 CONTROL PANEL

1. Detection, actuation, and control system shall have provision for automatic as well as manual operation. Provision for manual operation shall also be provided in addition to automatic operation.

2. The Control Panel shall be the central processing unit of the system, receiving and analysing signals from Probe type bimetallic heat detectors, UV&IR flame detectors, Heat and Smoke multi sensors, LHS/LHD Interface, Aspirating Type Smoke Detectors and Manual Call Points, for providing audible and visual information to the user.
3. It shall have suitable audio-visual alarms for drawing attention/indicating various events.
4. It shall also have the capability to electronically/electrically activate and release Fire Extinguishing System, if used any.
5. The Control Panel should normally be located in Station Master's Room or as per requirement of purchaser.
6. The Control Panel shall have provision to provide sufficient input ports for connecting various sensors/detectors along with their interfaces, if any, & shall have provision to provide sufficient output ports for controlling fire extinguishing system, operating/switching off electrical units and shall have provision for remote monitoring in network. The system shall be approved by UL or FM or Vds or LPCB. The software shall be able to monitor the health of each detector and other devices along with control panel. It shall also have clock synchronization facility.
7. There shall be preferably one Control Panel for a station. However, at stations having bigger relay room & power equipment room deploying a greater number of sensors/detectors, more than one Control Panels can be provided but there shall be a main Control Panel also to control fire extinguishers, to provide alarms, for user interaction etc. of the entire installation through the individual Control Panels.
8. The control panel shall be designed to work on power supply of 110V/230V AC +10%, -15% with DC battery backup of adequate capacity. The control panel shall have inbuilt charging facility for DC battery backup for at least 24 hours for operating the system at quotient load and then 15 minutes under fire or emergency condition at maximum connected load (Cl. 10.6.7.2.1.2 of NFPA 72 Edition 2016). Addressable modules can be used if required to connect electronics of LHS interface module and Aspiration Type Smoke Detector to the control panel.
9. The Control Panel shall have means for the user to visualize and interact with the complete Automatic Fire Detection and Alarm System layout through a user-friendly software executable on a standard Windows based Personal Computer.
10. The front panel of the Control Panel shall have the facility of buzzer silence, alarm silence and alarm activate, lamp test & reset. The front panel shall also indicate the status like fire, fault, disable, test, supply, primary supply fault, secondary supply fault (battery fault) and earth fault by respective LEDs/other suitable means.
11. In case of low battery, the system shall give audio visual indication in the control panel.
12. The Control Panel shall be able to communicate and display the exact number of the Sensor, which has activated the Fire Detection System, for pinpoint location of the seat of fire.
- 13.4.9.13 It shall be possible to download data and extend alarms from Control Panel through suitable ports like RS485/RS232/USB/TCP/IP into a PC/Laptop at the installation and remote location operating on Windows platform. The software for downloading and analysing fault data shall be provided & shall be compatible with the latest windows operating system.
- 14.4.9.14 Audio Visual Indication shall be provided on the control panel and get activated in case of fire/smoke, trouble/fault and for supervisory functions. The audio

indication may be from piezo electric buzzer and visual indication may be LED indication and/or LCD display.

15. Operating devices such as system isolate switches and ancillary equipment; including shutdown equipment; dampers and door closures, required for successful system performance should be considered integral parts of the system. All ancillaries should incorporate manual reset facilities. The exact number of controls required shall be specified by the purchaser as per the site conditions.
16. The software preferably should have the capability for the following 4 levels of actions:
 - a. Level 1 – When Stage 1 signal is received from aspirating type smoke detector or an alarm is received from single detector wired in cross zoned manner, it shall activate an audio-visual indication in control panel.
 - b. Level 2 – When Stage 2 signal is received from aspirating type smoke detector it shall activate audio visual alarm (Hooter and Strobe) in the SM Room.
 - c. Level 3 – When Stage 3 signal is received from aspirating type smoke detector or an alarm is received from manual call point; it shall activate all audio-visual alarms (Hooter and Strobe) to alert Railway Staff for extinguishing the fire and shutting of the power supply of signalling and telecom system, if required.
 - d. Level 4 – When Stage 4 signal is received from aspirating type smoke detector or an alarm is received from any other detector such as cross zoned multi sensor, cross zoned probe type bimetallic heat detector, cross zoned UV&IR Flame detector and independent LHS/LHD module shall initiate all audio visual alarm (Hooter and Strobe) within 10 seconds and the automatic suppression system, if provided shall get activated after a time delay adjustable by user up to 10 minutes in multiples of 0.5 minutes.
17. The control panel should have provision to connect a GSM module and the system(s) shall send SMSs on GSM network to not less than 5 preselected GSM mobile numbers in case of Level 2, Level 3 and Level 4 signals or as desired by the user. The mobile numbers shall be configurable. SMS shall be generated within 30 seconds of the control panel receiving the detection signals and if the sending fails, subsequent sending of SMS shall be tried by the system immediately. The SIM required for the GSM modem shall be provided by the purchaser. The GSM modem shall be from reputed make and compatible to Quad-band GSM 850,900, 1800 and 1900 MHz. It shall work on power supply of the AFDAS with suitable power supply adapter. It shall be able to withstand operating temperature 0°C to 49°C and humidity up to 85%. The GSM Module shall be an optional item and shall be supplied as per request of the purchaser.
18. The Audio Visual Indication of Control Panel shall have means to indicate the room i.e. Relay Room or Power Equipment Room or DG Room etc., from where the alarm situation has been reported and shall also indicate the location of sensor in that room which has reported the alarm situation. The Control Panel shall activate the fire extinguisher, if used any, of that room only for extinguishing the fire.
19. The front panel shall have character display (LED/LCD) and alphanumeric keyboard.
20. For Signalling installations at major yards (more than 400 routes and important Junction stations) control panel must have the provisions for working in degrade mode, i.e. during the failure of communication between loop control circuitry and CPU of the control panel shall operate the audio-visual and other output devices in case of an alarm is detected.

21. For Signalling installations at smaller yards (less than 400 routes and non-critical stations) control panel without degrade mode may be used on discretion of the purchaser.

2.9 Audio Visual Alarm (Hooter and Strobe):

1. Audio visual alarm (Hooter and Strobe) shall be provided with Control Panel where required.
2. Audio visual alarm system (Hooter and Strobe) shall get activated in case of fire/smoke.
3. Visual Alarms (Strobe): It shall be preferably flashing type RED/WHITE Color.
4. Audio Alarms (Hooter): It shall be preferably with Piezo-electric type sounder. The sound level shall be preferably adjustable type up to 90 dB at a distance of 1m.
5. Audio and Visual alarms (Hooter and Strobe) can be extended to ESM duty room subject to condition that it shall not be beyond the maximum loop distance.

2.10 FIRE SURVIVAL CIRCUIT INTEGRITY CABLES

1. The electrical characteristics of all cable, such as voltage drop, current carrying capacity, impedance and, where appropriate, ability to transmit data shall be suitable for the system.
2. The Circuit Integrity cable specification for AFDAS is as follows:
3. Armoured copper cables of minimum 2Core x 1.5 sq.mm having cross linkable Low smoke halogen free inner & outer sheath, 1000V rated, twisted shall be used when the entire circuit is not within the same building.
4. Unarmoured copper cables of minimum 2Core x 1.5 sq.mm having cross linkable Low smoke halogen free sheath, 500V rated, twisted with ATC un insulated circuit protective conductor shall be used when the entire circuit is within the same building.
5. Armoured and unarmoured shall have anti-rodent outer sheath with Low Smoke Properties.
6. Armoured & unarmoured (CI) cables should meet fire performance test under simultaneous action of Flame, water stress and impacts on single sample at 950°C for minimum 2 hours, certified by LPCB or equivalent. Vendor shall submit certificate for the same.
7. The cables used shall be exclusively for fire detection system. The multi-core cables shall not be shared for other low voltage or high voltage circuits.
8. Cables connected to detectors shall be given 'S' loop on both the sides of the detectors which shall be properly clamped to the ceiling. Loop shall also be left where cables connect sounders, panels, dampers, etc. Appropriate 2 hours fire rated glands

shall be provided where the cable enters the junction box.

9. All the cables shall be tagged with colour band for proper identification.
10. The cable manufacturer should provide test certificate related to the manufacturing of fire-resistant wires & cables from UL or FM or Vds or LPCB or BRE Global or any recognized lab by Government of India. The vendor shall also give self -certification in this regard

2.11 MANUAL CALL POINTS

1. Manual call points must be mounted visibly along escape and rescue routes (e.g. exits, passageways, stairwells) and be easily accessible.
2. It shall be installed at a height of 1400 mm \pm 200 mm measured from the middle of the manual call point to the floor.
3. Manual call points must be sufficiently lit with daylight or another light source (including emergency lighting). Lighting shall be provided by the purchaser.
4. It shall be addressable and resettable.
5. Visual indication of normal operation and activated operation shall be available.
6. It shall have inbuilt fault isolator or alternate arrangement which shall isolate the Manual Call Point in case of open/short circuit fault within it.

2.12 CROSS ZONING

1. Two adjacent detectors at a particular location shall be addressed for different zones.
2. If only one detector is triggering the control panel, it shall give audio visual indication in the control panel.
3. If Air Sampling Type Detector is provided in the relay room, then stage-3 signal shall be considered as fire like situation. Cross zoning is not applicable for this detection system.
4. If both the adjacent detectors are triggering the control panel, then fire like situation shall be accepted and fire alarm system shall act accordingly.

2.13 SITING AND SPACING OF DETECTORS

1. A minimum of two probe type bi-metallic heat detectors shall be provided inside the Diesel Generator enclosure. Each detector shall be addressed /wired in cross zoning manner.
2. A minimum of two UV&IR flame detectors shall be provided in the Diesel Oil storage rooms. The inter-distance between two UV&IR detectors shall be at 10m subject to a minimum of two numbers in a room. Each detector shall be addressed /wired in cross zoning manner.
3. One number Smoke and heat multi sensor shall be provided on either side of each relay rack, cable termination rack, each IPS equipment, each power panel, Change over panels, Operating Panel, Maintainer Panel, 230V AC Points used or unused, above Air Conditioner and other locations where fire like situation can arise. Adjacent sensor shall be wired/addressed in different zones. If one detector only identifies fire like situation, then control panel shall provide only audio-visual indication at control panel. If both the

adjacent detector provides the trigger for alarm, then the control panel shall treat as fire like situation.

4. Manual call points shall be provided at each entrance/exit.

2.14 SPARES

The following mandatory spares shall be supplied for each installation:

1. 10% for modules, detectors, and loop cards, subject to minimum of one number for each installation.
2. The CPU card and Power Supply card, minimum one number as spare shall be provided for every five installations, subject to a minimum of one number for less than five installations.

2.15 FIRE SUPPRESSION

For fire suppression, railways shall provide one 4.5 kg capacity, IS 2878:2004, carbon dioxide extinguisher for every 100 m² of floor area or part thereof with minimum of two extinguishers so located as to be available within 10 m radius in addition to Automatic Fire Suppression System.

K-RIDE

SECTION-8C

Safety, Health and Environment (SHE) Manual

A: Safety, Health, Environment (SHE) and Social Obligations of the Contractor

1: Safety, Health, Environment (SHE) and Social Obligations of the Contractor

1.1 Governing Law:

The contract compliance documents shall be governed by the laws and byelaws of the Union of India, the Karnataka Government and the subject local bodies. The competent courts of jurisdiction as mentioned in the Special Conditions of Contract shall have exclusive jurisdiction in all matters in connection with this contract.

1.2 Statutory Compliance:

The Contractor agrees to abide by all the existing laws of all the statutory authorities and bodies and further agrees that the prices quoted include all the costs for liabilities under the existing laws and acts, unless otherwise mentioned. All such laws may or may not have been explicitly stated in this contract document.

The Contractor shall be aware of all laws, ordinance, codes, rules and regulations in any manner affecting those employed on the Works or the materials used in the Works or in any way affecting the conduct of the Works and of all orders and declarations of bodies or tribunals having any jurisdiction or authority over the Work.

- The Contractor shall at all times himself give all notices, observe and comply with and shall require all his its supervisors employees, subcontractors, to observe and comply with all such applicable laws, ordinances, rules, regulations, orders and decrees in effect or which may become effective before completion and acceptance of the Works, and shall protect and indemnify the Authority against any claim of liability arising from or based upon the violation of any such law, ordinance, code, rule, regulation, order or declaration, whether by himself, his its employees or his its subcontractors or any other person or organization employed for or upon the Work.
- In case the Contractor observes that any requirement of the contract documents varies with such laws, ordinances, codes, rules, regulations, orders or declarations, he shall promptly notify the Authority in writing and shall not proceed with any Work affected by such variance without written instructions;
- The contractor shall prepare a register of applicable requirement and status of EHS legal compliances considering proposed construction activities and site-specific conditions before commencement of activity (ies) for necessary actions to comply with.

1.3 Permits and fees:

Unless otherwise provided in the contract documents, the Contractor shall secure and pay for all permits, government fees, and licenses necessary for the execution and completion of the Works and requisite certificates. The required permits will be secured by the Contractor prior to commencing the works and a copy of all such documents shall be submitted to the Authority.

1.4 Safety, Health and Environment (SHE)

1. The contractor shall, throughout the duration of the contract, be responsible for management of safety, health and environment (SHE) and deploy qualified personnel and management committee to manage these aspects;

2. The Contractor shall at all times comply with provisions of the SHE management plan (EMP) which includes the following but not limited to;
- a) All the workers must use adequate personal protective equipment's (PPEs) such as safety helmet, safety shoes, safety glasses, safety harness and gloves etc. as required for different construction activities.
 - b) Tool-box talks should be undertaken daily before starting the routine construction activities. A suitable format for recording the tool-box talk should be filled and maintained at a construction site by the site safety in-charge or site manager.
 - c) Areas being used for activities such as welding, bar cutting, bending, excavated areas and material stacking areas should be barricaded with a barricading tape.
 - d) Adequate safety signages indicating use of PPEs, different hazards etc. should be conspicuously displayed in local language (kannada/hindi) at adequate locations within a construction site.
 - e) Walking pathways for the workers and the drive-ways for the construction vehicles should be kept separate and properly marked.
 - f) At areas in a construction site, where work such as welding, cutting is carried out with aid of electrical power, proper care should be taken so that electrical wire with open joints are not spread on ground in haywire condition posing risk of electrocution and trip hazard to workers.
 - g) Vehicle parking areas should be maintained outside the areas of construction activities and should be conspicuously marked.
 - h) Adequate lighting arrangements should be made within the construction area if construction activities are undertaken after sun set or in absence of day light.
 - i) Heavy equipment's or other earthmover equipment's must be equipped with alert siren for reverse gear.
 - j) Flammable materials such as diesel if stored in bulk quantities should not exceed 900 liters. Drums used for diesel storage should not be placed on unpaved area and open to sky condition. Smoking, lighting or burning activities must be completely prohibited within the radius of 25 m from the location of diesel storage or other highly flammable materials;
 - k) CO2 fire extinguishers and buckets filled with dry sand should be maintained at appropriate locations at a construction site.
 - l) At least 2 first aid kits should be maintained at any construction site and workers should be made aware of whom to contact in case of injuries requiring first aid. First aid kit should be kept in charge of a responsible person who shall be readily available during the working hours. Supervisors at site should have obtained a formal first aid training.
 - m) The contractor shall prepare an emergency response plan and train all workers on the appropriate actions to be undertaken during emergency situations (e.g. earthquake, fire)
 - n) A site-specific emergency contact numbers which should include, nearest police station, hospital, fire station and the site in-charge should be conspicuously displayed.
 - o) An ambulance van or an arrangement with a nearby hospital should be made for transportation of serious cases of accidents or sickness of any worker/s.
 - p) Relevant documents should be maintained by the site managers at a construction site as required under Building and other Construction Workers (Regulation of Employment and Conditions of Services) Act, 1996.
 - q) No worker employed at a construction site shall be required or allowed to work continuously for more than fifteen hours a day inclusive of intervals of rest or sixty hours in a week.

- r) No worker shall be required or allowed to work for more than fourteen consecutive days unless a rest of twenty-four hours is given for rest to such worker.
- s) Standard operating/working procedures with respect to safety should be implementing for undertaking works such as working in confined spaces, working at heights, lifting of heavy parts with cranes and other lifting equipment's.
- t) Lifting equipment's (like cranes, slings etc) should be inspected thoroughly as per standard inspection procedures. Copy of such inspection records should be kept readily available for review with the respective equipment's.
- u) In addition to the aforementioned construction activities, adequate safety measures, as required, during different phases of project development shall be implemented;
- v) Conduct safety audit at periodic intervals and submit the report to the Authority. The report shall outline key findings and corrective actions (if any);
- w) Ensure that hazardous material (paints, lubricants and oils etc) which are brought to the Project site and hazardous wastes (used/waste/left over paint, paint and oil soaked rags/material, empty oil/paint drums/carbuoys, filters, batteries, used hydraulic oil etc.) generated at site (both during construction and operation) are: stored under segregation and containment; handled/used with appropriate care and personal protective equipment; and disposed off through entities authorized to handle and dispose hazardous wastes;
- x) Where applicable and relevant implement the condition for Forest Clearance (FC), NOC from National Board for Wild Life (NBWL), respective CRZ management authority and respective State Pollution Control Board, permission of tree(s) removal from non forest area and other provisions of the environment management plan (EMP) which includes the following but not limited to: (a) provision of slope protection of open and excavated areas; (b) provision of storm water runoff drainage; (c) stockpiling of construction materials shall not impact or obstruct the water drainage; (d) stockpiles shall be covered/protected to prevent dust generation and erosion; (e) construction activities near sensitive receptors shall be limited during daytime; (h) provided dust suppression system in applicable areas;(f) ensure that all equipment, vehicles and other sources of fuels and lubricants will be collected and contained to avoid groundwater contamination; (g) source construction and domestic water requirement from third party, if the available sources will result to water competition with nearby communities.
- y) Contractor shall conduct environment monitoring (ambient air, noise etc) on periodic basis.
- z) The contractor will put in place a grievance management system to address any community grievances/concerns linked to the project and construction activities. This will be documented on the site.

1.5 Accident/Incident Reporting for SHE: The contractor shall inform the Authority in writing, immediately and no later than 24 (twenty four) hours of an incident (including any major environmental hazards) or accident occurring (including, without limitation, any fatality, lost time incident, medical treatment case, first aid case etc) in anyway connected with the Work. The contractor shall also maintain and submit a monthly report of all such incidents/accidents. In addition to this, the contractor shall promptly conduct incident investigations on all fatalities and major accidents/incidents and submit a report with findings/recommendations and actions taken/planned within 15 days from the date of occurrence of the accident/incident. The authority shall be entitled to join the contractor in its investigation or carry out its own.

1.41.6 Labour Laws:

- During continuation of the contract, the Contractor and his sub- contractors shall abide at all times by all existing labour enactments and rules made there under, regulations, notifications and byelaws of State /Central Government or local authorities and any other labour law (including rules), regulations, bye-laws that may passed or notified under any labour law by the state / central government or the local authorities during execution of the Work. The Contractor shall keep the company indemnified in case any action is taken against the Authority by the competent authority on account of contravention of any of the provisions of any act or rules made under these regulations or notifications including amendments;
- In case the Authority is caused to pay or reimburse such amounts as may be necessary to cause or observe or for non-observance of the provisions stipulated in the notifications/bye-laws/acts/rules/regulations including amendments, if any, on the part of the Contractor, the Authority shall also have right to recover from the Contractor any sum required or estimated to be required for making good the loss or damage suffered by the Authority;
- The Contractor shall carry out its activities consistent with the intent of ensuring legally permissible equal opportunity, fair treatment and non-discrimination in relation to recruitment and hiring, compensation, working conditions and terms of employment for its workers (including prohibiting any form of discrimination against women during hiring and providing equal work for equal pay for men and women) and minimizing potential labor retrenchment;
- The Contractor shall not restrict its workers from developing a legally permissible means of expressing their grievances and protecting their rights regarding working conditions and terms of employment.
- The Contractor shall engage contractors and other providers of goods and services a) who do not employ child labour, defined as employment of children whose age is below the statutory minimum age of employment; and b) who do not employ forced labour defined as all work or services not voluntarily performed, that is, extracted from individuals under threat of force or penalty; c) who have appropriate management systems that will allow them to operate in a manner which is consistent with the intent of (a) ensuring legally permissible equal opportunity and fair treatment and non-discrimination for their workers, and (b) not restricting their workers from developing a legally permissible means of expressing their grievances and protecting their rights regarding working conditions and terms of employment.

1.7 Labour Camps:

1. Labour camp should be adequately fenced and isolated from a construction area and should be liveable (sufficient space, lighting, toilets, electricity, cooking area etc)
2. Sufficient supply of drinking water should be maintained at a labour camp.
3. In case of construction sites where 100 or more workers are likely to work for 6 months then an adequate canteen consisting of at least a dining hall, kitchen, store room, pantry and washing places separately for workers and utensils should be maintained.
4. To avoid spread of infections and diseases, proliferation of mosquitoes, flies, rodents and other pests, wastewater generated from domestic activities such as bathing, and washing should not be allowed to flow in open and should be channelized to the nearest municipality drain. In absence of municipality drain, a septic tank and a soak pit system of adequate capacity should be constructed.
5. Containers for collection of food waste, kitchen waste should be provided in labour camp. These containers should be emptied on regular basis.

Note: Also refer section 8A General Information and work requirement section for further details on safety and security details

1.8 Penalty Clause

SN	Item	Penalty
1	Violation of any of the SHE condition(s) and social obligations of the contractor given under the heading Safety, Health, Environment (SHE) and Social Obligations of the Contractor	Rs.5,000/- for single violation, compounded to a maximum of Rs.25,000/- at any single instance
2	Fatal Accident at the work site of the contractor due to negligence of contractor or its personnel.	Rs.5,00,000/- for first fatality & Rs.10,00,000/- for subsequent fatality.
3	Grievous Injury Accident at the work site of the contractor due to negligence of contractor or its personnel	Rs.1,00,000/- for first grievously injured person and Rs.2,00,000/- for every subsequent grievously injured person

SUMMARY OF Detailed estimate		
Name of the work-Signaling Out door and indoor works with Distributed Electronic interlocking (EI) at Yesvantpur Jn. in connection with doubling of Yesvantpur-Channasandra section of Bangalore Division.		
Sl. No.	Description	Estimated value in Rs
1	Schedule - A (SOR)	1,59,11,184.00
2	Schedule - B(Supply)	59,41,386.00
3	Schedule - C (Execution)	1,21,65,012.00
4	Schedule - D (Supply & Execution)	94,47,311.00
5	Schedule - E (Electronic interlocking)	8,39,60,508.00
6	Schedule - F (Fire Alarm)	62,36,863.00
7	Schedule - H (Axle Counter)	8,23,83,960.00
8	Schedule - J (Cable)	3,68,97,260.00
9	Schedule - K (LEDs)	36,77,562.00
10	Schedule - L (Misc.,)	40,30,189.00
11	Schedule - M (Point Machine)	29,33,449.00
12	Schedule - N (Relays)	42,40,135.00
Total - Schedules value in Rupees		26,78,24,819.00

Name of the work -Signaling Out door and indoor works with Distributed Electronic interlocking (EI) at Yesvantpur Jn. in connection with doubling of Yesvantpur-Channasandra section of Bangalore Division.							
SCHEDULE-A (SOR items)							
Sl. No.	SOR NO.	Description	Unit	Rate in Rs.	Quantity	Amount in Rs.	Inspection By
1	(10)101	Excavation of cable trench in all kinds of soil except hard rocky areas including clearing of roots of trees, rocks, bushes etc. to a depth of 1.0 Mtrs and to a width of 0.3 Mtrs. Laying of cables is not included in this schedule.	Mtr.	61.68	6000	370080.00	
2	(10)102	Excavation of cable trench in all kinds of soil except hard rocky areas including clearing of roots of trees, rocks, bushes etc. to a depth of 1.0 Mtrs and to a width of 0.5 Mtrs. Laying of cables is not included in this schedule.	Mtr.	76.50	3000	229500.00	
3	(10)105	Excavation of trench along route of existing cable duct, opening the slabs to accommodate additional cable laying, repositioning the slabs removed after the cables are laid and plastering with cement mortar, and refilling the trench by ramming and consolidating it as per the instructions of K-RIDE Representatives at site.(Laying of cables is not included in this schedule) [Cement, river sand and all other miscellaneous materials required for the work shall be supplied by the Contractor]	Mtr.	207.73	50	10387.00	
4	(10)106	Excavation of trench to a depth of 1 Mtr. for track crossing of cable, laying of DWC/RCC/PVC pipe with collar/coupling, refilling of trench by ramming and consolidating it as per instructions of K-RIDE representative at site. During excavation of trench it has to be ensured that the excavated soil does not mix with the ballast available. The depth of 1m trench shall be from the bottom of sleepers for track crossing. Laying of cables is not included in this schedule. (Supply of DWC/RCC/PVC pipe with couplers/collars is not included in this schedule)	Mtr.	370.86	240	89006.00	
5	(10)107	Excavation of trench to a depth of 1 Mtr. for road crossing of cables, laying of DWC/ RCC/PVC pipes with collar/ coupling, refilling of trench by ramming and consolidating it and resurfacing it to the original position. Laying of cables is not included in this schedule. (Supply of DWC/RCC/PVC pipes with couplers/ collars is not included in this schedule)	Mtr.	482.08	108	52065.00	
6	(10)108	Provision of GI pipes (50/100mm dia) for cable laying with offset at both ends and with couplings over RCC Bridges/ Drainage/ Culverts with concrete masonry supports of size 300mm x 300 mm x 300 mm at an interval of 2Mtrs. The ends of the pipes shall be closed with brick masonry abutments work so that no cable is exposed, The work shall be carried out as per the instructions of K-RIDE representative at site. (Supply of GI pipes with couplings and laying of cables is not included in this schedule) [Stone jelly of size 20/25mm, bricks, sand, cement and all other miscellaneous materials required for the work shall be supplied by the Contractor]	Mtr.	323.87	60	19432.00	

7	(10)109	Provision of GI pipes-(50/100mm dia) for cable laying with offset at both ends and with couplings over girder bridges by fixing on suitable MS Clamps at an interval of 2 Mtrs. The ends of the pipes shall be closed with brick masonry abutments work so that no cable is exposed, The work shall be carried out as per the instructions of Railway/K-RIDE representative at site. (Supply of GI pipes with couplings and laying of cables is not included in this schedule). [MS angles, flats, bolts and nuts for manufacturing fixing clamps, bricks, river sand , cement and all other miscellaneous required for the work shall be supplied by the Contractor]	Mtr.	383.15	60	22989.00	
8	10(110)	Provision of GI pipes (50/100mm dia) for cable laying in hard rocky area with off sets at both ends duly supported by concrete blocks of size 300mm x 300 mm x 300 mm at an interval of 2m. The ends of the pipes shall be closed with brick masonry abutments work so that no cable is exposed, The work shall be carriedout as per the instructions of K-RIDE representative at site. (Supply of GI pipe with couplings and laying of cables are not included in this schedule) [Stone jelly of size 20/25mm, bricks, sand, cement and all other miscellaneous materials required for the work shall be supplied by the contractor]	Mtr.	299.18	150	44877.00	
9	(10)111	Laying of signaling/power/ telecommunication cables as per cable plan in cable trenches, masonry ducts, RCC Pipes, DWC pipes, GI Pipes etc. (Supply of cables are not included in this schedule)	Mtr.	17.50	100000	1750000.00	
10	(10)115	Refilling of cable trench 1 Mtr. depth by 0.3 Mtr. width throughout, with earth after laying of cables, and consolidating the trench by ramming and leveling.	Mtr.	14.83	6000	88980.00	
11	(10)116	Refilling of cable trench 1Mtr. depth by 0.5 Mtr. width throughout, with earth after laying of cables, and consolidating the trench by ramming and leveling.	Mtr.	18.57	3000	55710.00	
12	(10)118	Supply of RCC cable markers as per drawing No.CSTE/CN/OFC/1. The lettering on the cable marker shall be "SIG" / "TELE" / "OFC" as per the instructions of Railway/K-RIDE representative at site.	No.	296.00	600	177600.00	Consignee
13	(10)119	Digging of pit to a depth of 800mm of size 300mm X 300mm, casting of concrete foundation of size 300mm X 300mm X 300mm and Placing of RCC cable markers on top of the foundation and refilling the pit and consolidating it by ramming. The cable markers shall be provided at an interval of 0 Mtrs. within station limits and 50 Mtrs. outside station limits throughout the cable route, diversions and also at every track/road crossing.	No.	216.15	600	129690.00	
14	(10)120	Excavation of cable coil pit to a size of 1.5Mtr x 1.5Mtr and depth as instructed by K-RIDE representative at site, for coiling the cables in rear of relay rooms/ AFTC huts, apparatus cases etc. The work includes coiling the underground cables, and placing closely one layer of country bricks of size approx. 220mm x 100mm x 60mm breadth wise above the cables to cover all the cables in the cable pit, closing and consolidating the pit by ramming and leveling. [Country bricks of size 220mm x 100mm x 60mm (approximately) shall be supplied by the Contractor]	Cu.Mtr.	913.14	40	36526.00	
15	(10)121	Supply of double walled corrugated pipe 103.5mm inner dia & 120mm outer dia conforming to specification no. IS14930 (Part 2): 2001 with one coupler for every 6 Mtr of pipe as specified in Vol.II of the Tender document.	Mtr.	468.5	348	163038.00	BITES
16	(10)122	Supply of GI pipes - 50mm dia-3.65mm thick as specified in Vol.II of the Tender document.	Mtr.	610.90	120	73308.00	BITES
17	(10)123	Supply of GI pipes - 100mm dia-4.5mm thick as specified in Vol.II of the Tender document	Mtr.	1493.06	150	223959.00	BITES

18	(10)201	Excavation of pit, casting concrete foundation and erection of apparatus case full size as per Drg. No.SG/CN/02/6 and fixing of 2 Nos. of 'E' type locks, one for the front door and another for the back door, fixing of one hard wood shelf plank 37mm thick and painting the apparatus case inside and outside with one coat of red-oxide and two coats of aluminium paints. (Supply of apparatus case is not included in this schedule) [Foundation bolts & nuts, 'E' type locks, cement, river sand, stone jelly of size 20/25 mm, hardwood plank of 37mm thick, paints, varnish, fixing bolts & nuts and all other miscellaneous materials required for the work shall be supplied by the Contractor.]	No.	17578.03	40	703121.00	
19	(10)202	Excavation of pit, casting concrete foundation and erection of apparatus case half size as per Drg, No.SG/CN/02/7, fixing one 'E' type lock for the front door and latching arrangement for the back door, and fixing of one hardwood shelf plank 37mm thick and painting the apparatus case inside and outside with one coat of red-oxide and two coats of aluminium paints. (Supply of apparatus case is not included in this schedule) [Foundation bolts and nuts, cement, 'E' type locks, river sand, stone jelly of size 20/25mm, 37mm hard wood planks, latching arrangements, paints, varnish, fixing bolts & nuts and all other miscellaneous materials required for the work shall be supplied by the Contractor]	No.	12400.55	60	744033.00	
20	(10)208a	Excavation of pit in and around the existing location boxes very carefully without damaging the working cables and shifting and turning the location boxes to clear of the infringement as instructed by the K-RIDE representative at site. The work includes ensuring the safety of the signaling system, releasing the cable coils to give access for shifting/turning the location boxes. Necessary masonry work and earth work in and around the location boxes to the required level shall be done as instructed by the K-RIDE representative at site. If the existing earth connections to the location boxes are disturbed, the earth wires shall be properly re-connected. [All materials required for the work shall be supplied by the Contractor] (a) Shifting of Apparatus case (full)	No.	5153.10	10	51531.00	
21	(10)208b	Excavation of pit in and around the existing location boxes very carefully without damaging the working cables and shifting and turning the location boxes to clear of the infringement as instructed by the K-RIDE representative at site. The work includes ensuring the safety of the signaling system, releasing the cable coils to give access for shifting/turning the location boxes. Necessary masonry work and earth work in and around the location boxes to the required level shall be done as instructed by the K-RIDE representative at site. If the existing earth connections to the location boxes are disturbed, the earth wires shall be properly re-connected. [All materials required for the work shall be supplied by the Contractor]. (b) Shifting of Apparatus case (half)	No.	3410.93	10	34109.00	

22	(10)209	<p>Termination of new main/tail cables on the existing terminals/ fuse blocks in apparatus cases/ battery boxes/ CT boxes/ cable termination racks as per approved circuit diagram. The terminal particulars are to be repainted /corrected on the doors of apparatus cases/ battery boxes/ cable termination boxes and FTOT index board as instructed by Railway/K-RIDE representative at site. This work includes closing the opening created for entry of new cables in the apparatus cases with masonry brick work and sealing the bottom of the apparatus cases/ cable termination racks with cable compound.</p> <p>[Paints, wire PVC 3/0.75mm and 16/0.2mm copper, sealing compound, bricks, cement, river sand and all other required miscellaneous materials shall be supplied by the contractor].</p>	Terminal	70.81	300	21243.00	
23	(10)210b	<p>Termination of main, tail, Signaling and power cables and internal wiring on terminal/ fuse blocks in new apparatus cases, cable termination boxes and in gate Lodges excluding cable termination rack at relay room. The work includes fixing of all new cables by teakwood clamp on teakwood base plank, fixing of Phynolic synthetic industrial fibre base fine weave cotton fibre board 6mm thick for terminal board to suit each apparatus case, varnishing all teakwood items, fixing of terminals/ fuse blocks on the terminal board, drilling of necessary holes, termination of cables, wiring, identification of cables using aluminium tags with letters punched neatly, as per approved circuit diagram and cable plan, painting of particulars on sleeves and also on the inner side of the doors of apparatus cases. After terminations are over, the side openings of apparatus case foundation shall be closed with brick work, cement plastered, the inter-space filled with river sand up to base level and the bottom surface shall be sealed with sealing compound. (Supply of PBT terminals and Fuse blocks is not covered in this schedule) [Cement, teakwood cable clamp 50mm x 50mm, base planks 100mm x 25mm, Phynolic synthetic industrial fibre base fine weave cotton fibre sheet - 6mm thick to IS specification 2036 - 1995 - Type F5, PVC/Nylon sleeves, varnish, paints, bolts, nuts and washers, Non- deteriorating type of fuses of various capacities, Aluminium cable tags, sealing compound, country bricks 220mm x 100mm x 60mm, copper bus bars, brass screw, river sand, wire PVC3/0.75mm copper and other miscellaneous materials shall be supplied by the Contractor].</p> <p>Termination of main, tail, Signaling and power cables and internal wiring on terminal/ fuse blocks in new apparatus cases, cable termination boxes and in gate Lodges excluding cable termination rack at relay room. The work includes fixing of all new cables by teakwood clamp on teakwood base plank, fixing of Phynolic synthetic industrial fibre base fine weave cotton fibre board 6mm thick for terminal board to suit each apparatus case, varnishing all teakwood items, fixing of terminals/ fuse blocks on the terminal board, drilling of necessary holes, termination of cables, wiring, identification of cables using aluminium tags with letters punched neatly, as per approved circuit diagram and cable plan, painting of particulars on sleeves and also on the inner side of the doors of apparatus cases. After terminations are over, the side openings of apparatus case foundation shall be closed with brick work, cement plastered, the inter-space filled with river sand up to base level and the bottom surface shall be sealed with sealing compound.(Supply of PBT terminals and Fuse blocks is not covered in this schedule).</p> <p>[Cement, teakwood cable clamp 50mm x 50mm, base planks 100mm x 25mm, Phynolic synthetic</p>	Fuse block	202.14	7000	1414980.00	

24	(10)211a	<p>Termination of main, tail, Signaling and power cables and internal wiring by fixing additional terminals/ fuse blocks on the existing terminal boards of apparatus cases, cable termination boxes etc. The work includes fixing of all new cables by teakwood clamp on teakwood base plank, varnishing all teakwood items, fixing of terminals/ fuse blocks, on the existing terminal boards, drilling of necessary holes, termination of cables, wiring, identification of cables using aluminium tags with letters punched neatly, as per approved circuit diagram and cable plan, painting of particulars on sleeves and also on the inner side of the doors of apparatus cases. After terminations are over, the side openings of apparatus case foundation shall be closed with brick work, cement plastered, the inter- space filled with river sand up to base level and the bottom surface shall be sealed with sealing compound. (Supply of PBT terminals and Fuse blocks is not covered in this schedule). [Cement, teak wood cable clamp 50mm x 50mm, base planks 100mm x 25mm, PVC/Nylon sleeves, varnish, paints, bolts, nuts and washers, Non-deteriorating type of fuses of various capacities, Aluminium cable tags, sealing compound, country bricks 220mm x 100mm x 60mm, copper bus bars, brass screw, river sand, wire PVC 3/0.75mm copper and other miscellaneous materials shall be supplied by the Contractor].Termination of cables on 25/60mm PBT terminals (existing location)</p>	Termin I	145.39	100	14539.00	
25	(10)211b	<p>Termination of main, tail, Signaling and power cables and internal wiring by fixing additional terminals/ fuse blocks on the existing terminal boards of apparatus cases, cable termination boxes etc. The work includes fixing of all new cables by teakwood clamp on teakwood base plank, varnishing all teakwood items, fixing of terminals/ fuse blocks, on the existing terminal boards, drilling of necessary holes, termination of cables, wiring, identification of cables using aluminium tags with letters punched neatly, as per approved circuit diagram and cable plan, painting of particulars on sleeves and also on the inner side of the doors of apparatus cases. After terminations are over, the side openings of apparatus case foundation shall be closed with brick work, cement plastered, the inter- space filled with river sand up to base level and the bottom surface shall be sealed with sealing compound. (Supply of PBT terminals and Fuse blocks is not covered in this schedule) [Cement, teak wood cable clamp 50mm x 50mm, base planks 100mm x 25mm, PVC/Nylon sleeves, varnish, paints, bolts, nuts and washers, Non-deteriorating type of fuses of various capacities, Aluminium cable tags, sealing compound, country bricks 220mm x 100mm x 60mm, copper bus bars, brass screw, river sand, wire PVC3/0.75mm copper and other miscellaneous materials shall be supplied by the Contractor].Termination of cables on PBT fuse block (existing location)</p>	Fuse block	181.70	20	3634.00	

26	(10)212a	<p>Manufacture and supply of M.S. relay frames of suitable size to hold up to 4/ 8/ 12/ 20 relays /plug in type HMU as required by K-RIDE and fixing them in apparatus cases for all types of signal control circuits, LC gate control circuit and Point control circuits, fixing of plug boards, relays, resistors and electrolytic condensers on Phynolic synthetic industrial fibre base fine weave cotton fibre sheet - 6mm thick to IS specification 2036 - 1995 - Type F5, wiring and termination as per approved circuit diagram and painting the particulars.</p> <p>(Supply of all types of relays, plug boards, connectors, retaining clips and plug in type HMU is not covered in this schedule).</p> <p>[Wire PVC copper, 3/0.75mm and 16/0.2mm copper, Phynolic synthetic industrial fibre base fine weave cotton fibre sheet - 6mm thick to IS specification 2036 - 1995 - Type F5, for fixing resistors and condensers, MS flats 25mm x 6mm brass bolts and nuts, paints, soldering materials, resistors, condensers and all other miscellaneous materials required for the work shall be supplied by the contractor].</p> <p>(a) Wiring of Signal/ point/ LC control circuit (up to 4 relays/Plug in type HMU)</p>	Set	4758.39	26	123718.00
27	(10)212b	<p>Manufacture and supply of M.S. relay frames of suitable size to hold up to 4/ 8/ 12/ 20 relays/plug in type HMU as required by Railway/K-RIDEs and fixing them in apparatus cases for all types of signal control circuits, LC gate control circuit and Point control circuits, fixing of plug boards, relays, resistors and electrolytic condensers on Phynolic synthetic industrial fibre base fine weave cotton fibre sheet - 6mm thick to IS specification 2036 - 1995 - Type F5, wiring and termination as per approved circuit diagram and painting the particulars.</p> <p>(Supply of all types of relays, plug boards, connectors, retaining clips and plug in type HMU is not covered in this schedule).</p> <p>[Wire PVC copper, 3/0.75mm and 16/0.2mm copper, Phynolic synthetic industrial fibre base fine weave cotton fibre sheet - 6mm thick to IS specification 2036 - 1995 - Type F5, for fixing resistors and condensers, MS flats 25mm x 6mm brass bolts and nuts, paints, soldering materials, resistors, condensers and all other miscellaneous materials required for the work shall be supplied by the contractor].</p> <p>(b) Wiring of Signal/ Point/ LC control circuit (up to 8 relays/plug in type HMU)</p>	Set	8436.49	8	67492.00
28	(10)212c	<p>Manufacture and supply of MS. relay frames of suitable size to hold up to 4/ 8/ 12/ 20 relays /plug in type HMU as required by K-RIDE and fixing them in apparatus cases for all types of signal control circuits, LC gate control circuit and Point control circuits, fixing of plug boards, relays, resistors and electrolytic condensers on Phynolic synthetic industrial fibre base fine weave cotton fibre sheet - 6mm thick to IS specification 2036 - 1995 - Type F5, wiring and termination as per approved circuit diagram and painting the particulars.</p> <p>(Supply of all types of relays, plug boards, connectors, retaining clips and plug in type HMU is not covered in this schedule).</p> <p>[Wire PVC copper, 3/0.75mm and 16/0.2mm copper, Phynolic synthetic industrial fibre base fine weave cotton fibre sheet - 6mm thick to IS specification 2036 - 1995 - Type F5, for fixing resistors and condensers, MS flats 25mm x 6mm brass bolts and nuts, paints, soldering materials, resistors, condensers and all other miscellaneous materials required for the work shall be supplied by the contractor].</p> <p>(c) Wiring of Signal/ Point/ LC control circuit (up to 12 relays/plug in type HMU)</p>	Set	10925.37	4	43701.00

29	(10)212d	<p>Manufacture and supply of M.S. relay frames of suitable size to hold up to 4/ 8/ 12/ 20 relays/plug in type HMU as required by Railway/K-RIDE and fixing them in apparatus cases for all types of signal control circuits, LC gate control circuit and Point control circuits, fixing of plug boards, relays, resistors and electrolytic condensers on Phynolic synthetic industrial fibre base fine weave cotton fibre sheet - 6mm thick to IS specification 2036 - 1995 - Type F5, wiring and termination as per approved circuit diagram and painting the particulars.</p> <p>(Supply of all types of relays, plug boards, connectors, retaining clips and plug in type HMU is not covered in this schedule).</p> <p>[Wire PVC copper, 3/0.75mm and 16/0.2mm copper, Phynolic synthetic industrial fibre base fine weave cotton fibre sheet - 6mm thick to IS specification 2036 - 1995 - Type F5, for fixing resistors and condensers, MS flats 25mm x 6mm brass bolts and nuts, paints, soldering materials, resistors, condensers and all other miscellaneous materials required for the work shall be supplied by the contractor].</p> <p>(d) Wiring of Signal/ Point/ LC control circuit (up to 20 relays/Plug in type HMU)</p>	Set	13082.91	4	52332.00	
30	(10)213a	<p>Painting of existing apparatus cases without disturbing the terminations and equipments inside. The work involves scraping of old paint, applying one coat of Red oxide and two coats of Aluminium paint on the inside and outside the apparatus cases, and painting of termination and equipment particulars on the doors of the apparatus cases, as instructed by K-RIDE representative at site.[Aluminium paint, red-oxide and all other miscellaneous materials required for the work shall be supplied by the Contractor].</p> <p>(a) Painting of existing Apparatus case - Full size</p>	No.	2276.18	10	22762.00	
31	(10)213b	<p>Painting of existing apparatus cases without disturbing the terminations and equipments inside. The work involves scraping of old paint, applying one coat of Red oxide and two coats of Aluminium paint on the inside and outside the apparatus cases, and painting of termination and equipment particulars on the doors of the apparatus cases, as instructed by Railway/K-RIDE representative at site. [Aluminium paint, red-oxide and all other miscellaneous materials required for the work shall be supplied by the Contractor].</p> <p>(b) Painting of existing Apparatus Case - Half size.</p>	No.	2177.39	10	21774.00	
32	(10)214	<p>Fixing and wiring of platform repeaters. The work involves fixing of platform repeater using suitable fixing arrangements at places indicated, wiring the same and painting as per the instructions of Railway representative at site. The signal shall be connected to the apparatus case using cables neatly clamped. The work also includes provision of one EWS lock. (Laying of cable is not included in the scope of this work.) (Supply of repeater signals and cables is not included in this schedule).</p> <p>[Wire PVC 3/0.75mm copper, paint, EWS lock and all other miscellaneous materials required for the work shall be supplied by the Contractor].</p>	Nos.	6563.39	2	13127.00	
33	(10)215	<p>Painting of existing colour light Signals as per standard practice. The work involves scraping of old paint, applying one coat of Red oxide and two coats of Aluminium/ enamel paint on the Signals - complete as instructed by Railway/K-RIDE representative at site.</p> <p>[Aluminium paint, red-oxide and all other miscellaneous materials required for the work shall be supplied by the Contractor].</p>	No.	2349.60	10	23496.00	

34	(10)216a	Alterations to painted termination/wiring particulars of functions in the existing apparatus cases, cable termination boxes etc., on the PVC/nylon sleeves and painting of new nomenclature on the existing signaling gadgets. This work includes carrying out alterations of particulars on the inner side of the doors of apparatus cases, re-numbering of apparatus cases and cable termination boxes. [Paints and all other miscellaneous materials required for the work shall be supplied by the Contractor]. (a)Alteration to painting particulars (Apparatus Case - Full size)	No.	1575.03	10	15750.00	
35	(10)216b	Alterations to painted termination/wiring particulars of functions in the existing apparatus cases, cable termination boxes, etc., on the PVC/nylon sleeves and painting of new nomenclature on the existing signaling gadgets. This work includes carrying out alterations of particulars on the inner side of the doors of apparatus cases, re-numbering of apparatus cases and cable termination boxes. [Paints and all other miscellaneous materials required for the work shall be supplied by the Contractor]. (b) Alteration to painting particulars (Apparatus case - half size)	No.	826.10	10	8261.00	
36	(10)218	Excavation of pit, casting concrete foundation as per Drg.No.SG/CN/02/9 using metallic templates, for erection of colour light signals up to 4 aspects. [Foundation bolts, cement, river sand, stone jelly of size 20/25mm dia and all other miscellaneous materials required for the work shall be supplied by the Contractor].	No.	8914.60	24	213950.00	
37	(10)219	Erection of surface base, signal pole, mounting of colour light signal up to 4 aspects complete on Signal pole/ Off-set bracket, (for LED/ filament bulbs) with lenses, triple pole lamp holder, filament switching units, CLS transformer, current regulators (whichever is applicable), fixing of ladder with platform complete and concreting of ladder shoe, fixing of number plates, marker board, lens guard, fixing of speed limit board wherever necessary, termination of tail cables, wiring of signal unit with PVC wire 3/0.75mm copper, provision of EWS locks, and painting of one coat of red oxide and two coats of aluminium/ enamel paints. When the aspect is fixed on offset bracket using 'U' bolts and nuts, a through bolt shall be provided by drilling a hole in the signal pole to prevent the offset bracket from sliding down. (Supply of surface base, offset bracket, CLS pole, CLS aspects complete, ladder with shoes and platform, Speed limit board, LED aspects, current regulators, lamp holders, lamps, filament switching unit and CLS transformer is not covered in this schedule). ['U' bolts and nuts, through bolts and nuts, cement, stone jelly 20/25mm dia, river sand, Signal Collar Rings, wire PVC 3/0.75mm copper, lens-guard, all fixing bolts and nuts, lead wool, paints PVC/Nylon sleeves, enameled number plates, enameled marker boards, EWS locks, and all other miscellaneous materials for the work shall be supplied by the Contractor].	No.	9792.14	24	235011.00	
38	(10)220	Excavation of pit and casting concrete foundation as per Drg, No.SG/CN/02/10 using metallic templates, for erection of ground type colour light shunt signal. [Foundation bolts and nuts, cement, river sand, stone jelly of size 20/25mm and all other miscellaneous materials for the work shall be supplied by the Contractor].	No.	4483.02	24	107592.00	

39	(10)221	Erection of Ground type shunt signal complete including surface base, signal pole, LED aspects/ lenses, bulbs with holders (whichever is applicable), fixing of lens guards, number plate, termination of tail cables, wiring of signal unit with PVC wire 3/0.75mm copper, provision of EWS locks and painting of one coat of red oxide and two coats of Aluminium/ enamel paint. (Supply of Ground type shunt signal complete including surface base, signal pole, LED aspects, holder, bulbs, and lenses is not covered in this schedule). [Wire PVC 3/0.75mm copper, lens guards, EWS locks, Enameled number plates, bolts and nuts, lead wool, paints and all other miscellaneous materials shall be supplied by the Contractor].	No.	3732.66	24	89584.00	
40	(10)222	Fixing of Offset brackets using 'U' bolts and nuts, erection of Post type shunt Signals, termination of tail cables and wiring using wire PVC 3/0.75mm copper, provision of EWS lock and painting of one coat of red- oxide and two coats of aluminium/ enameled paint. The work also includes drilling suitable holes on the CLS post and provision of a through bolt with nut to prevent the Off-set bracket from slipping down. (Supply of Post type Shunt Signals, LED aspects and Off set brackets is not covered in this schedule). ['U' bolts and nuts, through bolts with nut, wire PVC3/0.75mm copper, EWS lock, Enameled number plates, wire mesh, PVC/Nylon sleeves, paints and all other miscellaneous materials shall be supplied by the contractor].	No.	2871.59	24	68918.00	
41	10_223	Fixing Multi lamp/ Stencil type route indicators - complete, termination of tail cables, wiring as per approved circuit diagram using wire PVC 3/0.75mm & 16/0.2mm copper, provision of EWS - required Nos., and painting. (Supply of route indicators is not covered in this schedule) [Fixing bolts and nuts, EWS locks wires PVC 3/0.75mm & 16/0.2mm copper, wire mesh, PVC/Nylon sleeves, paints and all other miscellaneous materials shall be supplied by the Contractor].					
		a. Fixing and wiring of Multi lamp route indicator	Nos.	4918.14	5	24591.00	4918.14
42	(10)224a	Fixing of junction type route indicators - 1 way to 6 ways - complete/ fixing of additional limb to the existing route indicators, termination of tail cables, wiring as per approved circuits diagram using wire PVC 3/0.75mm copper, provision of required No of EWS locks, wire mesh, and painting. (Supply of junction type Route Indicators - complete and additional limb is not covered in this schedule). [3/0.75mm wire PVC, fixing bolts and nuts, EWS locks, wire mesh, PVC/Nylon sleeves, paints and all other miscellaneous materials shall be supplied by the Contractor]. (a)Fixing and wiring of direction type route indicator - 1 way	Nos.	2740.76	3	8222.00	
43	(10)224b	Fixing of junction type route indicators - 1 way to 6 ways - complete/ fixing of additional limb to the existing route indicators, termination of tail cables, wiring as per approved circuits diagram using wire PVC 3/0.75mm copper, provision of required No of EWS locks, wire mesh, and painting. (Supply of junction type Route Indicators - complete and additional limb is not covered in this schedule).[3/0.75mm wire PVC, fixing bolts and nuts, EWS locks, wire mesh, PVC/Nylon sleeves, paints and all other miscellaneous materials shall be supplied by the Contractor]. (b) Fixing and wiring of direction type route indicator - 2 way	Nos.	3276.42	10	32764.00	

44	(10)224c	Fixing of junction type route indicators - 1 way to 6 ways - complete/ fixing of additional limb to the existing route indicators, termination of tail cables, wiring as per approved circuits diagram using wire PVC 3/0.75mm copper, provision of required No of EWS locks, wire mesh, and painting. (Supply of junction type Route Indicators - complete and additional limb is not covered in this schedule). [3/0.75mm wire PVC, fixing bolts and nuts, EWS locks, wire mesh, PVC/Nylon sleeves, paints and all other miscellaneous materials shall be supplied by the Contractor]. (c) Fixing and wiring of direction type route indicator - 3 way	No.	3752.69	4	15011.00	
45	(10)225	Fixing of offset brackets using 'U' bolts and nuts, erection of Calling On Signals/ 'A' marker lights, termination of tail cables and wiring using wire PVC 3/0.75mm copper, provision of EWS lock, number plates/ marker boards and painting. The work also includes drilling suitable holes on the CLS post and provision of a through bolt with nut to prevent the Off- set bracket from slipping down. (Supply of Calling On Signal/ 'A' marker light, LED aspects/holders & bulbs and Off set brackets is not covered in this schedule). ['U' bolts and nuts, through bolts with nut, wire PVC 3/0.75mm copper, EWS lock, Enameled number plates, wire mesh, PVC/Nylon sleeves, paints and all other miscellaneous materials shall be supplied by the contractor].	No.	2540.51	24	60972.00	
46	10_226	Releasing of existing tail cables and drawal of new tail cables for colour light signals up to four aspects with or without route indicator, post type shunt signal and Calling on signals, termination of new tail cables and wiring using wire PVC 3/0.75mm copper. This work includes drawal of new tail cables into the signal post duly releasing the existing tail cables from the relevant signals and re-surfacing the earth excavated as instructed by Railway representative at site.[Wire PVC 3/0.75mm copper, paints and all other miscellaneous materials shall be supplied by the Contractor].	Per Cable	1467.165	50	73358.00	
47	10_228	Removal of existing CLS units, fixing of new CLS units with LED aspects/ lamps, holders etc., up to four aspects, directly or using off set brackets duly drilling holes on the signal poles, provision of EWS locks wherever necessary, termination of tail cables and wiring using wire PVC3/0.75mm copper and painting of aspect. The new tail cables shall be taken through the signal poles and the unwanted cables duly released. (Supply of CLS unit with LED aspects/ lamps holders, CLS transformers is not included in this schedule.) [EWS locks, Wire PVC 3/0.75mm copper lenses guard, wire netting arrangements, paints and all other miscellaneous materials shall be supplied by the Contractor].	Nos.	10678.665	12	128144.00	
48	(10)229	Manufacture and supply of enameled number plates as per drawing No.TY/08/2008 with fixing arrangements and fixing them on the existing Signals as per the instructions of Railway/K-RIDE representative at site. [Enameled number plates with fixing arrangements with bolts and nuts shall be supplied by the Contractor]	No.	603.42	20	12068.00	Consignee
49	10_230	Supply and provision of Screening arrangement for Signals in RE area as per standard practice. The work comprises of providing MS angle frame and wire mesh in order to avoid close proximity of OHE wires. The work also includes provision of earthing wire using 4 SWG GI wires from the screening arrangement up to surface base as per the instructions of K-RIDE representative at site. [All materials required for this work shall be supplied by the Contractor]	No.	1809.548	4	7238.00	

50	(10)234	Provision of earth electrodes as per drawing No.SG/SN/02/13 and earthing of metallic sheath and armour of all cables in all apparatus cases, relay room, equipment room, SM's room for block and control, and earthing of all equipments in apparatus cases, power room, relay rack, cable termination rack, control panel, signals, lever frames with MS flat 35mm X 6mm/19C cable (MS flat for closer by areas and MS flat/19c cable combination for farther areas) as per the instructions of K-RIDE representative at site. The work includes painting of earth resistance value on the earth pit. (Supply of 19C cable is not covered in the scope of this schedule) [MS flat for earthing 35mm X 6mm, cement, GI earth electrodes, common salt, charcoal, country bricks, river sand, soldering materials and all other miscellaneous materials required for the work shall be supplied by the Contractor]	No.	3202.22	60	192133.00	BITES
51	(10)236	Installation of combined type point machine - IRS type and connecting all ground connections including wiring and termination in point machine and interconnections between point machine and CT box through PVC hose pipe with 3/0.75mm and 7/1.40mm copper wire and painting. This work includes provision of insulation to stretcher bars, throw bar lug and "D" bracket wherever required, cutting of notches on the point machines covers to suit crank handle configuration. (Combined type point machine with ground connection, uninsulated stretcher bar, throw bar lug and 'D' brackets will be supplied by K-RIDE. [All types of insulations connected to point work, coal bengal, all type of bolts and nuts, washers spring/flat wire PVC 7/1.4mm copper, PVC hose pipe, paints, PVC/nylon sleeves and all other miscellaneous materials required for the work shall be supplied sby the Contractor]. (Rails of different lengths will be supplied by K-RIDE. The Contractor has to cut the rails to the required lengths as per the requirement). [GI pipes 25mm thick, barbed steel wire, MS angles 50mm x 50mm x 5mm and MS flats 50mm x 5mm for fabrication of gate, and all other miscellaneous materials required for the work shall be supplied by the Contractor]	No.	15763.95	20	315279.00	
52	(10)238a	Supply of Colour Light Signal pole 140mm dia, 4.6Mtr/ 3.6Mtr tall with necessary inspection as per specification/ drawing/ description enclosed in this document. (a) Supply of Colour Light Signal pole (4.6Mtr)	No.	5906.04	10	59060.00	BITES
53	(10)238b	Supply of Colour Light Signal pole 140mm dia, 4.6 Mtr/ 3.6 Mtr tall with necessary inspection as per specification/ drawing/ description enclosed in this document. (b) Supply of Colour Light Signal pole (3.6 Mtr)	No.	5293.72	14	74112.00	BITES
54	(10)239	Supply of surface base to suit CLS Signal pole 140mm dia with necessary inspection as per specification/ drawing/ description enclosed in this document.	No.	7330.04	24	175921.00	BITES
55	(10)240a	Supply of ladder with platform and shoes to suit CLS pole 4.6 Mtr/ 3.6 Mtr tall, with necessary inspection as per specification/ drawing/ description enclosed in this document. (a) Supply of ladder with platform and shoes for 4.6 Mtr CLS pole	No.	5701.34	10	57013.00	BITES
56	(10)240b	Supply of ladder with platform and shoes to suit CLS pole 4.6 Mtr/ 3.6 Mtr tall, with necessary inspection as per specification/ drawing/ description enclosed in this document. (b) Supply of ladder with platform and shoes for 3.6 Mtr CLS pole	No.	5498.42	14	76978.00	BITES
57	(10)241	Supply of post type shunt signal - complete with hood etc., with necessary inspection as per specification/ drawing/ description enclosed in this document.	No.	5090.80	24	122179.00	BITES

58	(10)242	Supply of ground type shunt signal - complete with surface base, signal pole, hood etc., with necessary inspection as per specification/ drawing/ description enclosed in this document.	No.	7330.04	24	175921.00	BITES
59	(10)243b	Supply of Colour Light Signal Multi Unit type - complete for 4/ 3/ 2 aspect with mounting socket, with necessary inspection as per specification/ drawing/ description enclosed in this document. (b) Supply of Colour Light Signal unit - 3 aspect	No.	18326.88	10	183269.00	BITES
60	(10)243c	Supply of Colour Light Signal Multi Unit type - complete for 4/ 3/ 2 aspect with mounting socket, with necessary inspection as per specification/ drawing/ description enclosed in this document. (c) Supply of Colour Light Signal unit - 2 aspect	No.	15272.40	14	213814.00	BITES
61	(10)244a	Supply of Junction type route indicator - 5 unit arm - 1/ 2/ 3/ 4/ 5/ 6 way with mounting sockets, with necessary inspection as per specification/ drawing/ description enclosed in this document. (a) Supply of Junction type route indicator - 1 way	No.	19345.04	3	58035.00	BITES
62	(10)244b	Supply of Junction type route indicator - 5 unit arm - 1/ 2/ 3/ 4/ 5/ 6 way with mounting sockets, with necessary inspection as per specification/ drawing/ description enclosed in this document. (b) Supply of Junction type route indicator - 2 way	No.	25454.00	10	254540.00	BITES
63	(10)244c	Supply of Junction type route indicator - 5 unit arm - 1/ 2/ 3/ 4/ 5/ 6 way with mounting sockets, with necessary inspection as per specification/ drawing/ description enclosed in this document. (c) Supply of Junction type route indicator - 3 way	No.	31562.96	4	126252.00	BITES
64	(10)245a	Supply of Calling On Signal / 'A' marker light - complete with necessary inspection as per specification/ drawing/ description enclosed in this document. (a) Supply of Calling On Signal	No.	3665.02	24	87960.00	BITES
65	(10)246a	Supply of off-set brackets - large/ small made of cast iron with necessary inspection as per specification/ drawing/ description enclosed in this document. (a) Supply of off-set bracket (large)	No.	3665.02	24	87960.00	BITES
66	(10)246b	Supply of off-set brackets - large/ small made of cast iron with necessary inspection as per specification/ drawing/ description enclosed in this document. (b) Supply of off-set bracket (small)	No.	2646.86	24	63525.00	BITES
67	(10)249a	Supply of PBT terminals 25mm/ 60mm centre and PBT Fuse blocks with necessary inspection as per specification/ drawing/ description enclosed in this document. (a) Supply of PBT terminal - 25mm centre	No.	78.32	7000	548240.00	RDSO
68	(10)249b	Supply of PBT terminals 25mm/ 60mm centre and PBT Fuse blocks with necessary inspection as per specification/ drawing/ description enclosed in this document. (b) Supply of PBT terminal - 60mm centre	No.	106.80	1000	106800.00	RDSO
69	(10)251a	Supply of Apparatus case (full/ half/ quarter size) to suit South western Railway standard with necessary inspection as per specification/ drawing/ description enclosed in this document: (a) Supply of Apparatus case - full size.	No.	21381.36	40	855254.00	BITES

70	(10)251b	Supply of Apparatus Cases (full/ half/ quarter size) to suit South western Railway standard with necessary inspection as per specification/ drawing/ description enclosed in this document: (b) Supply of Apparatus case - half size.	No.	15272.40	60	916344.00	BITES
71	(10)253	Supply of lamp proving relays for LED aspects with plug boards, connectors and retaining clips with necessary inspection as per RDSO specification/ drawing/description enclosed in this document.	No.	6391.98	225	1438196.00	RDSO
72	(10)254	Supply of QBCA1 - heavy duty contact relays with necessary inspection as per RDSO specification/ drawing/ description enclosed in this document.	No.	7369.20	50	368460.00	RDSO
73	(10)257	Supply of Electric Key Transmitter - rotary type of required ward Nos. with keys, with necessary inspection as per specification/ drawing/ description enclosed in this document.	No .	7616.62	4	30466.00	RDSO
74	(10)306	Carrying out alterations to the existing relays in the relay racks/apparatus cases as per the approved circuit diagram using wire PVC 16/0.2mm copper. The work includes painting alterations and releasing the unwanted wires carefully without disturbing the existing wiring. [Wire PVC 16/0.2mm copper, soldering materials, bunching threads, condensers, resistances and teakwood plank for fixing them and all other miscellaneous materials required for the work shall be supplied by the Contractor].	Relay	669.35	50	33468.00	
75	(10)326	Installation of single line FM type tokenless block instruments on the block counter. The work involves termination of cables on the test panel and block counter, block wiring, interconnection between test panels and block instrument by underground signaling cable and painting the instrument as per the instructions of Railway representative at site. (Supply of block instruments, block counters and underground cables is not covered in this schedule). fixing terminals, wire PVC 16/0.2mm copper, 3/0.75mm, paint, and all other miscellaneous materials required for the work shall be supplied by the contractor].	No.	16148.16	2	32296.00	
76	10(335)	Supply and installation of 4 wire DTMF based way station equipment complete as per RDSO specification No.IRS.TC-60/93 and 4 wire control telephone with audio visual indication and reset button fitted on telephone conforming to specification	No.	14622.70	2	29245.00	
77	(10)336	Supply and provision of Rubber mat of not less than 6mm thick and with an insulation to withstand 650VAC, on the floor of relay room etc at places as indicated by K-RIDE representative at site.	Sq.feet	139.37	320	44598.00	
78	(10)412	Supply and installation of teakwood glass fronted box of size 300mm x 600mm x 75mm with hooks to keep various keys with description engraved on the tags. [TW Glass fronted box of size 300mm x 600mm x 75mm with built in lock, hooks, engraved tags and all other miscellaneous materials required for the work shall be supplied by the Contractor]	No.	7221.46	4	28886.00	
79	(10)414	Fixing of EKT instrument with (or) without crank handle or on suitable fixtures at station/apparatus case, provision of economiser push switch with locking facility, wiring with wire PVC 16/0.2mm copper, provision of teakwood terminal box covered with decolum along with locking facility and painting.(Supply of electric key transmitter and crank handles is not covered in this schedule). [wire PVC 16/0.2mm copper, wire wound resistance, decolum covered terminal box with locking facility by using 25mm thick teak wood, bolts and nuts, paints, push switches, padlocks and other miscellaneous materials required for this work shall be supplied by the contractor]	No.	5239.88	4	20960.00	Consignee

80	(10)417	Supply and installation of magneto telephone handle type and supply and wiring of Ni-cad power pack 4V- 2.2AH with charger to work on 110VAC, at the station house, LC Gate and top points. [Magneto telephone handle type with Ni-cad power pack 4V-2.2AH with charger to work on 110VAC, wire PVC 16/0.2mm copper, and all other miscellaneous materials shall be supplied by the Contractor.]	No.	10996.84	30	329905.00	Consignee
81	(10)426	Supply of 2 pin socket - 5A with switch, fixing the same on the hardwood plank available and extending the 110VAC using wire PVC 3/0.75mm copper, in all the apparatus cases, as per the instructions of K-RIDE representative at site. [2 pin socket - 5A with switch, wire PVC 3/0.75mm copper and all other miscellaneous materials required for the work shall be supplied by the Contractor].	No.	708.44	30	21253.00	
82	(10)501	Releasing of existing relay racks/ cable termination racks along with all the terminals, fuse blocks, relays, with jacks, holding clips etc., 50 way boards, terminals, connecting wires, cables etc., carefully without causing any damage, accounting and stacking them neatly at a place as instructed by Railway representative at site. After releasing, the floor shall be levelled and cement plastered.	Per Rack	1902.37	10	19024.00	
83	(10)502	Releasing of existing Route Indicators of different types including tail cables, carefully without causing any damage, accounting and stacking them neatly at a place as instructed by K-RIDE representative at site.	No.	1483.19	24	35597.00	
84	(10)503	Breaking of concrete and releasing of STOP board/Warning board/ LEGEND boards along with rails, accounting and stacking them neatly at a place as instructed by K-RIDE representative at site. Also the resultant pits shall be re-surfaced and consolidating by ramming and levelling.	No.	1520.57	10	15206.00	
85	(10)507	Releasing of existing apparatus cases (full/ half/ quarter size) without damage after releasing the shelf planks, Terminal blocks, Fuse blocks, Terminal boards, Relays of all types EKTs, Secondary Cells, power equipments, 'E' type locks etc., and breaking the concrete foundation. After releasing, the resultant pits are to be closed and consolidated by ramming and levelling. The released materials shall be accounted and stacked at a place as instructed by K-RIDE representative at site.	No.	2892.95	100	289295.00	
86	(10)508	Breaking of concrete and releasing the existing cable termination boxes, after releasing the base plank, Terminal blocks, Fuse Blocks, Terminal Boards, cut rails, pipes, etc., closing the resultant pits and consolidating it by ramming and levelling. The released materials shall be accounted and stacked neatly at a place as instructed by K-RIDE representative at site.	No.	1929.08	40	77163.00	
87	(10)509	Releasing of existing SM's control panel including base plank, and other gadgets connected very carefully without causing any damage to the panel, accounting and stacking them neatly at a place as instructed by Railway/K-RIDE representative at site. The resultant pit in the flooring shall be removed of all cable bits, levelled and cement plastered.	Set	5058.32	1	5058.00	
88	(10)510	Dismantling and releasing of existing Colour light Signals complete (upto 4 aspects) with or without Route Indicators, calling on signals, shunt signals etc., carefully without any damage to the gadgets, accounting and stacking them neatly at a place as instructed by K-RIDE representative at site. The work includes breaking the concrete foundation, closing the resultant pit and resurfacing it by ramming and levelling.	No.	2966.37	24	71193.00	
89	(10)511	Dismantling and releasing of existing Point machines (all types) including ground connections and other accessories available complete without any damage to the gadgets, accounting and stacking them neatly at a place as instructed by K-RIDE representative at site.	No.	2596.58	2	5193.00	

90	(10)513	Releasing of Secondary cells and battery stands available in the battery room along with connecting strips, wires and terminal boxes carefully without causing any damage to the batteries, accounting and stacking them neatly at a place as instructed by Railway/K-RIDE representative at site. After releasing any holes in the walls/ flooring shall be filled with cement mortar and plastered.	Set	5191.82	2	10384.00	
91	(10)514	Releasing of existing Block Instruments (all types), Block counters, batteries, block filter, block bell equipment etc., carefully without any damage, accounting and stacking them neatly at a place as instructed by K-RIDE representative at site.	No.	1706.13	2	3412.00	
92	(10)517	Releasing of existing ground type shunt signals along with surface base, signal post etc carefully without any damage, accounting and stacking them neatly at a place as instructed by K-RIDE representative at site. The work also includes breaking and removal of concrete foundation and refilling of the resultant pit by ramming and levelling.	No.	2113.31	15	31700.00	
93	(10)518	Releasing of existing TLD boxes with stumps and terminals after releasing all the bond wires. The released materials shall be accounted and stacked neatly at a place as instructed by K-RIDE representative at site.	No.	153.26	250	38315.00	
94	10_519	Releasing of all power equipments including equipment stands, terminal boards, power panel etc., in the power room carefully without causing any damage to the equipments after disconnecting all the supply wires. The released equipments shall be accounted and stacked at a place as instructed by Railway representative at site. After releasing any holes in the walls/ flooring shall be filled with cement mortar and plastered.	Set	12161.85	2	24324.00	
95	(10)520	Releasing of existing control equipments - complete including way station equipments, telephones, powersupply for way station equipment and telephones, along with all wiring, accounting and stacking them neatly at a place as instructed by Railway/K-RIDE representative at site.	Set.	5784.56	1	5785.00	
96	(10)521b	Transportation of Signalling materials by road as per the instructions of K-RIDE representative at site. The work also includes loading and unloading of the aterials. (b) Transportation more than 100 Kms.	Ton Km.	13.39	10000	133900.00	
97	10_522	Engaging mechanical excavators like JCB or other machineries for regarding and levelling the formation, dismantling any infringing structures, clearing and removing debris etc., with all leads and lifts etc., complete and as per the instruction of Railway representative at site.	per hour	1157	20	23140.00	
Total in Rupees						1,59,11,184.00	

Name of the work-Signaling Out door and indoor works with Distributed Electronic interlocking (EI) at Yesvantpur Jn. in connection with doubling of Yesvantpur-Channasandra section of Bangalore Division.						
Schedule - B(Supply)						
Sl. No.	Description	Unit	Rate in Rs.	Quantity	Amount in Rs.	Inspection By
1	Cable termination racks size 880mm X 2 Meters made out of 50mm X 50mm X 6mm thick MS angle powder coated with stainless steel nuts and bolts for fixing the racks with suitable holes for hylem sheet complete as per standard practice with tripod bases and reel insulators. Cable ladder of 400mm x 2000mm be provided at both sides with angle size 40mm x 4mm x 5mm with supporting flate of size 25mm x 5mm.	No.	8846.50	6	53079.00	Consignee
2	Supply of Non-deteriorating (ND) type of fuse holders for Railway signalling, rated voltage 240 AC/DC to Specn. No. IRS S.78/92 (IRS-S-78/97 tentative) IS:13703 (part 2/sec2):1993 suitable for E1 fuse 20Amps SC-20 Holder Safe clip / knife edge type size E1 (R-SS) amp. Fuse block for fuse catridge.	No.	263.90	100	26390.00	Consignee
3	Non-Deteriorating type of fuse holders and fuse links of following rating. (b) Fuse Link 20 Amps. IRS Spec.S.78/92 or latest.	No.	29.34	20	587.00	RDSO
4	Non-Deteriorating type of fuse holders and fuse links of following rating. (c) Fuse Link 10 Amps IRS Spec.S.78/92 or latest.	No.	26.98	20	540.00	RDSO
5	Non-Deteriorating type of fuse holders and fuse links of following rating. (c) Fuse Link 2 Amps IRS Spec.S.78/92 or latest.	No.	22.97	60	1378.00	RDSO
6	High Density Polyethylene Pipes (HDPE) of 110 mm outer Dia, 10 mm Wall thickness, along with one coupler for every 6 Mtrs. as per specification No. IS 4984: 2016 with latest ammendments and Material grade: PE 80.	Mtr.	877.50	3000	2632500.00	RITES
7	Basic material to construct unit maintenance free earth as per RDSO Spec No. RDSO/ SPN/197/2008 or latest and as per Technical specification.	Set	29614.00	50	1480700.00	RITES
8	Printed and bounded registers including maintanance registers for SSDAC, point machine, track circuit etc., (100 pages each of 75 gsm paper)	No.	283.40	30	8502.00	Consignee

This is only for reference

9	Permanently Lubricated High Density Polyethylene duct (PLB-HDPE), 40/33 mm Dia, along with end cap, end plug, Cable sealing plug and couplers, as per RDSO/SPN/TC/45/2013 Rev.2 (upto Amdt.2) or latest.	Km.	89100.00	6	534600.00	BITES
10	Supply of jointing kit conforming to RDSO specificaiton No.IRS-TC 77/2006 Rev.1 or latest for 6 quad cable.	No.	3500.00	8	28000.00	RDSO
11	Supply of Universal AC/DC LED Numeric Route indicator for 1-9 routes with optical sensing and complete housing for use with LED ECR.	No.	200000.00	5	1000000.00	Consignee
12	Flex printing with Sun board fixing of various drawing with Colour (Power board diagram, Relay index chart,Station Rule Diagram, FTOT particulars, etc.), as per instructions of site In-Charge Railway representative.	Sq feet	583.70	300	175110.00	Consignee
Schedule-B total in Rupees					59,41,386.00	

Name of the work -Signaling Out door and indoor works with Distributed Electronic interlocking (EI) at Yesvantpur Jn. in connection with doubling of Yesvantpur-Channasandra section of Bangalore Division.						
Schedule -C (Execution)						
Sl.No.	Description	Unit	Rate in Rs.	Quantity	Amount in Rs.	Inspection By
1	Erection of CT Rack with scaffolding suitably concreting tri-pod bases and reel insulators with "J" bolts and nuts. Tripod and other supportings are to	No.	6221.02	6	37326.00	
2	Track crossing by Horizontal boring method based on RDSO Report No. BS - 105. This also includes insertion of HDPE Pipe of 110mm outer dia in the bore	Mtr.	3214.00	3000	9642000.00	
3	Termination of main, tail, Signalling and power cables and internal wiring on terminal/ fuse blocks in cable termination rack at relay room. The work includes fixing of all new cables by teakwood clamp on teakwood base plank, fixing of Hylem sheet 10 mm thick for terminal board , varnishing all teakwood items, fixing of terminals/ fuse blocks on the terminal board, drilling of necessary holes, termination of cables, wiring, identification of cables using aluminium tags with letters punched neatly, as per approved circuit diagram and cable plan, painting of particulars on sleeves . After terminations are over, cable entry at the bottom shall be closed with , cement plastered, the inter-space filled with sand upto base level and the bottom surface shall be sealed with sealing compound. Cable armour to be soldered to earth. (Supply of cable termination racks and all types of terminals are not included in this schedule). [All bolts and nuts with washers, Hylum Sheet 10 mm Thick, cement, sand, stone jelly, Teak wood base , paints and all other miscellaneous materials required for the work shall be supplied by the contractor] a. Termination on 25/60mm PBT terminals	Per terminal	204.48	2200	449856.00	
4	Provision of 2 Machine cut grooves in parallel at a separation of 8 cms each to a depth of 150 mm in the platform surfaced/tiled floor for laying cable.	Mtr.	957.08	300	287124.00	
5	Concreting of cable laid in the trench or GI pipe/DWC/HDPE pipe in which cable is already laid to a size of 300 x 300mm with 1:3:6 mortar. (All the materials required for the work should be supplied by the contractor)	RMT.	702.90	600	421740.00	

This is only for reference

6	Excavation of pit, erection of cable termination boxes on Rails/L-angles and concreting as per DRG. No. SG/CN/02/8, drilling of suitable holes in the box, fixing of 2 Nos. of GI pipes 32mm dia and 300mm long at the bottom with clamp nuts - 12 mm thick, one at the inner side and another at the outer side for each pipe for cable throughing and one GI pipe 150mm long 32mm dia for drawal of jumper wires for Point machines etc, provision of one EWS lock and painting the boxes inside and outside with one coat of red-oxide and two coats of aluminium paints. (CT Boxes, Cement, sand, stone jelly of size 20/25mm, paint, varnish, GI pipes 32mm dia - 300mm long - 2 Nos and 150mm long - 1 No., clamp nuts -12mm thick - 2 Nos. for each pipe, fixing bolts and nuts with washers, EWS locks and all other items required to be supplied by contractor).	No.	7517.48	30	225524.00
7	Installation of Unit Maintenance free earth pit as per RDSO specification No.RDSO/ SPN/197/ 2008 or latest and as per Technical Specification.	Set	17507.18	50	875359.00
8	Strengthening of foundations of signals, Full/Half location boxes, by carrying out the earth work around the foundation, ramming of the earth, carrying out masonry work from bottom of earth work using country stones and cement masonry to prevent the earth from slipping down the bank.	No.	6583.12	28	184327.00
9	Provision of normal joint of Heat shrinkable type complete for 6 quad cable. After the jointing the through cable has to be tested for insulation resistance and loop resistance in presents of K-RIDE Engineer and in case of any defects the jointing has to be done at free of cost by the contractor. [Heat Shrinkable jointing kit conforming to RDSO specificaion No.IRS-TC 77/2006 covered in the supply portion has to be used for this purpose. The Contractor should supply all other small items free of cost which are required for making a joint. Only gas blower to be used for blowing].	No.	3553.00	8	28424.00
10	Releasing of Diesel Generators in the existing room along with all other	No.	6666.00	2	13332.00
Schedule-C total in Rupees					1,21,65,012.00

Name of the work -Signaling Out door and indoor works with Distributed Electronic interlocking (EI) at Yesvantpur Jn. in connection with doubling of Yesvantpur-Channasandra section of Bangalore Division.						
Schedule -D (Supply & Installation)						
Sl. No.	Description	Unit	Rate in Rs.	Quantity	Amount in Rs.	Inspection By
1	Preparation of Cable Route Plan, Cable Core Plan, Cable Termination Rack Particulars, Location Box Particulars, Power Supply Diagram, Track Circuit Bonding Diagram and/or any other drawing on Auto- CAD in A2/A3/ A4, etc. size (as per instructions of Engineer in-charge). Initially Contractor shall submit 2 sets of 'AS PLANNED' documents complete for approval of Railway/K-RIDEs. One set is returned either duly approved for making a fair copy or for re-submission for approval after incorporating the changes as required by Railway/K-RIDEs. After preliminary approval, execution of work shall be carried out at site. After Completion of work, 2 sets of 'AS MADE' Check Prints are submitted for Administrative approval. Railway/K-RIDEs will return one set to the contractor duly approved with alterations/corrections if any. The contractor shall incorporate Railway/K-RIDEs alterations/corrections in the tracings without any deviation and submit all tracings complete in all respect along with its soft copies in USB Pen Drive and 6 sets of final completion drawings in properly bound booklets. (For station with distributed EI)	Per Station	103917.10	1	103917.00	
2	Supply and fixing of retro-reflective type Calling-On/STOP/BSLB/Legend boards as per practice & SEM .	No.	7616.16	12	91394.00	Consignee
3	Supply and Placing of Polyolefin cable channel of size, width 240/340 mm, height 155/230 internal/external, length 1 Mtr. produced of polyolefin with Fire protection class k-1 in accordance with DIN-53438 Part II for laying Signalling/Telecom cables, channel attachable to each other with male-female swallow tail connectors and having suitable detachable cover.	Mtr.	2700.00	3000	8100000.00	RITES

This is only for reference

4	Supply and laying of Split DWC pipe of 120/103 mm dia, 2 Mtr. long in already dug cable trenches. The unit of RMT means two split pipes of 1 Mtr. each. Material shall be supplied as per specification RDSO/SPN/204/2011 or latest.	RMT	309.00	3000	927000.00	RITES
5	Supply and fixing of 2 conductor dis connecting terminal block for 2.5sq.mm wire termination, make - wago/phoenix or similar with all accessories	Nos	250.00	900	225000.00	Consignee
Schedule-D total in Rupees					94,47,311.00	

Name of the work-Signaling Out door and indoor works with Distributed Electronic interlocking (EI) at Yesvantpur Jn. in connection with doubling of Yesvantpur-Channasandra section of Bangalore Division.						
Schedule -E (Electronic interlocking (EI))						
Sl. No.	Description	Unit	Rate in Rs.	Quantity	Amount in Rs.	Inspection By
1	Design, manufacture and supply of Distributed Electronic interlocking(EI) system "Hot stand by mode" (Distributed installation and suitable for Yesvantpur station complete as per RDSO Specification No. RDSO/ SPN/203/2011 or latest with amendments, as per Special Conditions of Contract and technical specification, including all fixtures, interconnection cables and jumper wires, mounting arrangement and accessories to make the EI system functional Yesvantpur station. This item also includes the following 1) Designing of EI Software (application logic, interface circuits etc.) including operator and maintenance VDU software as per tentative yard plan enclosed along with the tender document. 2) Supply and provision of Ring earthing arrangements for Central EI and Goompties as per RDSO specifications RDSO/SPN/197/2008. 3) Arrangement of FAT and SAT. 4) Supply and provision of required communication equipments to make the EI system functional. 5) Supply and provision External SM key and Counters Box. 6) Supply and provision of 230v AC/110v DC SPD class 'D' Type, 6) The successful tenderer should give detailed cost wise and quantity wise break up of all items and components on issue of LOA. 7) Accessories such as managed Ethernet switch, RS232, isolator etc., as required to interface EI with VDU is covered under this schedule. The system shall have provision for accommodating additional 15% of I/O in the form of unused I/O cards slots or the unused bits in installed cards. All special relays shall be supplied by Contractor except QN1,QNA1, QBCA1 and QECX, having operating voltages i.e., 24V DC, which are in the scope of other schedules.	Per Stn.	59062577.76	1	59062578.00	RDSO

	Refer the Technical Specifications for EI for full descriptions.					
2	Supply of Essential Spares @ 10% on all kinds of EI module/cards, special relays and DC-DC converters subject to a fractional quantity to be rounded off to next higher digit to be supplied for the Electronic Interlocking against the item No. NS1 of Annexure A2. The list of SPARE items with unit rate, number and total cost should be detailed by the contractor. Inspection by RDSO	Per Stn.	5733519.84	1	5733520.00	RDSO
3	Installation, testing and commissioning of Distributed version of EI equipment supplied vide sl. no.1 as per RDSO Specification No. RDSO/SPN/ 203/2011 and as per RDSO TAN and as detailed in Sl. No. 1 of Sch-E, including supply and installation of relay racks and fixing & wiring of all types of relays, termination of interface wires on the CT rack (FTOT) and painting of sleeve particulars in all 3 locations (station with 2 Goompty) .	Lumpsu m	4154443.20	1	4154443.00	
4	Supply, Installation, wiring, testing and commissioning of Datalogger as per RDSO IRS/99/2006 or latest with EI interface card (Digital interface cards), for 512 digital inputs and 32 analog inputs. This includes supply of all miscellaneous items and software for commissioning of datalogger with networking.(including Fault analyses terminal ,printer, mounting table and revolving chair of reputed firm make as per details in Technical specification)	Nos	852000.00	3	2556000.00	RDSO

This is only for reference

5	Supply of Online UPS of 1 KVA capacity input voltage 160V AC - 280 V AC, output voltage 230V AC, Operating Freq 47-63 Hz with back up time 30 min (APC or Emerson)	Nos	27072.00	3	81216.00	Consignee
6	Training of Railway Personnel for installation, testing, commissioning, trouble shooting, alteration and repair of EI . This includes Supply of compiler for doing trouble shooting/ modification in logic circuits, hard and soft copies of Course modules and working instructions. Training shall be imparted preferably at worksite/Railway depot of the Engineer in charge/ Manufacturer's factory premises. Training materials may be supplied by the contractor.	Man days	3273.12	20	65462.00	
7	Supply of instruments and tool kits required for trouble shooting & repair of hardware and software for EI. List of tools to be supplied as mentioned in technical specifications.	Per set	112862.00	1	112862.00	Consignee
8	Supply of Asmade documents for indoor signalling arrangements(EI) of Yeshwanthpur Yard. All asmades shall be prepared by the contractor in Auto cad2000 or latest and submitted in CD/pendrive. One copy of the Asmades check print shall be submitted before testing the circuits. The final negatives shall be made in tracing sheet(80-90 GSM). All asmades except cable plan, cable route plan, bonding diagram shall be prepared in A3 size. On approval the contractor shall submit along with the negatives 6 copies in each duly making booklet neatly bound. Out of 6 sets, 2 sets of drawing and other plans shall be kept in transparent plastic cover (2 sheets back to back in one plastic cover) and handed over to Railways. Also the contractor has to supply one set of Asmades in Reproduction Film.	Set	382950.00	1	382950.00	

This is only for reference

9	Supply, installation and commissioning of class 'A' protection with lightening event counter as per RDSO spec. No.RDSO/SPN/197/2008 and as per details given in Technical specification with three year warranty.	Set	468720.00	4	1874880.00	RDSO
10	Supply, installation, wiring, testing and commissioning of complete Integrated Power Supply systems (SMPS based) as per RDSO Spec No.: RDSO/SPN/165/2012 (Ver.3.0) with latest ammendment with STR No. SIQ0110 ver.3.0 or Latest along with status monitoring panel as per drawing attached as Annexure -A,B & C with Battery set (55 plus 5 spare cells) 60 Nos. of 110V/200Ah (LMLA) suitable for EI with RE area upto 6 lines. Battery connecting wire of 16 sqmm multi strand copper cable(Red-50 Mtrs, Block - 50 Mtrs & Green - 50 Mtrs.) required for inter connection IPS and power distribution board and wiring should be done neatly using powder coated alluminum ladder as per site requirement and direction of site Engineer	Set	1591068.34	3	4773205.00	RDSO
11	Supply and Installation of commercial grade Operator VDU. The operator VDU of size 85" UHD monitor including all accessories. The monitor should be capable of working on 110 V AC. The embedded PCs for Operator VDU should be as per RDSO TAN No. STS/E/TAN/3012 Version 3.0 or latest with adequate storage memory to work in hot-standby mode. The VDUs should be provided with all necessary software to work along with EI equipment. Necessary mounting arrangements also should be provided for operator VDU.	Nos	1480000.00	2	2960000.00	

This is only for reference

12	Supply and Installation of commercial grade Maintener VDU of size 65" full HD for maintenance terminal. The monitor should be capable of working on 110 V AC. The embedded PCs for Operator VDU should be as per RDSO TAN No. STS/E/TAN/3012 Version 3.0 or latest with adequate storage memory to work. The VDUs should be provided with all necessary software to work along with EI equipment. Necessary mounting arrangements also should be provided for Maintener terminal.	Nos	850000.00	1	850000.00	Consignee
13	Supply and installation of VDU Panel operator console (Table) in SM Room new modular/Pyrotech make or better for complete specification and drawing refer technical specification. work space (SM table) as per enclosed drawing (as approved by Engineer in charge) with control desk for 2 monitors of min 85" size, 2 operators & one module to be provided for storage - should include space for housing 2 Nos. of embedded PCs, 2 Nos. of FDMS and their Power supply arrangement for with proper ventilation - Two chairs (Godrej PCH7002DX or superior as approved by officer in charge)	Set	856240.00	1	856240.00	Consignee
14	Supply and provision of modular power supply arrangements for operator and maintenance VDU PC, MT PC and embedded PC. This consists of i) 110V DC/110V AC 500vA inverter - 2 Nos, ii) 110V DC/24V DC 10A - 3 Nos. Gallant make or better (This includes suitable enclosure/fixture as per site requirement)	Set	190299.12	1	190299.00	Consignee

This is only for reference

15	Supply and fabrication of table having dimensions 2.5 Mtr x 1 Mtr (Featherlite or Better make) (or dimension as per site requirement) for accommodation of maintenance terminal including Printer arrangements. This includes supply of one chair (Godrej PCH7002DX or superior) as approved by Engineer in charge	Set	27800.00	1	27800.00	Consignee
16	Supply, installation, testing and commissioning of relay based mobile emergency panel. This includes supply of domino type panel, buttons, knob, LED fixtures and wiring of circuit provided by K-RIDE. (supply of relays not covered in this schedule). Necessary circuit for wiring will be provided by K-RIDE. all other required materials will be supplied by Contractor.	Station	279053.28	1	279053.00	Consignee
Sch- E total in Rupees					8,39,60,508.00	

Name of the work-Signaling Out door and indoor works with Distributed Electronic interlocking (EI) at Yesvantpur Jn. in connection with doubling of Yesvantpur-Channasandra section of Bangalore Division.						
Schedule -F (Fire Alarm)						
Sl. No.	Description	Unit	Rate in Rs.	Quantity	Amount in Rs.	Inspection By
1	Supply of aspiration type smoke detector. Highly sensitive smoke aspiration system for monitoring of rooms and equipment's for earliest possible fire detection For Relay rooms as per RDSO spec No.RDSO/SPN/217/2018 Ver.2.0 or latest.	No.	683317.50	3	2049953.00	RDSO
2	Supply of single Loop Analog addressable Fire Alarm system with loop capacity of connecting maximum 50 devices. The panel shall have a built in power supply and battery charger as per RDSO Spec. No.RDSO/SPN/217/2018 Ver.2.0 or latest.	No.	300781.67	3	902345.00	RDSO
3	Supply of Multi Sensor detector Dual Optical/Thermal with rotaries and back boxes including base as per RDSO Spec. No.RDSO/SPN/217/2018 Ver.2.0 or latest.	No.	15481.18	32	495398.00	RDSO
4	Supply of Addressable Single action indoor manual call point with back box(RED) and also including key as per RDSO Spec. No.RDSO/SPN/217/2018 Ver.2.0 or latest.	No.	9162.33	3	27487.00	RDSO
5	Supply of Sounder having range of 81 dbA to 92 dbA as per RDSO Spec. No.RDSO/SPN/217/2018 Ver.2.0 or latest.	No.	11021.25	3	33064.00	RDSO
6	Supply of Intelligent addressable Monitor module as per RDSO Spec. No.RDSO/SPN/217/2018 Ver.2.0 or latest.	No.	9162.33	3	27487.00	RDSO
7	Supply of Intelligent addressable control module as per RDSO Spec. No.RDSO/SPN/217/2018 Ver.2.0 or latest.	No.	9162.33	3	27487.00	RDSO

This is only for reference

8	Supply of Addressable Zone Module as per RDSO Spec. No.RDSO/SPN/217/2018 Ver.2.0 or latest. (Inspection by RDSO)		9162.33	3	27487.00	RDSO
9	Auto-dialer for SMS alarm generation & routing in case of Fire Alarm to concerned persons as per RDSO Spec. No.RDSO/SPN/217/2018 Ver.2.0 or latest.	No.	42395.08	3	127185.00	RDSO
10	Supply of 2core 1.5sq.mm FRLS Cooper unarmored cable with necessary clamps and fittings as per RDSO Spec. No.RDSO/SPN/217/2018 Ver.2.0 or latest.	Mtr.	286.55	500	143275.00	RDSO
11	Supply of LHS Cable as per RDSO Spec. No.RDSO/SPN/217/2018 Ver.2.0 or latest.	Mtr.	2167.51	400	867004.00	RDSO
12	Supply of LHS control module as per RDSO Spec.No.RDSO/SPN/217/2018 Ver.2.0 or latest.	No.	150216.70	3	450650.00	RDSO
13	Supply of Co2 fire extinguisher 4.5 Kg capacity conforming to ISI5683 with ISI mark provided with all fitting and accessories. Make:Safex/Bharat or similar.	No.	26451.00	12	317412.00	
14	Installation, testing and commissioning charges of fire alarm system including programming of devices and fire alarm panel etc.,	Per Station	92578.50	3	277736.00	
15	Supply and Installation of Air sampling CPVC Pipes with all required accessories for Aspiration system.	Per Station	73475.00	3	220425.00	RDSO
16	Supervision, programming , Installation, testing & Commissioning of Aspiration smoke detection.	Per Station	80822.50	3	242468.00	
Sch-F total in Rupees					62,36,863.00	

Name of the work -Signaling Out door and indoor works with Distributed Electronic interlocking (EI) at Yesvantpur Jn. in connection with doubling of Yesvantpur-Channasandra section of Bangalore Division.						
Schedule -H (Axle Counters)						
Sl. No.	Description	Unit	Rate in Rs.	Quantity	Amount in Rs.	Inspection By
1	Supply and installation of Multi section Digital Axle counter (MSDAC) as per RDSO specification no.RDSO/SPN/176/2013 version.3.0 with latest amendments for Yesvantpur station. a) Supply of Multi section Digital Axle counter (MSDAC) consists of i) The tenderer shall design the scheme for provision of required number of Evaluators, track side junction Boxes, detection points etc. ii) MSDAC application in the yard shall be in place of track circuits with single detection, IB application shall be with dual detection. iii) length of cable required for each track devided-5/10/15 mtrs. b) Installation, Design, wiring, testing and commissioning of Multi section digital axle counter outdoor and indoor work	Per DP	682611.22	115	78500290.00	RDSO
2	Supply of essential 10% spares (for 115 DPs) covering all types of cards, wheel sensors for MSDAC. Detailed cost and quantity wise break up of all spares should be given.	Set	3778670.00	1	3778670.00	RDSO
3	Tool set for wheel sensor mounting and maintenance of MSDAC consisting of torque wrench, ratchet, testing plate, measuring tape, scew driver, hand gloves & multi meter fluke115 or better.	No.	105000.00	1	105000.00	Consignee
Schedule-H total in Rupees					8,23,83,960.00	

Name of the work -Signaling Out door and indoor works with Distributed Electronic interlocking (EI) at Yesvantpur Jn. in connection with doubling of Yesvantpur-Channasandra section of Bangalore Division.						
Schedule -J (Cables)						
Sl. No.	Description	Unit	Rate in Rs.	Quantity	Amount in Rs.	Inspection By
1	Supply of Railway signalling cable 2 core x 2.5 sq.mm. confirming to spec. no. IRS:S- 63/2014 Rev 4.0 with latest ammendment if any.	Mtr.	109.10	2000	218200.00	RDSO
2	Supply of Railway signalling cable 12 core X 1.5 sq.mm. confirming to spec. no. IRS:S- 63/2014 Rev 4.0 with latest ammendment if any.	Mtr.	268.00	33000	8844000.00	RDSO
3	Supply of Railway signalling cable 19 core X 1.5 sq.mm. confirming to spec. no. IRS:S- 63/2014 Rev 4.0 with latest ammendment if any.	Mtr.	373.50	20000	7470000.00	RDSO
4	Supply of Railway signaling cable 30 core x 1.5 sq.mm confirming to spec. no. IRS:S- 63/2014 Rev 4.0 with latest ammendment if any	Mtr.	528.60	16000	8457600.00	RDSO
5	Supply of PVC insulated steel strip armoured, unscreened, copper conductor of size 2core X 10 sqmm power cable straned 7 x 1.4 mm for confirming to spec. no. IRS:S-63- 2014 Rev 4.0 & IS:1554 (Part-1) with latest ammendment if any.	Mtr.	211.81	10000	2118100.00	RDSO
8	Supply of 24 fibre armoured Optic Fibre Cable as per Spec. No.IRS: TC.55/2006 REV.1 with Ammendment 1.1 or latest in any.	Mtr.	104.21	6000	625260.00	RDSO
10	Supply of Railway Underground Jelly filled, 0.9mm dia, 6 Quad cable as per Spec. No. TC/30/2005 version-1 with Ammendment 4 or latest in any.	Mtr.	416.55	22000	9164100.00	RDSO
Schedule-J total in Rupees					3,68,97,260.00	

This is only for reference

Name of the work-Signaling Out door and indoor works with Distributed Electronic interlocking (EI) at Yesvantpur Jn. in connection with doubling of Yesvantpur-Channasandra section of Bangalore Division.						
Schedule -K (LED Signal Aspects)						
Sl. No.	Description	Unit	Rate in Rs.	Quantity	Amount in Rs.	Inspection By
1	Supply of LED Signal unit for Red aspect integrated type as per spec. No. RDSO/SPN/199/2010 Rev 1.0 or latest.	No.	13394.25	35	468799.00	RDSO
2	Supply of LED Signal unit for Yellow aspect integrated type as per spec. No. RDSO/SPN/199/2010 Rev 1.0 or latest.	No.	13394.25	36	482193.00	RDSO
3	Supply of LED Signal unit for Green aspect integrated type as per spec. No. RDSO/SPN/199/2010 Rev 1.0 or latest.	No.	13394.25	20	267885.00	RDSO
4	Supply of calling on LED 110V AC as per spec. No. RDSO/SPN/153/2011 Rev 4.1 or latest.	No.	8596.80	26	223517.00	RDSO
5	Supply of Junction type route indicator LED 110VAC as per spec. No. RDSO/SPN/153/2011 Rev 4.1 or latest.	No.	8596.80	150	1289520.00	RDSO
6	Supply of shunt signal LED 110V AC as per spec. No. RDSO/SPN/153/2011 Rev 4.1 or latest.	No.	8596.80	110	945648.00	RDSO
Schedule-K total in Rupees					36,77,562.00	

Name of the work -Signaling Out door and indoor works with Distributed Electronic interlocking (EI) at Yesvantpur Jn. in connection with doubling of Yesvantpur-Channasandra section of Bangalore Division.						
Schedule -L (Misc. Items)						
Sl. No.	Description	Unit	Rate in Rs.	Quantity	Amount in Rs.	Inspection By
1	Video recording of trench which is made for cable laying shall be submitted in soft copy in USB pen drive.	Km.	3119.00	6	18714.00	
2	Installation, termination, wiring, testing and commissioning of Point machine (220mm throw) including supply of wire, GI bend pipe, insulation sets etc.	Per Point M/c.	18861.15	4	75445.00	
3	Provision of one skilled and one unskilled staff round the clock to attend to teething trouble of the installation along with K-RIDE official after the installation has been brought into commissioning. The work includes routine maintenance, failure restoration as per the direction of the K-RIDE official.	Per Month	63495.00	12	761940.00	
4	Provision of lookout person round the clock in 12 hours shift beat from Up Home Signal to Down Home Signal to avoid theft of signalling assets.	Per 12 Hours	744.00	360	267840.00	
5	Providing services of helping hand man power to carry out miscellaneous/sundry works in the office/field between 08.00 hrs and 20.00 hrs of the day and accompanying Railway/K-RIDE staff with all expenses of transportation, accomodation, food, consumables etc., with all ascents/descents, taxes, octroi, cess, fees, duties, with contractors tools and plants, materials, consumables, labour, crew, machineries with all lead and lift etc., complete as per special conditions, specification, regulation and as directed by Railway Engineer-in-charge	Man day	657.00	250	164250.00	
6	Supply and Laying of PVC warning tape colour orange, width of 250mm (10") by printing with black letters 'Indian Railway Signal/Telecom/OFC Cable' on both sides.	Km.	42600.00	6	255600.00	Consignee
7	Supply and provision of MS Cable Tray of thickness 1.6 mm, including top cover for closing, with all required miscellenous materials for installation. Installation to be carried out as per the instructions of site engineer. MS cable tray including cover should be powder coated with Siemens gray color. -MS cable tray - 400mm x 300mm.	RMT.	4420.00	12	53040.00	Consignee

8	Supply and provision of MS cable tray of thickness 1.6 mm, including top cover for closing, with all required miscellenous materials for installation. Installation to be carried out as per the instructions of site engineer. MS cable tray including cover should be powder coated with Siemens gray color. -MS cable tray - 400mm x 150mm	RMT.	3678.00	12	44136.00	Consignee
9	Supply and provision of MS cable tray of thickness 1.6 mm, including top cover for closing, with all required miscellenous materials for installation. Installation to be carried out as per the instructions of site engineer. MS cable tray including cover should be powder coated with Siemens gray color. -MS cable tray - 250mm x 100mm.	RMT.	2806.00	12	33672.00	Consignee
10	Supply and provision of MS cable tray of thickness 1.6 mm, including top cover for closing, with all required miscellenous materials for installation. Installation to be carried out as per the instructions of site engineer. MS cable tray including cover should be powder coated with Siemens gray color. -MS cable tray - 100mm x 100mm.	RMT.	1997.00	18	35946.00	Consignee
11	Laying of PLB HDPE duct, 40/33 mm Dia, in the trenches and in the protective works already provided including in HDD portion and supply pulling of Nylone rope through it at diffeent places as per direction of engineerin charge or site engineer.	Km.	10360.00	6	62160.00	
12	Duct Integrity test for PLB HDPE duct, 40/33 mm Dia, as per specification.	Km.	1287.00	6	7722.00	
13	Blowing of OFC cable (24F as per RDSO specn.TC 55-2006 Rev.1 with amendment 1.1) in already laid PLB HDPE duct, 40/33mm dia, by using blowing machine, providing the sufficient loops in loop/joint chambers and other associated works.	Km.	14793.00	6	88758.00	
14	Supply, installation, testing and commissioning of Earth Leakage detector 12 channel (110V DC, 24V DC, 12V DC etc.) as per RDSO Spec. No.256/2002 or latest with 6 digital counter.	No.	159244.00	3	477732.00	
15	Step ladder aluminum made of BATHLA make Aprox.5 feet height.	No.	8751.00	3	26253.00	
16	Fabrication and Supply of wall mounted maintainers Tool kit frame made out of MS sheet 10 Guage with powder coated as desired colour at site of size 1.0 Mtr Length x 0.8 Mtr Width x 0.15 Mtr Depth with all fixtures for mounting individuals, tools inside the board and in front with Acrylic sheet 4 mm thickness with locking arrangements and all necessary fixtures to fix on wall.	No.	14700.00	3	44100.00	

17	Supply and erection of Power rack (1000mm x 2000mm) with Modular Terminal Blocks, Fuse Terminal Blocks & Fuse Link of International Standard for Railway Signaling (minimum 60 pairs (+ve fuse and -ve links) Wago / Phoenix terminals suitable for 10 sq.mm power cables as per Spec. No. RDSO/SPN/189/2004 Ver.3.0 with RDSO inspection). (All required materials for fixing to be arranged by the Contractor) with necessary inspection as per technical specification / drawing / description enclosed in this document.	No.	144813.00	3	434439.00	
18	Preparation of Station working Rules(SWR), CRS papers etc. as practice in S.W.Rly for yard /LC Gates/IBS	Per Application	22507.00	1	22507.00	
19	Fabrication of wall housing cabinet (Appx. dimensions H=9feet x W=9feet x D=2feet) at SM room with 2 or 3 partitions to house all type of wall mounted equipments like KLCR box, all type telecom equipments including 6 Quad cable termination panel, BPAC reset Box, Electrical CLS panel, SM key Box etc.1) This cabinet will have one glass fronted view door and two normal doors made with 25mm block board with 1mm thick laminate on both side. 2) Cabinet structure shall be made with 19mm green ply or better. 3) Hinges shall have minimum of three year's warranty against manufacturing defects. All the materials required for the fabrication and fixing of wall cabinet shall be supplied by Contractor including Lead, Lift and Man-power. Work need to be carried out to suite at site as per the tentative drawing available at the office of K-Ride and the instruction of site Engineer.	No.	75600.00	1	75600.00	
20	Supply of Daido type single line token less block instrument complete with relays, transmitter with receiver, Filter unit, wooden block counter etc.	Set	483943.00	2	967886.00	RDSO
21	Supply and installation of De-ioniser plant (Aqua-Ion Model No. ACAMB 4 Bed Type).	No.	43374.00	1	43374.00	
22	Steel Alamairah (Model: Godrej Store well/slimline 4S).	No.	21795.00	3	65385.00	
23	Navtal locks Godrej make 75mm with 2 Keys.	No.	615.00	6	3690.00	
Schedule -L total in Rupees					40,30,189.00	

Name of the work -Signaling Out door and indoor works with Distributed Electronic interlocking (EI) at Yesvantpur Jn. in connection with doubling of Yesvantpur-Channasandra section of Bangalore Division.						
Schedule -M (Point Machines)						
Sl.No.	Description	Unit	Rate in Rs.	Quantity	Amount in Rs.	Inspection By
1	a) Supply of Electrical point operating machine IRS Type, 220 mm throw (AC immunity 160 VAC) non trailable to operate on 110 VDC with lock & detector slides, cable termination box and clamp lock arrangement for thick web switches (Drg No. RDSO: S-3395 & S-3454 confirming to IRS:S-24/2002 OR latest, Drg. No. S-11000 & for Motor IRS:S 37/82. b) Supply of Ground connections for Thick web switches - 1 complete set / Point Machine including supply of standard tool kit for every 4 point machines.	No.	213982.70	4	855931.00	RDSO
2	a) Supply of Electrical point operating machine - IRS Type 143 mm throw (AC immunity 160 VAC) non trailable to operate on 110 V DC with lock & detector slides, cable termination box confirming to IRS: S-24/2002 or latest. and for Motor IRS:S 37/82, Assy Drg RDSO-S:10800 and S:10910. b) Supply of Ground connections for 143mm throw IRS type Machine completeset (5 Rods) as per Drg No. (i) SA 8805, (ii) RDSO/S/3273, (iii) RDSO/S/3271, (iv) RDSO/S/3267 (v) RDSO/S/3269, switch extension bracket RDSO/S/3264 and Drive lug S 8806-1 complete set per Point Machine including supply of standard tool kit for every 8 point machines.	No.	103875.92	20	2077518.00	RDSO
Schedule -M total in Rupees					29,33,449.00	

Name of the work -Signaling Out door and indoor works with Distributed Electronic interlocking (EI) at Yesvantpur Jn. in connection with doubling of Yesvantpur-Channasandra section of Bangalore Division.						
Schedule -N (Relays)						
Sl. No	Description	Unit	Rate in Rs.	Quantity	Amount in Rs.	Inspection By
1	Supply of Relay DC QN1 8F/8B plug in type Metal to carbon with plug board, retaining clip and connectors confirming to BRS - 930A & as per RDSO Spec No. IRS- S-34, IRS -S-23 or latest (Code:ABCDE) - (QN1 Contact configuration 8F/8B)	No.	4606.00	350	1612100.00	RDSO
2	Supply of Relay AC immune plug type QNA1 8F/8B Metal to carbon with plug board, retaining clip and connectors confirming to BRS - 931A & as per RDSO Spec No. IRS- S-34, IRS -S-23, IRS-S-60/78 or latest. (QNA1 Contact configuration 8F/8B)	No.	4807.67	500	2403835.00	RDSO
3	Supply of key lock Relay (KLCR) working on 24V DC AC immunised type TMA with different ward combination IRS-S-46, IRS-S-34, IRS-S-23 as applicable with contact configurations 4F/4B)	No.	11210.00	20	224200.00	RDSO
Schedule-N total in Rupees					42,40,135.00	

SECTION-10

FORMAT OF BANK GUARANTEE FOR SECURITY DEPOSIT ETC.,

INDEX

Table of Forms

SL. NO	DESCRIPTION	PAGE NO
1	FORMAT OF BANK GUARANTEE FOR SECURITY DEPOSIT (Not Applicable)	391
2	FORM OF BANK GUARANTEE FOR PERFORMANCE SECURITY	392-394
3	FORM OF BANK GUARANTEE FOR ADDITIONAL PERFORMANCE SECURITY	395-397
4	ADVANCE PAYMENT SECURITY	398-401
5	INDEMNITY BOND FOR THE SAFE CUSTODY OF THE MATERIALS SUPPLIED BY THE CONTRACTOR	402-404

NOTE: *This Section contains forms which, once completed, will form part of the Contract. The forms for Performance Security and Advance Payment Security, when required, shall only be completed by the successful Bidder after contract award.*

All italicized text is for guidance how to prepare the various forms and shall be deleted from the final documents.

FORMAT OF BANK GUARANTEE FOR SECURITY DEPOSIT (Not Applicable)

To,.....(Name of the Employer)
(Address of the Employer).

Whereas(Name and Address of the contractor) (herein after called the Contractor) has undertaken, in pursuance of contract no.....
 Dated:.....(Name of the contract and brief description of the work) (herein after called the Contract)

AND WHEREAS it has been stipulated by you in the said Contract that the Contractor shall furnish you with a Bank Guarantee by a recognized bank for the sum specified therein as security for compliance with his obligations in accordance with the Contract;

AND WHEREAS we have agreed to give the Contractor such a Bank Guarantee;

NOW THEREFORE we hereby affirm that we are the Guarantor and responsible to you, on behalf of the Contractor, up to a total of Rs. _____ [amount of guarantee]
 Rupees _____ [in words], and we undertake to pay you, upon your first written demand and without cavil or argument, any sum or sums within the limits of _____ [amount of guarantee] as aforesaid without your needing to prove or to show grounds or reasons for your demand for the sum specified therein.

We hereby waive the necessity of your demanding the said debt from the Contractor before presenting us with the demand.

We further agree that no change or addition to or other modification of the terms of the Contract or of the Works to be performed there under or of any of the Contract documents which may be made between you and the Contractor shall in any way release us from any liability under this guarantee, and we hereby waive notice of any such change, addition or modification.

This guarantee shall be valid until 28 days from the date of expiry of the Defects Liability Period.

Signature and seal of the guarantor _____
 Name of Bank _____
 Address _____
 Date _____

FORM OF BANK GUARANTEE FOR PERFORMANCE SECURITY

(On non-judicial stamp paper of the appropriate value in accordance with stamp Act. The stamp paper to be in the name of Executing Bank).

From:

Name and Address of the Bank.....
.....

To:

The Managing Director,
Rail Infrastructure Development Company (Karnataka) Limited,
"Samparka Soudha" , 1st Floor,
B.E.P Premises (Opp. Orion Mall),
Dr. Rajkumar Road,
Rajajinagar 1st Block,
Bangalore - 560 010

WHEREAS, Rail Infrastructure Development Company (Karnataka) Limited, hereinafter called the **Employer**, acting through **[Insert Designation and address of the Employer's Representative]**, has accepted the bid of **[Insert Name and address of the Contractor]**, hereinafter called the **Contractor**, for the work of **[Insert Name of Work]**, vide Notification of Award No **[Insert Notification of Award No...]**
AND

WHEREAS, the contractor is required to furnish Performance Security for the sum of **[Insert Value of Performance Security required]**, in the form of bank guarantee, being a condition precedent to the signing of the contract agreement.

WHEREAS, **[Insert Name of the Bank]**, with its Branch **[Address]** having its Headquarters office at **[Address]**, hereinafter called the **Bank**, acting through **[Designation(s) of the authorised person of the Bank]**, have, at the request of the **[Insert name of the JV partner]**, a JV partner on behalf of the contractor, agreed to give guarantee for performance security and additional performance security as hereinafter contained:

- 1 KNOW ALL MEN by these present that I/We the undersigned **[Insert name(s) of authorized representatives of the Bank]**, being fully authorized to sign and incur obligations for and on behalf of the Bank, hereby, unconditionally and irrevocably guarantee to pay the Employer the full amount in the sum of **[Insert Value of Performance Security required]** as above stated.
- 2 The Bank undertakes to immediately pay on presentation of demand by the Employer any amount up to and including aforementioned full amount without any demur, reservation or recourse. Any such demand made by the Employer on the Bank shall be final, conclusive and binding, absolute and unequivocal notwithstanding any disputes raised/ pending before any Court, Tribunal, Arbitration or any Authority or any threatened litigation by the Employer of Bank.
- 3 On payment of any amount less than aforementioned full amount, as per demand of the Employer, the guarantee shall remain valid for the balance amount i.e. the aforementioned full amount less the payment made to the Employer.

- 4 The Bank shall pay the amount as demanded immediately on presentation of the demand by Employer without any reference to the contractor and without the Employer being required to show grounds or give reasons for its demand or the amount demanded.
5. The Bank Guarantee shall be unconditional and irrevocable.
- 6 The guarantee hereinbefore shall not be affected by any change in the constitution of the Bank or in the constitution of the Contractor.
- 7 The Bank agrees that no change, addition, modifications to the terms of the Contract Agreement or to any documents, which have been or may be made between the Employer and the Contractor, will in any way release us from the liability under this guarantee; and the Bank, hereby, waives any requirement for notice of any such change, addition or modification to the Bank.
- 8 This guarantee is valid and effective from the date of its issue, which is ***[insert date of issue]***. The guarantee and our obligations under it will expire on ***[Insert the date Sixty days after the expected end of completion period]***. All demands for payment under the guarantee must be received by us on or before that date.
- 9 The Bank agrees that the Employers right to demand payment of aforementioned full amount in one instance or demand payments in parts totaling up to the aforementioned full amount in several instances will be valid until either the aforementioned full amount is paid to the Employer or the guarantee is released by Employer before the Expiry date.
- 10 The Bank agrees that its obligation to pay any amount demanded by the Employer before the expiry of this guarantee will continue until the amount demanded has been paid in full.
- 11 The expressions Bank and Employer herein before used shall include their respective successors and assigns.
- 12 The Bank hereby undertakes not to revoke the guarantee during its currency, except with the previous consent in writing of the employer. This guarantee is subject to the Uniform Rules for Demand Guarantees, ICC Publication No. 758.
- 13 The Guarantee shall be in addition to and without prejudice to any other security Guarantee (s) of the contractor in favour of the Employer available with the Employer. The Bank, under this Guarantee, shall be deemed as Principal Debtor of the Employer.
14. This guarantee shall be valid for 60 days from the date of expected end of completion period.

Date

Place.....

.....

*[Signature of Authorized person of
Bank/Guarantor]*

.....
[Name in Block letters]

.....

[Designation]

.....
[P/Attorney] No......
Bank's Name and Seal

[P/Attorney] No.....

Witness:

1. *Signature*
Name & Address & Seal
2. *Signature*
Name & address & Seal

Note :

1. *All italicized text is for guidance on how to prepare this bank guarantee and shall be deleted from the final document.*
2. *In case the guarantee is issued by a foreign Bank, which does not have operations in India, the said bank shall have to provide a counter-guarantee by State Bank of India.*
3. *In case the Contractor is a JV, the Performance Security is required to be furnished on behalf of the JV in favour of the Employer by the JV Partners in proportion of their respective percentage share specified in the JV Agreement. The percentage share of M/s **[Insert Name of the JV Partner]** in the JV is **[Fill share % in the JV]** percent. All the Bank Guarantee of JV Partners are liable to be encashed cumulatively.*

FORM OF BANK GUARANTEE FOR ADDITIONAL PERFORMANCE SECURITY

(On non-judicial stamp paper of the appropriate value in accordance with stamp Act. The stamp paper to be in the name of Executing Bank)

From:

Name and Address of the Bank.....
.....

To:

The Managing Director,
Rail Infrastructure Development Company (Karnataka) Limited,
"SamparkaSoudha" , 1st Floor,
B.E.P Premises (Opp. Orion Mall),
Dr. Rajkumar Road,
Rajajinagar 1st Block,
Bangalore - 560 010

WHEREAS, Rail Infrastructure Development Company (Karnataka) Limited, hereinafter called the **Employer**, acting through **[Insert Designation and address of the Employer's Representative]**, has accepted the bid of **[Insert Name and address of the Contractor]**, hereinafter called the **Contractor**, for the work of **[Insert Name of Work]**, vide Notification of Award No. **[Insert Notification of Award No.]**.

AND

WHEREAS, the contractor is required to furnish Performance Security for the sum of **[Insert Value of Performance Security required]**, in the form of bank guarantee, being a condition precedent to the signing of the contract agreement.

WHEREAS, **[Insert Name of the Bank]**, with its Branch **[Address]** having its Headquarters office at **[Address]**, hereinafter called the **Bank**, acting through **[Designation(s) of the authorised person of the Bank]**, have, at the request of the **[Insert name of the JV partner]**, a JV partner on behalf of the contractor, agreed to give guarantee for performance security and additional performance security as hereinafter contained:

- 1 KNOW ALL MEN by these present that I/We the undersigned **[Insert name(s) of authorized representatives of the Bank]**, being fully authorized to sign and incur obligations for and on behalf of the Bank, confirm that the Bank, hereby, unconditionally and irrevocably guarantee to pay the Employer the full amount in the sum of **[Insert Value of Performance Security required]** as above stated.
- 2 The Bank undertakes to immediately pay on presentation of demand by the Employer any amount up to and including aforementioned full amount without any demur, reservation or recourse. Any such demand made by the Employer on the Bank shall be final, conclusive and binding, absolute and unequivocal notwithstanding any disputes raised/ pending before any Court, Tribunal, Arbitration or any Authority or any threatened litigation by the Employer of Bank..

- 3 On payment of any amount less than aforementioned full amount, as per demand of the Employer, the guarantee shall remain valid for the balance amount i.e. the aforementioned full amount less the payment made to the Employer.
- 4 The Bank shall pay the amount as demanded immediately on presentation of the demand by Employer without any reference to the contractor and without the Employer being required to show grounds or give reasons for its demand or the amount demanded.
- 5 The Bank Guarantee shall be unconditional and irrevocable.
- 6 The guarantee hereinbefore shall not be affected by any change in the constitution of the Bank or in the constitution of the Contractor.
- 7 The Bank agrees that no change, addition, modifications to the terms of the Contract Agreement or to any documents, which have been or may be made between the Employer and the Contractor, will in any way release us from the liability under this guarantee; and the Bank, hereby, waives any requirement for notice of any such change, addition or modification to the Bank.
- 8 This guarantee is valid and effective from the date of its issue, which is ***[insert date of issue]***. The guarantee and our obligations under it will expire on ***[Insert the date Sixty days after the expected end of completion period]***. All demands for payment under the guarantee must be received by us on or before that date.
- 9 The Bank agrees that the Employers right to demand payment of aforementioned full amount in one instance or demand payments in parts totaling up to the aforementioned full amount in several instances will be valid until either the aforementioned full amount is paid to the Employer or the guarantee is released by Employer before the Expiry date.
- 10 The Bank agrees that its obligation to pay any amount demanded by the Employer before the expiry of this guarantee will continue until the amount demanded has been paid in full.
- 11 The expressions Bank and Employer herein before used shall include their respective successors and assigns.
- 12 The Bank hereby undertakes not to revoke the guarantee during its currency, except with the previous consent in writing of the employer. This guarantee is subject to the Uniform Rules for Demand Guarantees, ICC Publication No. 758.
- 13 The Guarantee shall be in addition to and without prejudice to any other security Guarantee (s) of the contractor in favour of the Employer available with the Employer. The Bank, under this Guarantee, shall be deemed as Principal Debtor of the Employer.

Date

Place.....

.....

[Signature of Authorised person of Bank]

.....
 [Name in Block letters]

.....
 [Designation]

.....
 [P/Attorney] No.

.....
 Bank's Seal

[P/Attorney] No.....

Witness:

3. *Signature*
Name & Address & Seal
4. *Signature*
Name & address & Seal

Note :

- 1 *All italicized text is for guidance on how to prepare this bank guarantee and shall be deleted from the final document.*
- 2 *In case the guarantee is issued by a foreign Bank, which does not have operations in India, the said bank shall have to provide a counter-guarantee by State Bank of India.*
- 3 *In case the Contractor is a JV, the Performance Security is required to be furnished on behalf of the JV in favour of the Employer by the JV Partners in proportion of their respective percentage share specified in the JV Agreement. The percentage share of M/s **[Insert Name of the JV Partner]** in the JV is **[Fill share % in the JV]** percent. All the Bank Guarantee of JV Partners are liable to be encashed cumulatively.*

ADVANCE PAYMENT SECURITY

(On non-judicial stamp paper of appropriate value in accordance with stamp Act. The stamp paper to be in the name of Executing Bank)

From

[Name and Address of the Bank]

To

The Managing Director,
Rail Infrastructure Development Company (Karnataka) Limited,
"Samparka Soudha" , 1st Floor,
B.E.P Premises (Opp. Orion Mall),
Dr. Rajkumar Road,
Rajajinagar 1st Block,
Bangalore - 560 010

Beneficiary/Employer: Rail Infrastructure Development Company (Karnataka) Limited.

Guarantee No.: *[.....reference number of the guarantee.....]* **Dated:** *[.....]*

WHEREAS, Rail Infrastructure Development Company (Karnataka) Limited (**hereinafter called the Employer**) has entered into Contract No. *[.....reference number of the Contract.....]* dated *[.....]* for the execution of *[name of the contract]* (**hereinafter called the Contract**) with *[.....name of the Contractor.....]* (**hereinafter called the Contractor**).

WHEREAS, according to the Conditions of the Contract, an advance payment is admissible to the contractor against submission of bank guarantee(s).

At the request of the Contractor, we *[.....name of the Bank.....]* with our branch at *[.....address.....]*, having our Head Office at *[.....address.....]* (**hereinafter called the Bank**) have, at the request of *[.....Insert name of the JV partner.....]*, a JV partner on behalf of the Contractor, agreed to give the said guarantee as hereinafter contained:

1. KNOW ALL MEN by these present that I/We the undersigned *[.....Insert name(s) of authorized representative(s) of the Bank.....]*, being fully authorized to sign and incur obligations for and on behalf of the Bank, confirm that the Bank, hereby, unconditionally and irrevocably guarantees

to pay the Employer the sum of Rs.*[.....value in figure.....]* (Rupees *[.....value in words.....]* **only** (**hereinafter called the Full Amount**).

2. The Bank undertakes to immediately pay to the Employer, without any demur, reservation or recourse, any amount up to and including aforementioned full amount upon first written demand/demands from the Employer.
3. On payment of any amount less than aforementioned full amount, as per demand of the Employer, the guarantee shall remain valid for the balance amount i.e. the aforementioned full amount less the payment made to the Employer.
4. The Bank shall pay the amount so demanded without any reference to the contractor and without the Employer being required to show grounds or give reasons for its demand or the amount demanded.
5. The guarantee hereinbefore shall not be affected by any change in the constitution of the Bank, the Contractor or the Employer.
6. The Bank agrees that no change, addition, modification to the terms of the Contract Agreement or to any document, which have been or may be made between the Employer and the Contractor, will in any way release us from the liability under this guarantee; and the Bank, hereby, waives any requirement for notice of any such change, addition or modification to the Bank.
7. This guarantee is valid and effective from the date of it's issue, which is [...date of issue...]. The guarantee and our obligations under it will expire on dated[...Please refer note 4 & 5...]. All demands for payment under the guarantee must be received by us on or before that date.
8. The Bank agrees that the Employer's right to demand payment of aforementioned full amount in one instance or demand payments in parts totaling up to the aforementioned full amount in several instances will continue until either the aforementioned full amount is paid to the Employer or the guarantee validity period expires.
9. The Bank agrees that it's obligation to pay any amount demanded by the Employer before the expiry of this guarantee will continue until the amount demanded has been paid in full.
10. The expressions Bank and Employer herein before used shall include their respective successors and assigns.
11. The Bank hereby undertakes not to revoke the guarantee during its currency, except with the previous consent in writing of the employer. This guarantee is subject to the Uniform Rules for Demand Guarantees, ICC Publication No. 758.

Dated[.....]

Place[.....]

.....
(Signature of the Authorized Person of the Bank)

.....
(Name in Block Letters)

.....
(Designation)

.....
(Bank's Seal)

.....
(Authorization No.)

Witness:

1.
Signature, Name & Address

2.
Signature, Name & Address

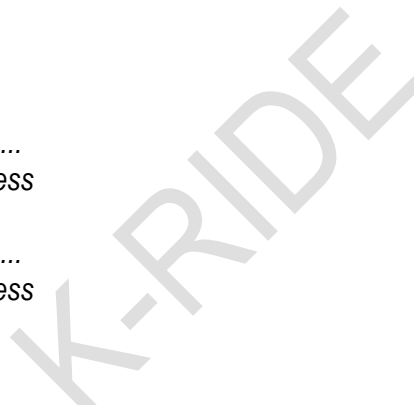

Note:

1. *All italicized text in brackets [...text...] is for guidance on how to prepare this bank guarantee and shall be deleted from the final document.*
2. *In case the guarantee is issued by a foreign Bank, the said bank shall have operations in India and should be issued by Indian operations branch of the said bank.*
3. **Mobilization Advance**

(a) For Single Entity

For each Installment of Advance, two Bank Guarantees of equal amounts (each equal to half of the first installment of advance plus 10%) shall be furnished. Each Bank Guarantee shall be valid for the stipulated completion period of the contract.

OR

(b) For JV/Consortium

For each Installment of Advance, individual JV/Consortium partner shall furnish Bank Guarantee equal to his share in the installment of Advance plus 10%. Each Bank Guarantee shall be valid for the stipulated completion period of the contract.

4. Advance against Plant and Machinery**(a) For Single Entity**

For each Installment of Advance, a Bank Guarantee equal to the installment of advance plus 10% shall be furnished. The Bank Guarantee shall be valid for the stipulated completion period of the contract.

OR

(b) For JV/Consortium

For each Installment of Advance, individual JV/Consortium partner shall furnish a Bank Guarantee equal to his share in the installment of advance plus 10%. Each Bank Guarantee shall be valid for the stipulated completion period of the contract.

K-RIDE

**INDEMNITY BOND FOR THE SAFE CUSTODY OF THE
MATERIALS SUPPLIED BY THE CONTRACTOR**

(To be executed on Non-Judicial Stamp Paper of Appropriate Value and
notarized)

THIS INDEMNITY BOND made on this _____ day of _____ 20__ by _____ (*insert the name of the Contractor and its registered address*) (hereinafter called "the Contractor") which expression shall where the context do admits or implies be deemed to include its executors, administrators and assigns, in favour of the Rail Infrastructure Development Company (Karnataka) Limited, Samparka Soudha" ,
1st Floor, B.E.P Premises (Opp. Orion Mall), Dr. Rajkumar Road, Rajajinagar 1st Block, Bangalore - 560 010 (hereinafter called "K RIDE") on the other part.

WHEREAS by an Agreement/Letter of Acceptance No. _____ dated _____ (hereinafter called "the said agreement"), the Contractor has agreed to execute the _____ (*Name of Work*) (hereinafter called "the Works") .

AND WHEREAS the Contractor has submitted to K RIDE/ the Engineer for payment on materials procured by him and brought to the site of the Works or his workshop for use in the Works.

AND WHEREAS K RIDE/ the Engineer has agreed to make payment to the Contractor the total sum of Rs. _____ (*in Figures*) [Rupees _____ (*in Words*) in Interim Payment Certificate (IPC) No. _____, the quantities and other particulars of which are detailed in this IPC for the said works signed by the Contractor on _____ for the Materials brought by the Contractor to site of the works. Brief details are also mentioned in schedule 1 appended hereto.

NOW THIS INDEMNITY BOND WITNESS that in pursuance of the said agreement and in consideration of the sum of Rs. _____ (*in Figures*) _____ (*in Words*) on or before the execution of these presents to be paid to the Contractor by K RIDE so aforesaid, the Contractor doth hereby covenant and agree with K RIDE and declare as follows: -

1. That the said sum of Rs. _____ (*In Figures*) _____ (*in Words*) to be paid by K RIDE to the Contractor as aforesaid shall be utilized by the Contractor in or towards the execution of the said works and for no other purpose whatsoever.
2. That the Materials detailed in the said IPC which have been offered to and accepted by K RIDE/ the Engineer, are absolutely the Contractor's own property and free from encumbrances of any kind and the Contractor will not make any application for or receive any further payment on the Materials which are not absolutely his own property and free from encumbrances of any kind, the Contractor indemnifies the K RIDE against all claims on any Materials in respect of which payment is to be made to him as aforesaid.
3. That the Contractor undertakes that the Materials shall be used exclusively for the performance / execution of the Contract strictly in accordance with the terms and conditions of the Contract and no part of the Materials shall be utilized for any other work or purpose whatsoever.

4. That the Contractor is obliged and shall remain absolutely responsible for the safe transit / protection and custody of the Materials against all risks whatsoever including acts of the God till the Materials are duly incorporated in the works, commissioned and are taken over by K RIDE/Railway (including surplus Materials, if required as instructed by K RIDE/ the Engineer) in accordance with the terms of the Contract. The Contractor undertakes to keep K RIDE harmless against any loss or damage that may be caused to the Materials.
5. That the said Materials shall not on any account be removed from the site of the works except with the written permission of K RIDE/ the Engineer. Further, K RIDE/ the Engineer shall always be free at all times to take possession of the materials in whatever form the materials may be in, if in its opinion, the Materials are likely to be endangered, mis-utilized or converted to uses other than those specified in the Contract, by any acts or omission or commission on the part of the Contractor or any other person or on account of any reason whatsoever and the Contractor binds himself and undertakes to comply with the directions of demand of K RIDE to return the Materials without any demur or reservation.
6. That the said materials shall, at all times, be open to inspection by K RIDE/ the Engineer or any authorized representative. In the event of the said material or any part thereof at any time being found to be in lesser quantity than for which payment has been released or the same has been stolen, destroyed or damaged or becoming deteriorated, the Contractor will forthwith replace the same or repair and make good the same as required by K RIDE/ the Engineer.
7. That making payment does not mean that Materials are of required specifications and quality or that whole of the quantity brought to site by Contractor will be used in the work. The Contractor is fully responsible for the materials to conform to required quality and specification and if at any time K RIDE/ the Engineer do not find the material satisfactory, the Contractor at his own cost would replace these. K RIDE/ the Engineer would be at liberty to recover cost of these from any dues of the Contractor. Also any Materials which are in excess of what is finally required under the contract would be the Contractor's property without any liability on K RIDE/ the Engineer who would recover the cost of this from the Contractor.
8. That this INDEMNITY BOND is irrevocable. If at any time, any loss or damage occurs to the Materials or the same or any part thereof is mis-utilized in any manner whatsoever, then the Contractor hereby agrees that the decision of K RIDE/ the Engineer as to assessment of loss or damage to the Materials shall be final and binding on the Contractor. The Contractor binds itself and undertakes to replace the lost and/or damaged Materials at its own cost and/or shall pay the amount of loss to K RIDE without any demur, reservation or protest. This is without prejudice to any other right or remedy that may be available to K RIDE/ the Engineer against the Contractor under the Contract or under this Indemnity Bond
9. That if the Contractor shall at any time make any default in the performance or observance in any respect of any of the terms and provisions of the said agreement or of those presents, the total amount of the payment shall immediately on the happening of such default be recovered by K RIDE/ the Engineer from any dues of Contractor. It is also clearly understood by the Contractor that non-observance of the obligations under this Indemnity Bond by the Contractor shall inter-alia constitute

a criminal breach of trust on the part of the Contractor for all intents and purpose including legal / penal consequences.

10. IN WITNESS WHEREOF, the Contractor has hereunto set its hand through its authorized representative, the day, month and year first above mentioned.

11. SCHEDULE 1

Particulars of the Materials	Quantity	Value of the Materials

Signed, Sealed and Delivered by the said Contractor

(Contractor's Name)

Dated:

(AUTHORISED SIGNATORY)

Place:

SEAL OF COMPANY

IN THE PRESENCE OF:

WITNESS: SIGNATURE _____

NAME: _____

ADDRESS : _____

Note:

The contractor has the option to submit the INDEMNITY BOND to cover all the items and quantities of Materials for payment or to submit INDEMNITY BOND each time the payment is to be taken or Materials advance is to be taken.

No.

Office of the.....

Date:.....

--00--00--00--

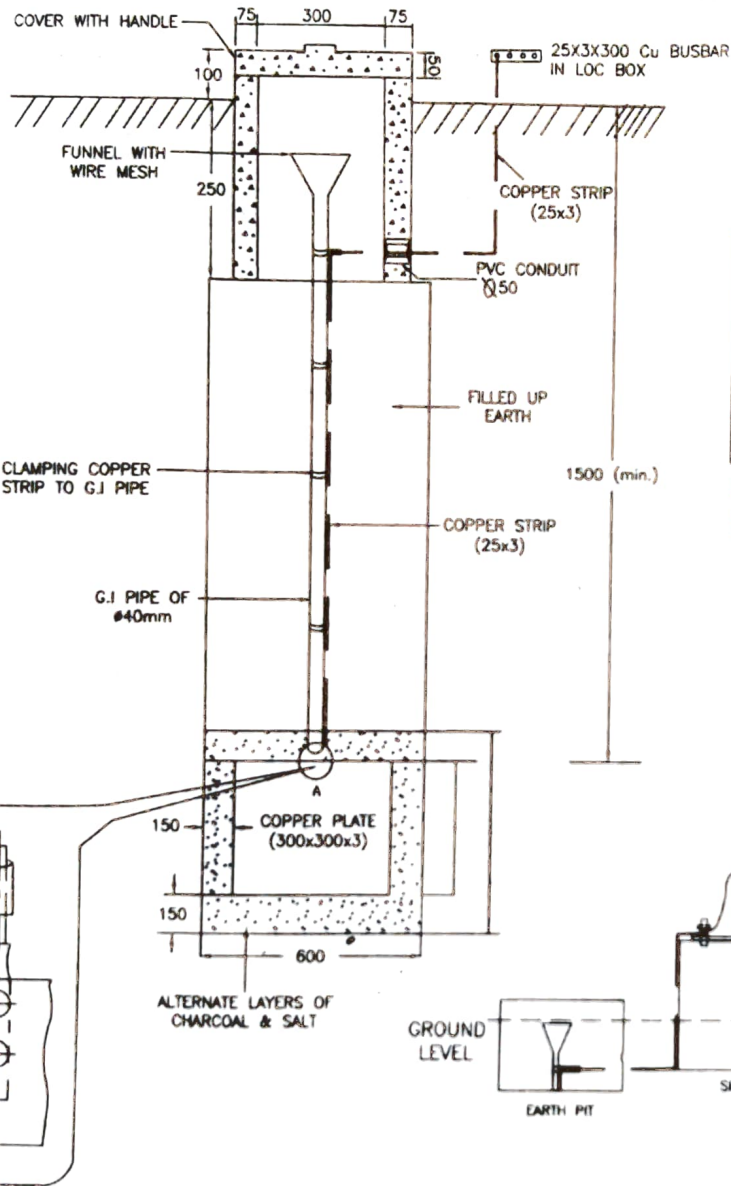

REINFORCEMENT DETAILS FOR CONCRETE CHAMBER

3D VIEW

TOP VIEW

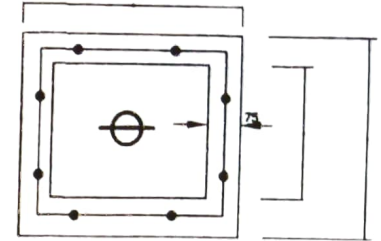
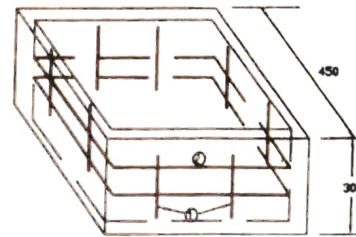

- ① VERTICAL MS RODS OF 8mm Dia., 250mm HEIGHT : 08 NUMBERS
- ② HORIZONTAL MS RINGS (350X350) OF 8mm Dia. : 02 NUMBERS

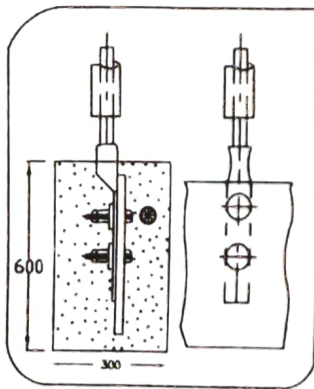

VIEW OF SECTION 'A'

NOTE:

1. All dimensions are in mm.
2. All multiple units, calling-on, shunt, route & screens shall be looped together.
3. Code of practice for earthing as per IS:3043
4. Ⓞ Copper nut & bolt (Hexagonal head) to be provided for fixing copper strip to copper plate.
5. Concrete of M25 grade 1:2:4 with maximum size of stone chips of 10mm.

	REVISION	SOUTH WESTERN RAILWAY	
	DRAWN	SIGNAL & TELECOMMUNICATION	
	SSE/DRG	C K D	TYPICAL DRAWING OF COPPER PLATE EARTHING ARRANGEMENT
	A.X.S.T.E.D		
	X.S.T.E		
	Py.CSTE/PLG		
	CSE/SWR	NOT TO SCALE	
		DRG No.	SHEET SHEETS
		SG/SWR/058	1 1

REINFORCEMENT DETAILS FOR CONCRETE CHAMBER

3D VIEW

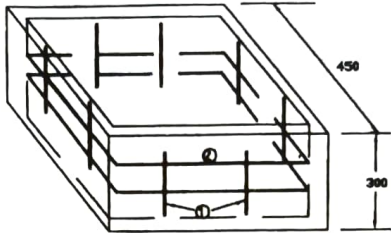

TOP VIEW

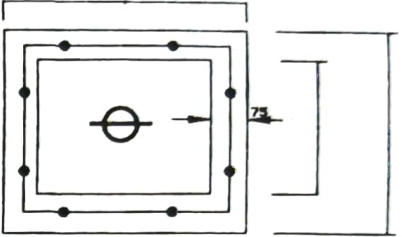

- ① VERTICAL MS RODS OF 8mm Dia., 250mm HEIGHT : 08 NUMBERS
- ② HORIZONTAL MS RINGS (350X350) OF 8mm Dia. : 02 NUMBERS

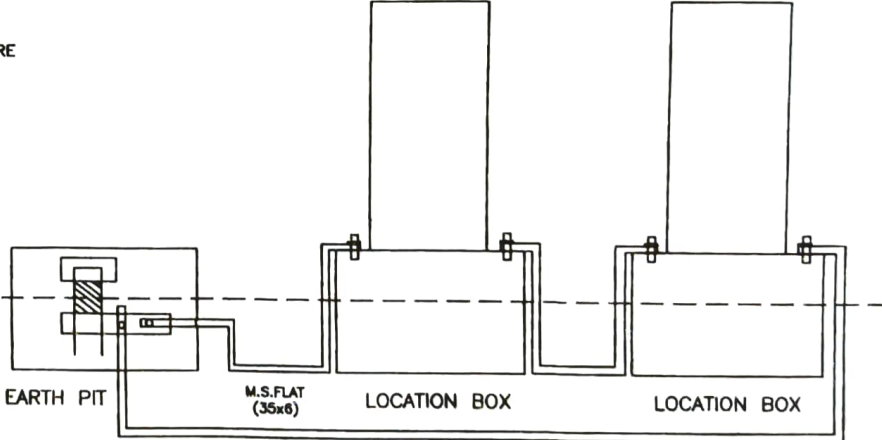
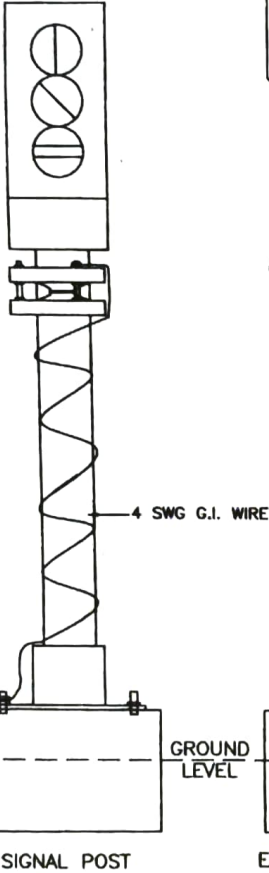
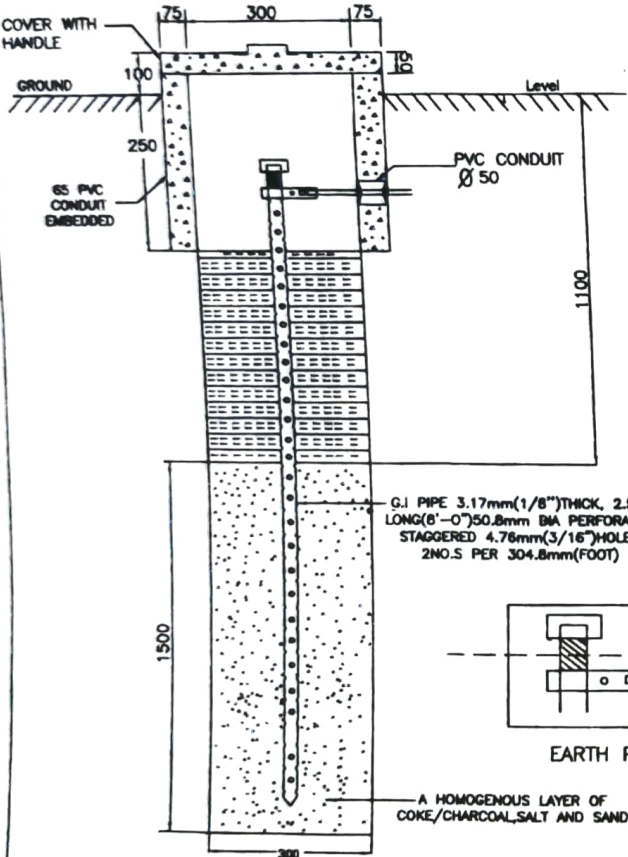

- NOTE:
1. All dimensions are in mm.
 2. All multiple units, calling-on, shunt, route & screens shall be looped together.
 3. Code of practice for earthing as per IS:3043
 4. Concrete of M25 grade 1:2:4 with maximum size of stone chips of 10mm.

	REVISION	SOUTH WESTERN RAILWAY	
R.A.N.RAO	DRAWN	SIGNAL & TELECOMMUNICATION	
ED	SSE/DRG	C K D	TYPICAL DRAWING OF CONVENTIONAL EARTHING ARRANGEMENT
M. Nagaraj	A.X.S.T.E/D		
9/4/19	X.S.T.E		
S. NAGESWARA RAO	DRY.CSTE/PLG	NOT TO SCALE	
B.S. ISAIJAH	CSE/SWR	DRG.No.	SHEET SHEETS
		SG/SWR/057	1 1

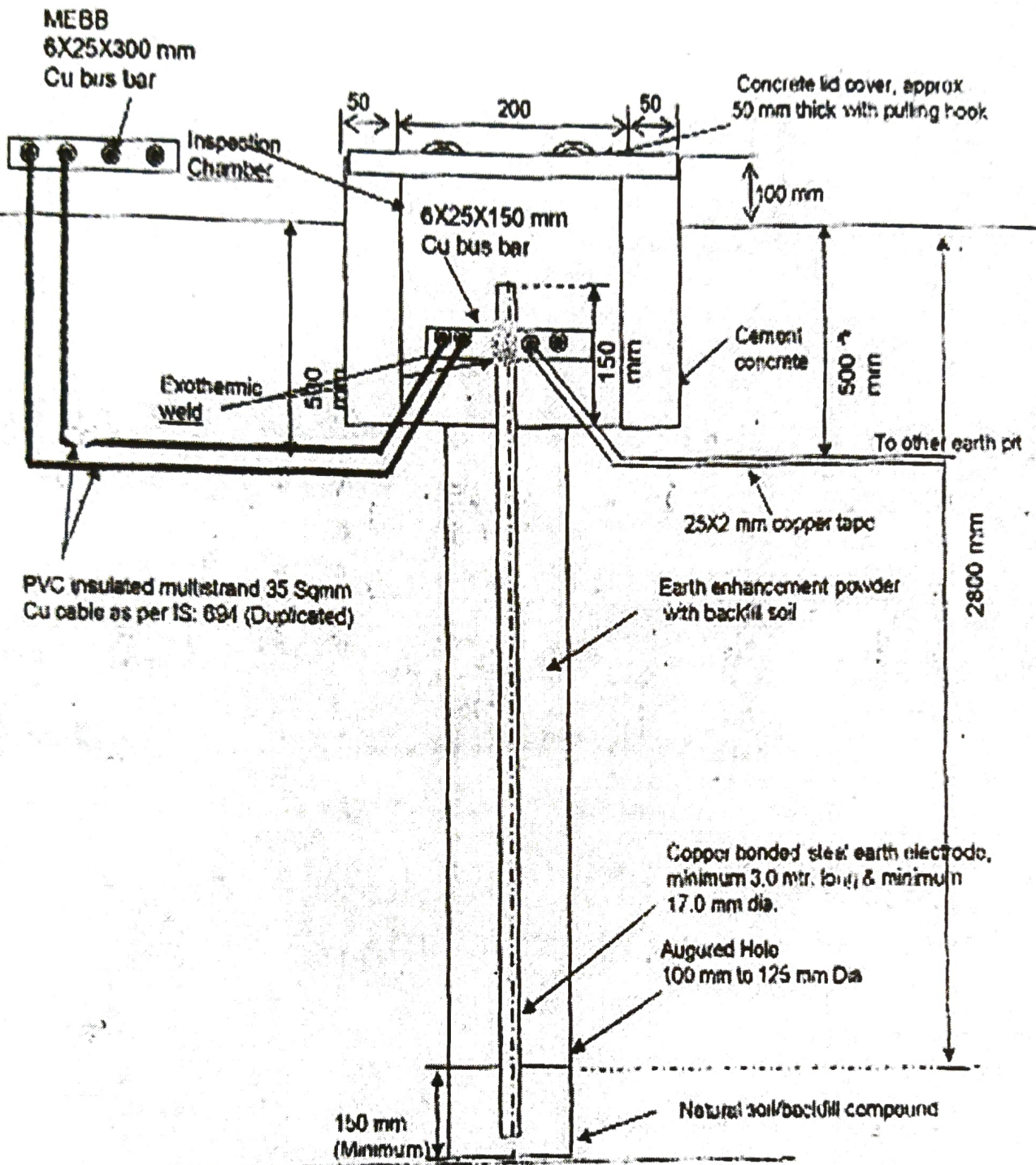

			RDSO	
			Typical installation of earth for S&T Installations	
<i>JE/SE/slg</i>	<i>AD/SE/slg</i>	<i>For DG/Slg</i>	Org. No. SDQ / RDSO/ E&B/001	Sheet No: 1 of 1
			Date: 19.09.08	

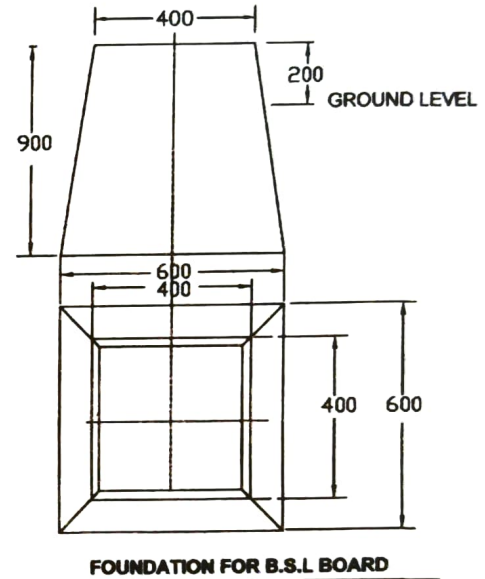
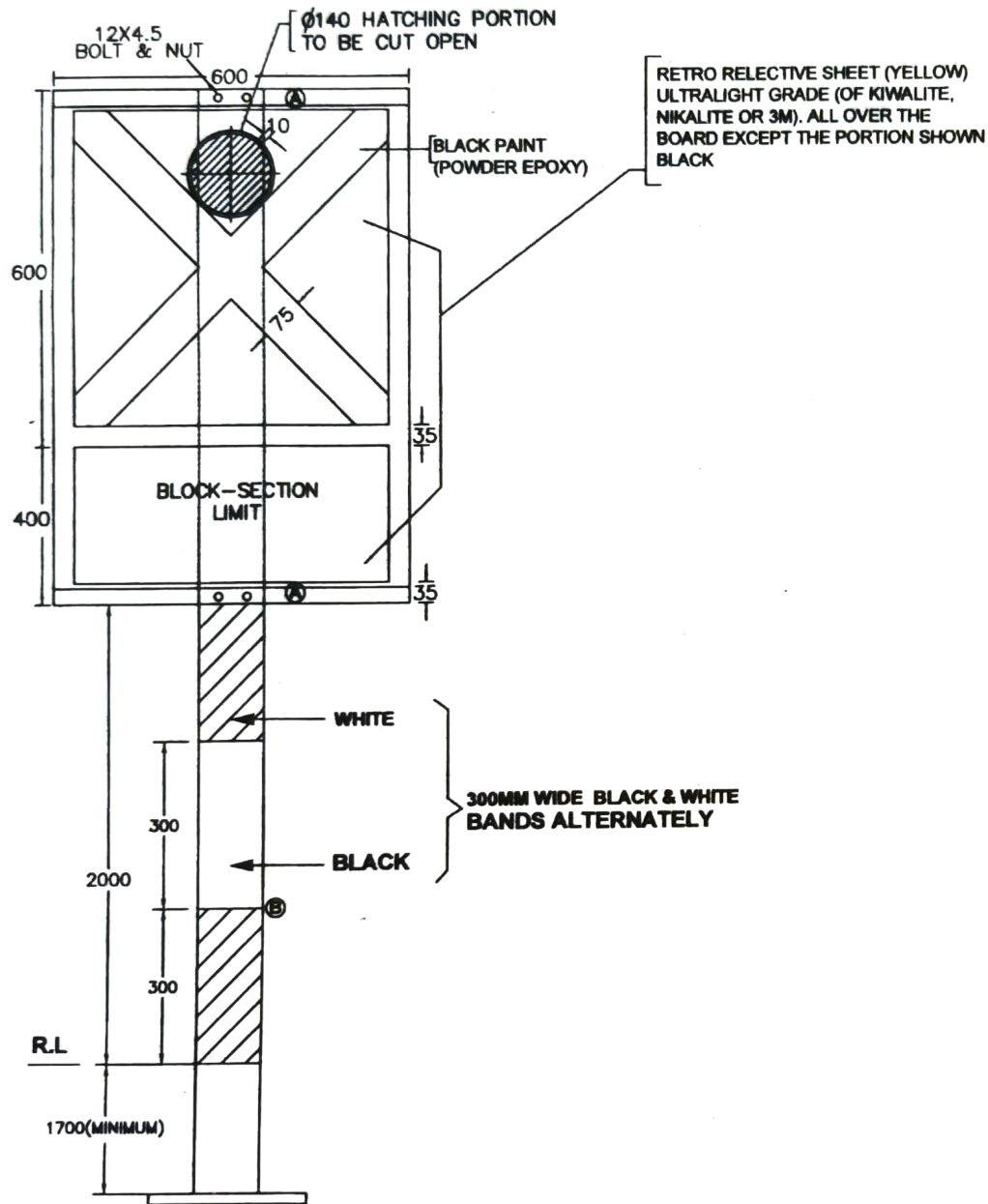

NOTE:
 ALL DIMENTIONS ARE IN MM.
 THICKNESS OF THE BOARD 3MM
 TO BE FILLED WITH CEMENT MORTAR.

- Ⓐ M.S.FLAT 5X25 WELDED TO THE BOARD
- Ⓑ M.S.ANGLE 75X75X10
- CONCRETE 1: 3: 6

REVISION		SOUTH WESTERN RAILWAY	
R.A.N.RAO	DRAWN	SIGNAL & TELECOMMUNICATION	
<i>[Signature]</i>	SSE/DRG	C K D	TYPICAL DRAWING OF BLOCK SECTION LIMIT BOARD
<i>[Signature]</i> 07.02.19	A.X.S.T.E/D		
<i>[Signature]</i> 9.4.19	X.S.T.E		
<i>[Signature]</i>	Dy.CSTE/PLG	NOT TO SCALE	
S.NAGESWARA RAO	CSE/SWR	DRG.No.SG/SWR/051	
		SHEET	SHEETS
		1	1

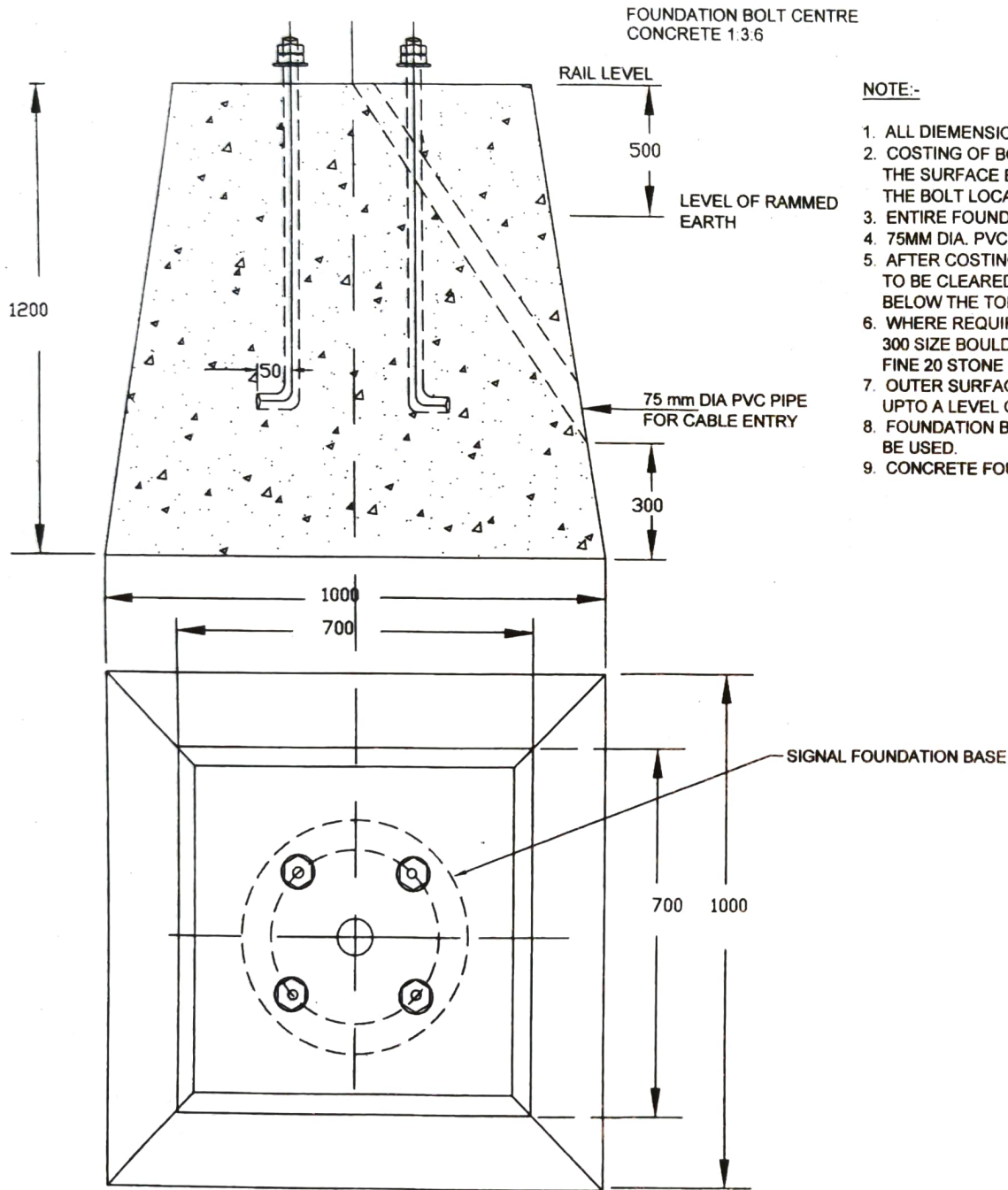

NOTE:-

1. ALL DIMENSIONS ARE IN MM.
2. COSTING OF BOLTS TO BE DONE IN THE CONCRETE BASE DULY TAKING HE MEASUREMENTS OF THE SURFACE BASE AND CIRCLE ALSO ALIGNING THE FOUR HOLES OF THE SURFACE BASE WITH THE BOLT LOCATION 1, 2, 3 & 4 BY PROVIDING TEMPLATE.
3. ENTIRE FOUNDATION SHOULD BE CAST IN ONE STRETCH AND WITH BOLT ONLY.
4. 75MM DIA. PVC PIPE TO BE EMBEDDED DURING CASTING ITSELF (AND NOT LATER ON).
5. AFTER COSTING OF BASE AND CURING OF THE SAME IS OVER THE FOUR SIDES OF THE BASE TO BE CLEARED OF ALL LEFT OVER CONCRETE AND SIDES DULY RAMMED WITH EARTH UPTO 500 BELOW THE TOP OF THE BASE.
6. WHERE REQUIRED PITCHING ON THE RELEVANT SIDES OF THE RAMMED SURFACE WITH 225 TO 300 SIZE BOULDERS SHALL BE DONE AND FILLING THE CREVICES WITH 10:6:12 CONCRETE WITH FINE 20 STONE CHIPS. PITCHING WILL BE TO THE FULL HEIGHT OF THE RAMMED EARTH.
7. OUTER SURFACE SHOULD BE PLASTERED FROM TOP OF FOUNDATION WITH 1:2 CEMENT AND SAND UPTO A LEVEL OF 500MM.
8. FOUNDATION BOLT OF SIZE 30MM DIA 750MM LONG WITH 2 FLAT WASHERS & 2 NUTS ARE TO BE USED.
9. CONCRETE FOUNDATION WITH RATIO 1:3:6.

	REVISION	SOUTH WESTERN RAILWAY	
R.A.N.RAO	DRAWN	SIGNAL & TELECOMMUNICATION	
<i>Gov</i>	SSE/DRG	C K D	TYPICAL DRAWING OF ROAD WARNING SIGNAL FOUNDATION
<i>Mys</i> 09.04.19	A.X.S.T.E/D		
<i>SH</i> 9.4.19	X.S.T.E		
<i>JV</i> 10/4/19 (S.NAGESWARA RAO)	Dy.CSTE/PLG	NOT TO SCALE	
<i>B.S.</i> 10/4/19 (B.S.ISAIAH)	CSE/SWR	DRG.No. SG/SWR/054	SHEET SHEETS 1 1

FOUNDATION BOLT CENTRE
CONCRETE 1:3:6

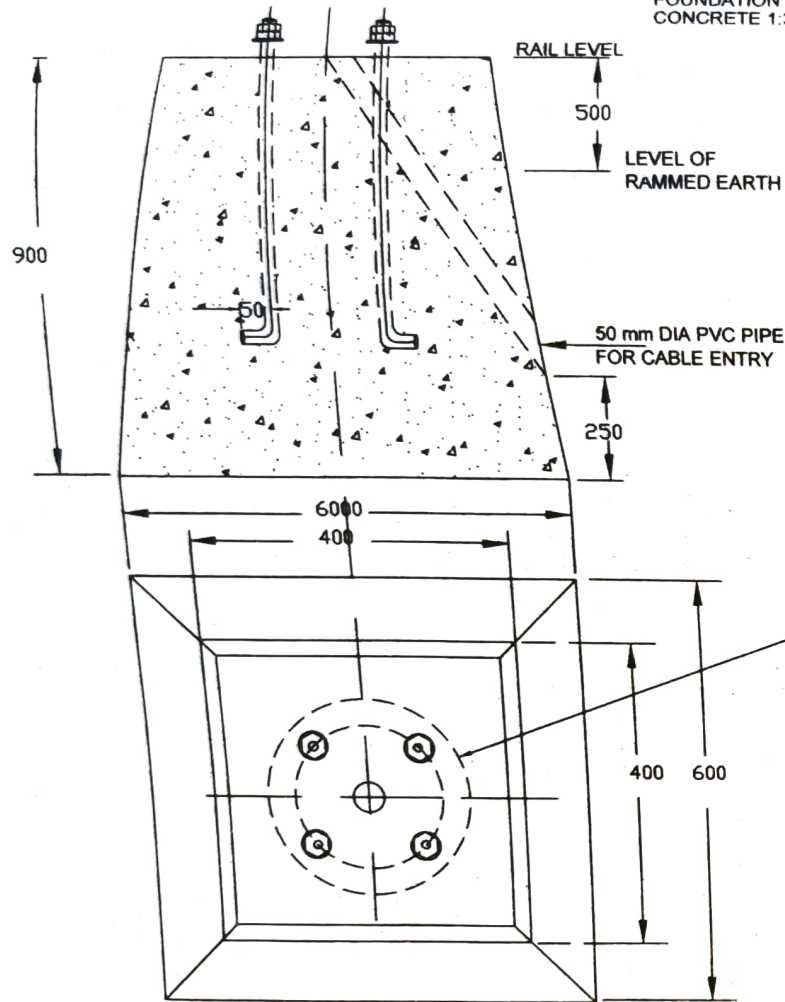

NOTE:-

1. ALL DIMENSIONS ARE IN MM.
2. COSTING OF BOLTS TO BE DONE IN THE CONCRETE BASE DULY TAKING HE MEASUREMENTS OF THE SURFACE BASE AND CIRCLE ALSO ALIGNING THE FOUR HOLES OF THE SURFACE BASE WITH THE BOLT LOCATION 1, 2, 3 & 4 BY PROVIDING TEMPLATE.
3. ENTIRE FOUNDATIONSHOULD BE CAST IN ONE STRETCH AND WITH BOLT ONLY.
4. 50MM DIA. PVC PIPE TO BE EMBEDDED DURING CASTING ITSELF (AND NOT LATER ON).
5. AFTER COSTING OF BASE AND CURING OF THE SAME IS OVER THE FOUR SIDES OF THE BASE TO BE CLEARED OF ALL LEFT OVER CONCRETE AND SIDES DULY RAMMED WITH EARTH UPTO 500 BELOW THE TOP OF THE BASE.
6. WHERE REQUIRED PITCHING ON THE RELEVANT SIDES OF THE RAMMED SURFACE WITH 225 TO 300 SIZE BOULDERS SHALL BE DONE AND FILLING THE CREVICES WITH 10:6:12 CONCRETE WITH FINE 20 STONE CHIPS. PITCHING WILL BE TO THE FULL HEIGHT OF THE RAMMED EARTH.
7. OUTER SURFACE SHOULD BE PLASTERED FROM TOP OF FOUNDATION WITH 1:2 CEMENT AND SAND UPTO A LEVEL OF 500MM.
8. FOUNDATION BOLT OF SIZE 22MM DIA 450MM LONG WITH 2 FLAT WASHERS & 2 NUTS ARE TO BE USED.
9. CONCRETE FOUNDATION WITH RATIO 1:3:6.
10. SAME DRAWING CAN BE ADOPTED FOR GWB, BSLB, CALLING-ON LEGEND BOARD OR ANY OTHER BOARDS OF SPECIFIED IN SIP.

	REVISION	SOUTH WESTERN RAILWAY	
R.A.N.RAO	DRAWN	SIGNAL & TELECOMMUNICATION	
<i>[Signature]</i>	SSE/DRG	C K D	TYPICAL DRAWING OF SHUNT SIGNAL FOUNDATION
<i>[Signature]</i> 09.04.19	A.X.S.T.E/D		
<i>[Signature]</i> 9.4.19	X.S.T.E		
<i>[Signature]</i> (S.NAGESWARA RAO)	Dy.CSTE/PLG	NOT TO SCALE	
<i>[Signature]</i> (B.S.ISAIAH)	CSE/SWR	DRG.No. SG/SWR/053	SHEET SHEETS 1 1

FOUNDATION BOLT CENTRE
CONCRETE 1:3:6

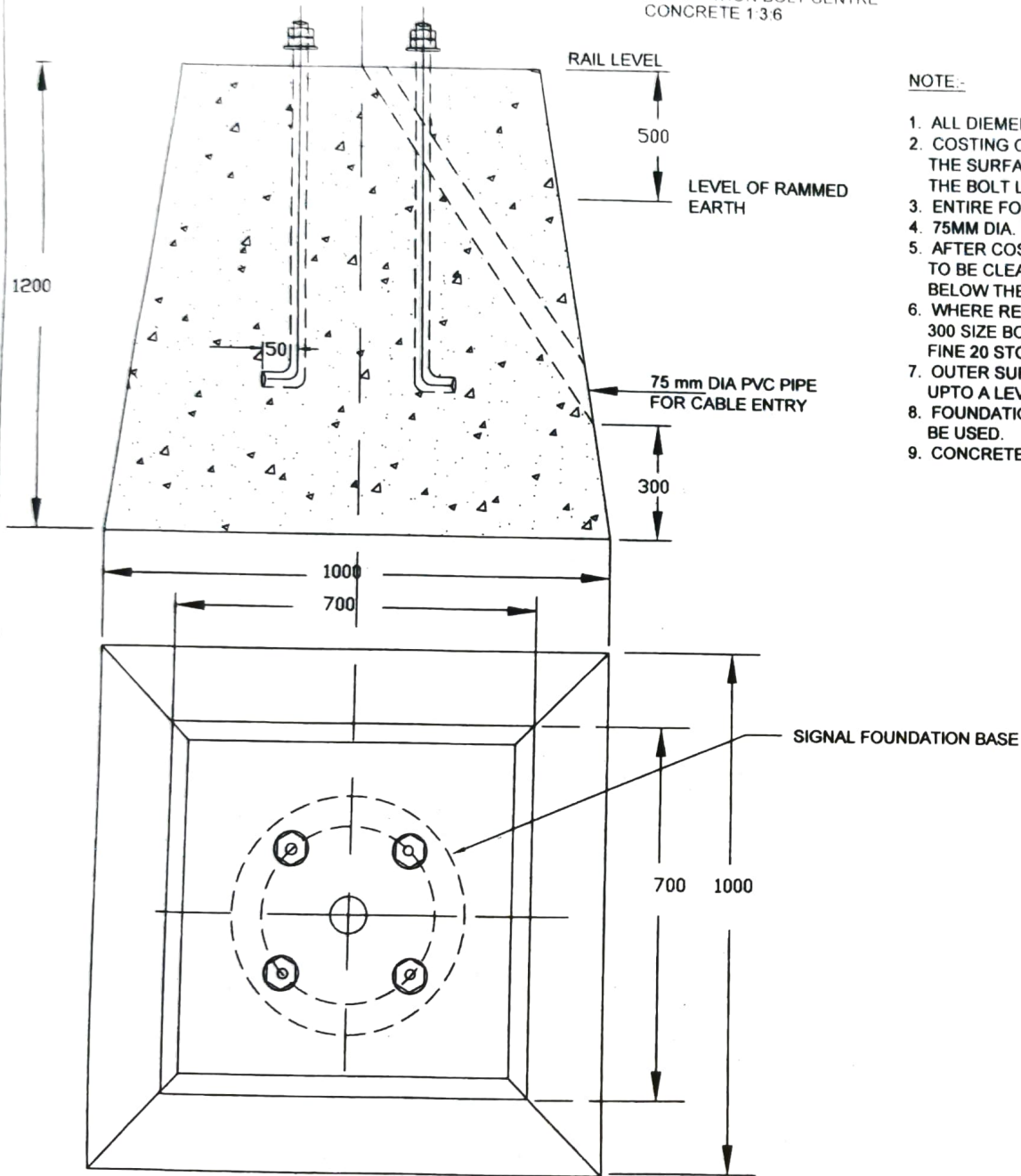

NOTE:-

1. ALL DIEMENSIONS ARE IN MM.
2. COSTING OF BOLTS TO BE DONE IN THE CONCRETE BASE DULY TAKING HE MEASUREMENTS OF THE SURFACE BASE AND CIRCLE ALSO ALIGNING THE FOUR HOLES OF THE SURFACE BASE WITH THE BOLT LOCATION 1, 2, 3 & 4 BY PROVIDING TEMPLATE.
3. ENTIRE FOUNDATION SHOULD BE CAST IN ONE STRETCH AND WITH BOLT ONLY
4. 75MM DIA. PVC PIPE TO BE EMBEDDED DURING CASTING ITSELF (AND NOT LATER ON).
5. AFTER COSTING OF BASE AND CURING OF THE SAME IS OVER THE FOUR SIDES OF THE BASE TO BE CLEARED OF ALL LEFT OVER CONCRETE AND SIDES DULY RAMMED WITH EARTH UPTO 500 BELOW THE TOP OF THE BASE.
6. WHERE REQUIRED PITCHING ON THE RELEVANT SIDES OF THE RAMMED SURFACE WITH 225 TO 300 SIZE BOULDERS SHALL BE DONE AND FILLING THE CREVICES WITH 10:6:12 CONCRETE WITH FINE 20 STONE CHIPS. PITCHING WILL BE TO THE FULL HEIGHT OF THE RAMMED EARTH.
7. OUTER SURFACE SHOULD BE PLASTERED FROM TOP OF FOUNDATION WITH 1:2 CEMENT AND SAND UPTO A LEVEL OF 500MM.
8. FOUNDATION BOLT OF SIZE 30MM DIA 750MM LONG WITH 2 FLAT WASHERS & 2 NUTS ARE TO BE USED.
9. CONCRETE FOUNDATION WITH RATIO 1:3:6.

REVISION		SOUTH WESTERN RAILWAY	
—	—	SIGNAL & TELECOMMUNICATION	
R.A.N.RAO	DRAWN	C K D	TYPICAL DRAWING OF MAIN SIGNAL POST FOUNDATION
<i>602</i>	SSE/DRG		
<i>09.04.19</i>	A.X.S.T.E/D		
<i>09.04.19</i>	X.S.T.E		
<i>2/10/19</i> (S.NAGESWARA RAO)	Dy.CSTE/PLG	NOT TO SCALE	
<i>10/9/19</i> (B.S.ISAIAH)	CSE/SWR	DRG.No. SG/SWR/052	SHEET SHEETS 1 1

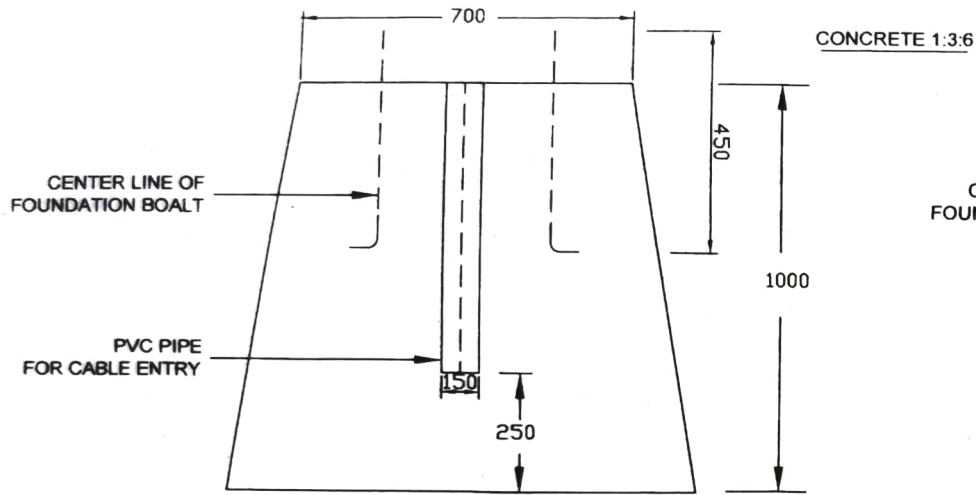

SECTION VIEW

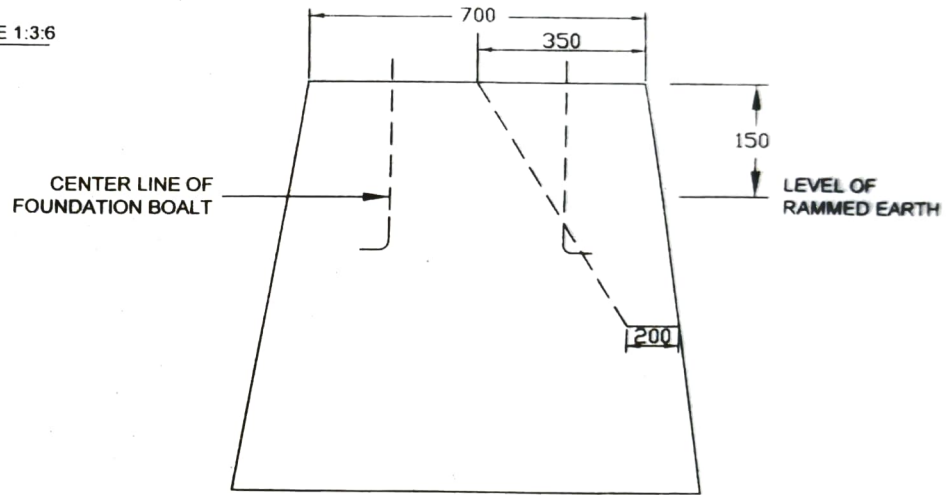

SIDE VIEW

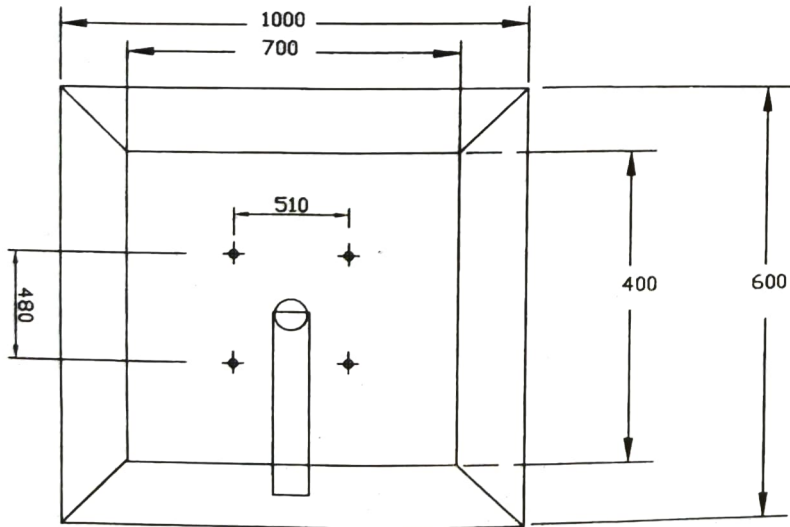

PLAN

NOTE:-

1. ALL DIEMENSIONS ARE IN MM.
2. CONCRETE FOUNDATION WITH MIXTURE OF CEMENT, SAND AND JELLY CHIPS, SIZE:20, WITH RATIO 1:3:6.
3. OUTER SURFACE SHOULD BE PLASTERED WITH 1:4 CEMENT AND SAND.
4. ON ALL SIDES OF THE EARTH SHOULD BE RAMMED INTO THE LEVEL AS SHOWN IN THE SKETCH.
5. FOUNDATION BOLT OF SIZE 22MM DIA., 450MM LONG WITH 2 FLAT WASHERS & ONE NUT IS TO BE USED.

	REVISION	SOUTH WESTERN RAILWAY	
R.A.N.RAO	DRAWN	SIGNAL & TELECOMMUNICATION	
60	SSE/DRG	C K D	TYPICAL DRAWING OF APPARATUS CASE (HALF/QUARTER SIZE) FOUNDATION
09.04.19	A.X.S.T.E/D		
09.04.19	X.S.T.E		
S.NAGESWARA RAO	Py.CSTE/PLG	NOT TO SCALE	
(B.S.ISAIAH)	CSE/SWR	DRG.No. SG/SWR/056	SHEET SHEETS
		1	1

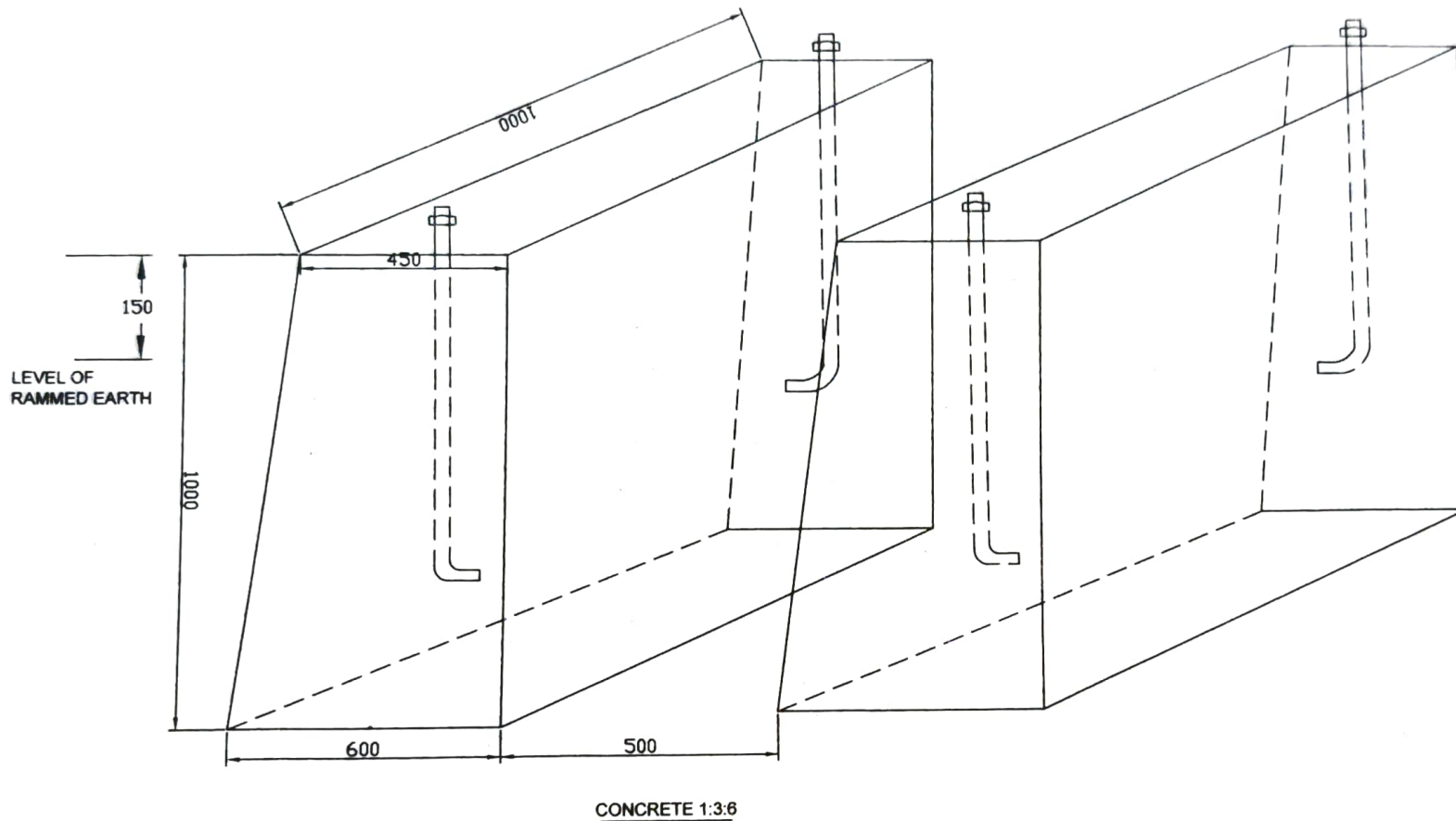

NOTE:-

1. ALL DIMENSIONS ARE IN MM.
2. CONCRETE FOUNDATION WITH MIXTURE OF CEMENT, SAND AND JELLY CHIPS, SIZE:20, WITH RATIO 1:3:6.
3. OUTER SURFACE SHOULD BE PLASTERED WITH 1:4 CEMENT AND SAND.
4. ON ALL SIDES OF THE EARTH SHOULD BE RAMMED INTO THE LEVEL AS SHOWN IN THE SKETCH.
5. FOUNDATION BOLT OF SIZE 22MM DIA., 450MM LONG WITH 2 FLAT WASHERS & ONE NUT IS TO BE USED.

	REVISION	SOUTH WESTERN RAILWAY	
R.A.N.RAO	DRAWN	SIGNAL & TELECOMMUNICATION	
	SSE/DRG	C K D	TYPICAL DRAWING OF APPARATUS CASE (FULL SIZE) FOUNDATION
<i>[Signature]</i> 09.04.19	A.X.S.T.E/D		
<i>[Signature]</i> 9.4.19	X.S.T.E		
<i>[Signature]</i> (S.NAGESWARA RAO)	Dy.CSTE/PLG		
<i>[Signature]</i> (B.S.ISAIAH)	CSE/SWR	NOT TO SCALE	
	DRG.No. SG/SWR/055	SHEET	SHEETS
		1	1

REINFORCEMENT DETAILS FOR RCC CABLE MARKER

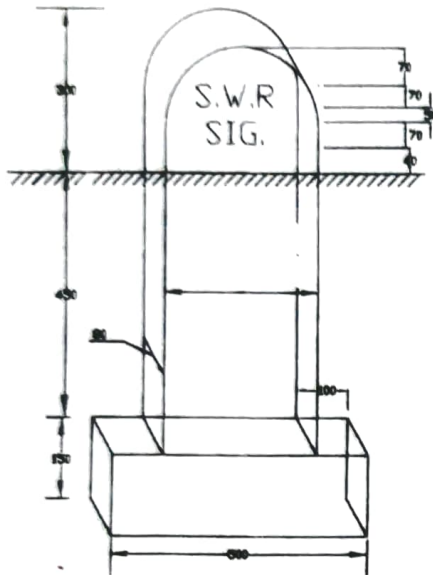

8mm DIA M.S. ROD (1) No. OF LENGTH 1850mm APPROXIMATELY BENT AT THE TOP AS SHOWN IN THE SKECH.

4mm DIA M.S. TIE ROD (2) Nos. OF LENGTH 250mm.

6mm DIA M.S. ROD (3) No. OF LENGTH 800mm APPROXIMATELY

6mm DIA M.S. ROD OF LENGTH 450mm

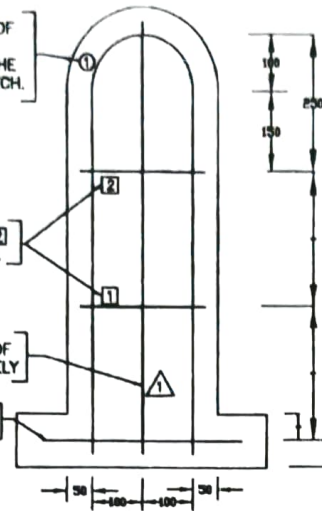

3D VIEW

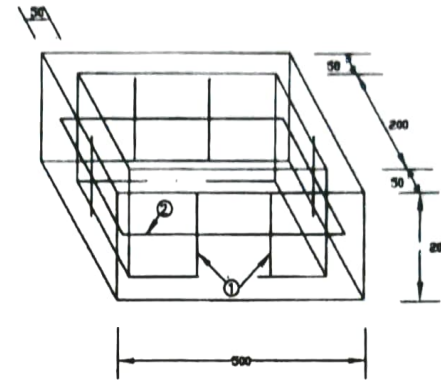

TOP VIEW

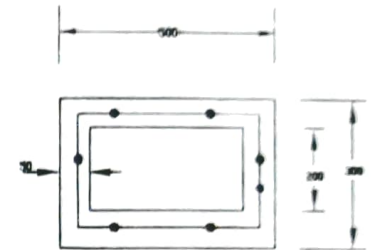

- ① VERTICAL MS RODS OF 8mm Dia., 150mm HEIGHT : 08 NUMBERS
- ② HORIZONTAL MS RINGS (350X350) OF 8mm Dia. : 01 NUMBERS

CONCRETE SKIRTING FOR PLACING ON CABLE MARKER

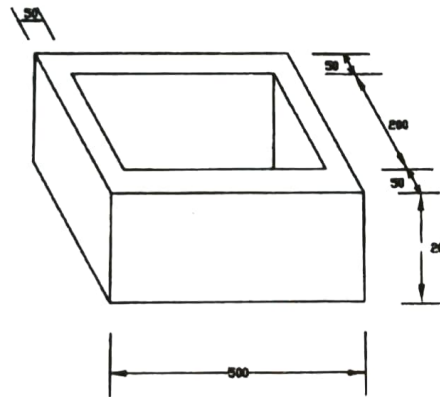
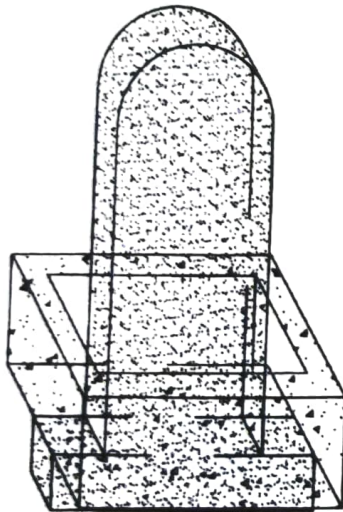

NOTE:-

1. ALL DIEMENSIONS ARE IN MM.
2. CABLE MARKER SHALL BE ENGRAVED WITH SWR SIG/SWR QUAD/SWR OFC AS THE CASE MAY BE OF 2.8" (70MM) HEIGHT.
3. CABLE MARKERS SHALL BE PAINTED IN RED COLOR CEMENT PAINT FOR SIGNALLING CABLES AND IN ORANGE COLOR CEMENT PAINT FOR TELECOM CABLES. ENGRAVED LETTERS SHALL BE PAINTED IN WHITE COLOR CEMENT PAINT.
4. AFTER PLACING PRECAST RCC SKIRTING ON THE PRECAST RCC MARKER AS SHOWN, GAP BETWEEN THE CABLE MARKER AND SKIRTING SHALL BE FILLED WITH RICH MORTAR.
5. THE PROPORTION FOR CEMENT, SAND & JELLY SHALL BE 1:2:4 WITH 6mm TO 10mm GRANITE METAL.
6. FOR MILD STEEL THE SPECIFICATION IS IS:432.
7. CABLE MARKERS SHALL BE PLACED AT AN INTERVAL OF 20M WITH IN STATION SECTION AND 50M IN BLOCK SECTION.

	REVISION	SOUTH WESTERN RAILWAY	
R.A.N.RAO	DRAWN	SIGNAL & TELECOMMUNICATION	
	SSE/DRG	C K D	TYPICAL DRAWING FOR RCC CABLE MARKER
	A.X.S.T.E/D		
	X.S.T.E		
	Dy. CSTE/PLG		
	(S.NAGESWARA RAO)		
	CSE/SWR	NOT TO SCALE	
	(B.S.ISAIAH)	DRG.No.	SHEET SHEETS
		SG/SWR/067	1 1

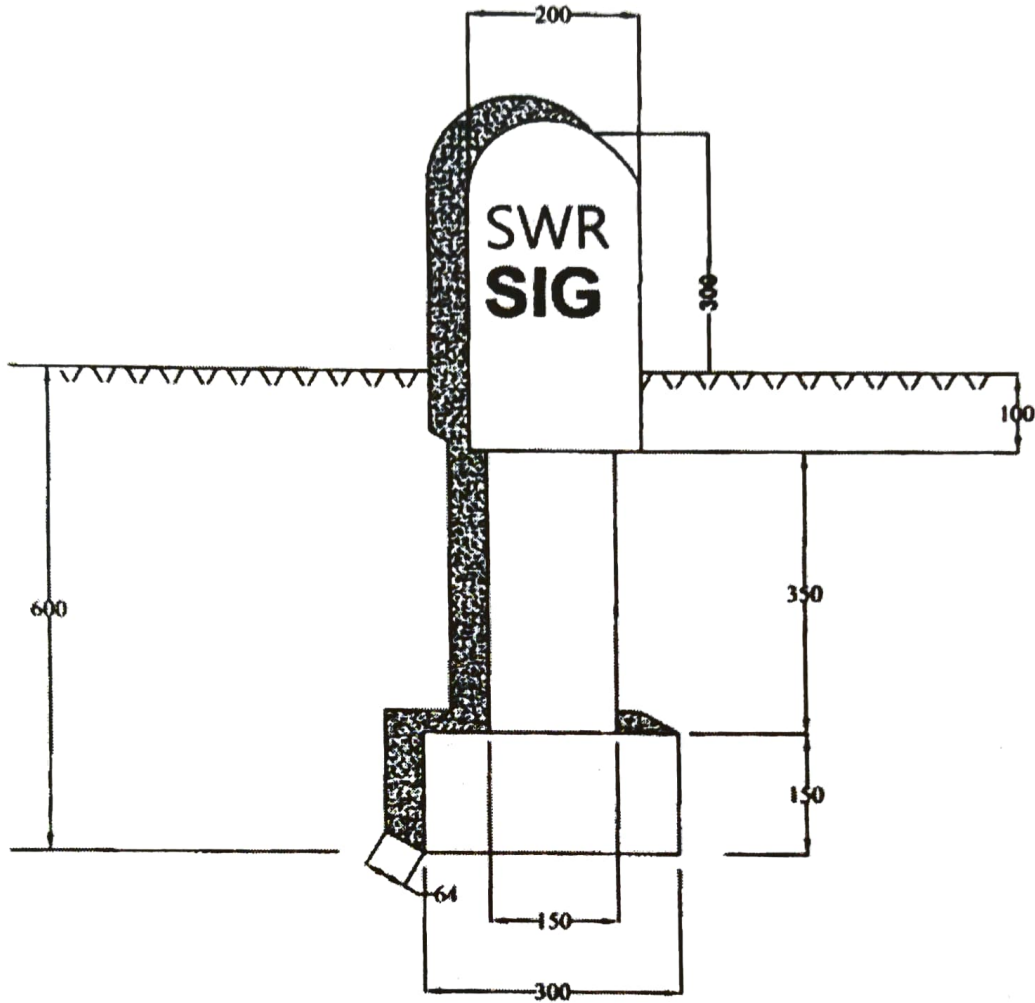

NOTE:-

1. ALL DIMENTIONS ARE IN MILLIMETER
2. PAINTED WHITE LETTERS ON RED BACKGROUND.
3. FOUNDATION CONCRETE OF 300 mm FROM THE BASE OF THE MARKER SHALL BE DONE AT SITE AT ALL PLACES WITH MIX 1:3:5.
4. COMPONENT CONCRETE SHALL BE OF M25 MIX AND WIRE MESH OF 1.5MM THICKNESS SHALL BE USED.
5. THE ENGRAVING OF "RLY" & "SIG" SHALL BE DONE ON BOTH SIDES OF THE MARKER.

CHECKED BY	JE/SE/SSE	CONCRETE CABLE MARKER	SDO/CABLE LAYING/020
APPROVED BY	ADE	R.D.S.O.	DATE :- 31-10-2011

NOT TO SCALE

YESVANTPUR Jn.


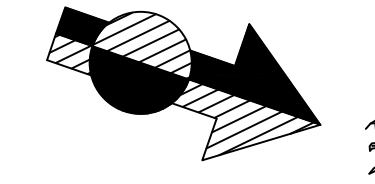

TENTATIVE PLAN

Note : Shown in Dotted is non Interlocked area